

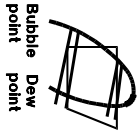

Quick Selection

*Automatic Controls, Compressors
and Condensing units*

Refrigerant conversion table



Refrigerant	Property	Temperature [°C]	Temperature [°F]	Pressure [bar]	Pressure [psia]	Pressure [psig]	Pressure [in Hg]
R407C	Dew	-80 to 80	-120 to 140	0.2 to 100	0.3 to 140	0.2 to 99	0.2 to 30
	Bubble	-80 to 80	-120 to 140	0.2 to 100	0.3 to 140	0.2 to 99	0.2 to 30
R134a	Dew	-50 to 80	-60 to 140	0.2 to 100	0.3 to 140	0.2 to 99	0.2 to 30
	Bubble	-50 to 80	-60 to 140	0.2 to 100	0.3 to 140	0.2 to 99	0.2 to 30
R717	Dew	-70 to 80	-100 to 140	0.2 to 100	0.3 to 140	0.2 to 99	0.2 to 30
	Bubble	-70 to 80	-100 to 140	0.2 to 100	0.3 to 140	0.2 to 99	0.2 to 30
R410A	Dew	-100 to 80	-150 to 140	0.2 to 100	0.3 to 140	0.2 to 99	0.2 to 30
	Bubble	-100 to 80	-150 to 140	0.2 to 100	0.3 to 140	0.2 to 99	0.2 to 30
R507	Dew	-100 to 80	-150 to 140	0.2 to 100	0.3 to 140	0.2 to 99	0.2 to 30
	Bubble	-100 to 80	-150 to 140	0.2 to 100	0.3 to 140	0.2 to 99	0.2 to 30
R404A	Dew	-90 to 80	-130 to 140	0.2 to 100	0.3 to 140	0.2 to 99	0.2 to 30
	Bubble	-90 to 80	-130 to 140	0.2 to 100	0.3 to 140	0.2 to 99	0.2 to 30
R22	Dew	-90 to 80	-130 to 140	0.2 to 100	0.3 to 140	0.2 to 99	0.2 to 30
	Bubble	-90 to 80	-130 to 140	0.2 to 100	0.3 to 140	0.2 to 99	0.2 to 30

Table of contents

1. Expansion valves		7. Line components – Industrial	
Thermostatic expansion valves		Filters FIA, FIA-SS 100	Liquid level glasses LLG 102
Thermostatic expansion valves T2, TE2 6		8. Gas Detector	
Thermostatic expansion valves TE5-55 10		Gas detectors GD 104	
Thermostatic expansion valves TUA, TUAE and TCAE 14		9. Electronic controls	
Thermostatic expansion valves PHT 20		Refrigeration controllers EKC 315A 106 EKC 202 108
Electronically operated		Controller for appliance control AK-CC 550 110	Temperature controller EKC 102 112
Expansion valves AKV 24		Universal refrigeration controller AK-CC 210 114	System manager AK-SM 350 116
Electrical expansion valves ETS 28		Media temperature control EKC 361 118	Controller interface EKC 366 120
2. Solenoid valves and coils		Condenser fan speed controls XGE/RGE 122	Capacity controllers..... EKC 331T 124
Solenoid valves and coils EVR 30	 AK-PC 530 126	
Solenoid valves EVRA and EVRAT 32		10. Sensors and transmitters	
4-Way Reversing valves VHV and STF 34		Sensors and transmitters 128	
3. Pressure controls and thermostats		11. Compressors range	
Pressure controls and thermostats KP 36		Compressors 131	Direct current reciprocating compressors 133
Cartridge pressure controls ACB 38		Reciprocating Compressors 145	Scroll compressors 153
Thermostat UT 40		12. Condensing units range	
Pressure controls and thermostats RT 42		OPTYMA™ condensing units 167	OPTYMA PLUS™ condensing units 185
4. Pressure regulators			
Pressure regulators KVP 46			
Pressure regulators KVR and NRD 48			
Pressure regulators KVL 50			
Pressure regulators KVD 52			
Pressure regulators KVC 54			
Capacity regulator CPCE 56			
Motor valves ICM 20-65 58			
Pilot controlled servo valves ICS 25-65 62			
5. Water valves			
Pressure controlled water valve WVFX 68			
Thermostatic controlled water valves AVTA 70			
6. Line components – Commercial			
Ball valves GBC 72			
Check valves NRV and NRVH 74			
Oil separator OUB 76			
Heat exchanger HE 78			
Sight glasses SGN/H, SGR, SGRN/H 80			
Liquid line filter driers DML 82			
Filter driers DCR 84			
Bi-flow filter driers DMB 88			
Combi filter driers DMC 90			
Burn-out filter drier DAS 92			
Stop valves SVA 94			
Regulating valves REG and REG-SS 98			

Table of contents – Type

ACB	38
AK-CC 210	114
AK-CC 550	110
AK-PC 530	125
AK-SM 350	116
AKV	24
AVTA	70
Compressors	131
CPCE	56
DAS	92
DCR	84
Direct current reciprocating compressors	133
DMB	88
DMC	90
DML	82
EKC 102	112
EKC 202	108
EKC 315A	106
EKC 331T	124
EKC 361	118
EKC 366	129
ETS	28
EVR	30
EVRA and EVRAT	32
FIA, FIA-SS	100
GBC	72
GD	105
HE	78
ICM 20-65	58
ICS 25-65	62
KP	36
KVC	54
KVD	52
KVL	50
KVP	46
KVR and NRD	48
LLG	102
NRV and NRVH	74
OPTYMA PLUS™ condensing units	185
OPTYMA™ condensing units	167
OUB	76
PHT	20
Reciprocating Compressors	145
REG and REG-SS	98
RT	42
Scroll compressors	153
Sensors and transmitters	128
SGN/H, SGR, SGRN/H	80
SVA	94
T2, TE2	6
TE5-55	10
TUA, TUAE and TCAE	14
UT	40
VHV and STF	34
WVFX	68
XGE/RGE	122



T2 / TE2: reliable and easy to use

Thermostatic expansion valves regulate the injection of liquid refrigerant into evaporators. Injection is controlled by the refrigerant superheat. Therefore the valves are especially suitable for liquid injection in "dry" evaporators where the superheat at the evaporator outlet is proportional to the evaporator load.

Features

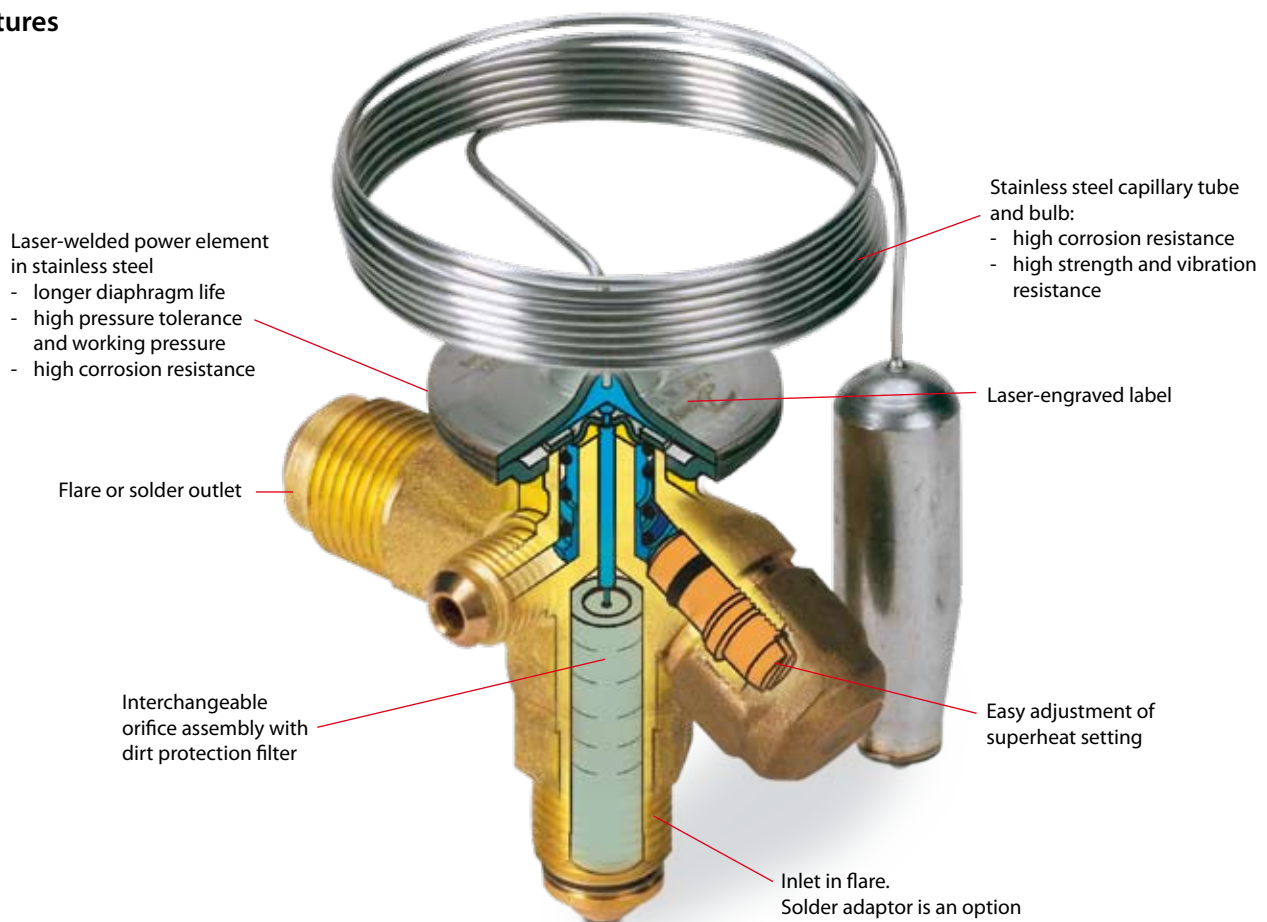

Applications	Advantages	Facts
<ul style="list-style-type: none"> · Traditional refrigeration · Heat pump systems · Air conditioning units · Liquid coolers · Ice cube machines · Transport refrigeration 	<ul style="list-style-type: none"> · Large temperature range. Equally applicable to freezing, refrigeration and air conditioning applications. · Interchangeable orifice assembly <ul style="list-style-type: none"> · easy stocking · easy capacity matching · better service 	<ul style="list-style-type: none"> · Can be supplied with MOP (Max. Operating Pressure) Protects the compressor motor against excessive evaporating pressure during normal operation. · Rated capacities from 0.5 to 15.5 kW for R22. · Valves for special temperature ranges can be supplied. · Flare / solder adaptor can be supplied.

Technical data and ordering

Thermostatic element with: bulb strap, without: orifice, filter cone and nuts

Flare x flare connection

Refrigerant	Valve type	Pressure equalization Flare	Capillary tube	Connection		Code no. ¹⁾					
				Inlet x outlet		Range N -40 to +10°C		Range NM -40 to -5°C	Range NL -40 to -15°C	Range B -60 to -25°C	
				m	in. x in.	mm x mm	Without MOP	MOP +15°C	MOP 0°C	MOP -10°C	Without MOP
R22	TX 2	-	1.5	3/8 x 1/2	10 x 12	068Z3206	068Z3208	068Z3224	068Z3226	068Z3207	068Z3228
	TEX 2	1/4 in.	1.5	3/8 x 1/2	10 x 12	068Z3209	068Z3211	068Z3225	068Z3227	068Z3210	068Z3229
R407C	TZ 2	-	1.5	3/8 x 1/2	10 x 12	068Z3496	068Z3516				
	TEZ 2	1/4 in.	1.5	3/8 x 1/2	10 x 12	068Z3501	068Z3517				
R134a	TN 2	-	1.5	3/8 x 1/2	10 x 12	068Z3346	068Z3347	068Z3393	068Z3369		
	TEN 2	1/4 in.	1.5	3/8 x 1/2	10 x 12	068Z3348	068Z3349	068Z3392	068Z3370		
R404A/R507	TS 2	-	1.5	3/8 x 1/2	10 x 12	068Z3400	068Z3402	068Z3406	068Z3408	068Z3401	068Z3410
	TES 2	1/4 in.	1.5	3/8 x 1/2	10 x 12	068Z3403	068Z3405	068Z3407	068Z3409	068Z3404	068Z3411

Thermostatic element with: bulb strap, without: orifice, filter cone and nuts

Flare x solder connection

Refrigerant	Valve type	Pressure equalization Solder	Capillary tube	Connection		Code no. ¹⁾					
				Inlet Flare	Outlet ODF solder	Range N -40 to +10°C		Range NL -40 to -15°C	Range B -60 to -25°C		
				m		Without MOP	MOP +15°C	MOP -10°C	Without MOP	MOP -20°C	
R22	TX 2	-	1.5	3/8 in.	1/2 in.	068Z3281	068Z3287			068Z3357	068Z3319
	TX 2	-	1.5	10 mm	12 mm	068Z3302	068Z3308	068Z3366		068Z3361	068Z3276
	TEX 2	1/4 in.	1.5	3/8 in.	1/2 in.	068Z3284	068Z3290			068Z3359	068Z3220
	TEX 2	6 mm.	1.5	10 mm	12 mm	068Z3305	068Z3311	068Z3367		068Z3363	068Z3277
R407C	TZ 2	-	1.5	3/8 in.	1/2 in.		068Z3329				
	TZ 2	-	1.5	10 mm	12 mm	068Z3502	068Z3514				
	TEZ 2	1/4 in.	1.5	3/8 in.	1/2 in.	068Z3446	068Z3447				
	TEZ 2	6 mm.	1.5	10 mm	12 mm	068Z3503	068Z3515				
R134a	TN 2	-	1.5	3/8 in.	1/2 in.	068Z3383	068Z3387				
	TN 2	-	1.5	10 mm	12 mm	068Z3384	068Z3388				
	TEN 2	1/4 in.	1.5	3/8 in.	1/2 in.	068Z3385	068Z3389				
	TEN 2	6 mm.	1.5	10 mm	12 mm	068Z3386	068Z3390				
R404A/R507	TS 2	-	1.5	3/8 in.	1/2 in.	068Z3414	068Z3416	068Z3429		068Z3418	068Z3420
	TS 2	-	1.5	10 mm	12 mm	068Z3435	068Z3423	068Z3436		068Z3425	068Z3427
	TES 2	1/4 in.	1.5	3/8 in.	1/2 in.	068Z3415	068Z3417	068Z3430		068Z3419	068Z3421
	TES 2	6 mm.	1.5	10 mm	12 mm	068Z3422	068Z3424	068Z3437		068Z3426	068Z3428

Orifice assembly

Orifice no.	Range N: -40 to +10°C								Range B: -60 to -25°C				Code no. ¹⁾	
	Rated capacity in tons (TR)				Rated capacity in kW				Rated capacity in tons (TR)		Rated capacity in kW		Flare x Flare version ²⁾	Solder adaptor version ²⁾
	R22	R407C	R134a	R404A R507	R22	R407C	R134a	R404A R507	R22	R404A R507	R22	R404A R507		
0X	0.15	0.16	0.11	0.11	0.50	0.50	0.40	0.38	0.15	0.11	0.50	0.38	068-2002	068-2089
00	0.30	0.30	0.25	0.21	1.0	1.1	0.90	0.70	0.20	0.21	0.70	0.70	068-2003	068-2090
01	0.70	0.80	0.50	0.45	2.5	2.7	1.8	1.6	0.30	0.45	1.0	1.6	068-2010	068-2091
02	1.0	1.1	0.80	0.60	3.5	3.8	2.6	2.1	0.60	0.60	2.1	2.1	068-2015	068-2092
03	1.5	1.6	1.3	1.2	5.2	5.6	4.6	4.2	0.80	1.0	2.8	3.5	068-2006	068-2093
04	2.3	2.5	1.9	1.7	8.0	8.6	6.7	6.0	1.2	1.4	4.2	4.9	068-2007	068-2094
05	3.0	3.2	2.5	2.2	10.5	11.3	8.6	7.7	1.5	1.7	5.2	6.0	068-2008	068-2095
06	4.5	4.9	3.0	2.6	15.5	16.7	10.5	9.1	2.0	1.9	7.0	6.6	068-2009	068-2096

The rated capacity is based on: Evaporating temperature $t_e = +5^\circ\text{C}$ for range N and $t_e = -30^\circ\text{C}$ for range B, condensing temperature $t_c = +32^\circ\text{C}$, and refrigerant temperature ahead of valve $t_1 = +28^\circ\text{C}$.

Solder adaptor without orifice assembly

Connection - ODF solder	Code no. ¹⁾
1/4 in.	068-2062
6 mm	068-2063
6 mm	068-4101²⁾
3/8 in.	068-2060
10 mm	068-2061
10 mm	068-4100²⁾

¹⁾ Code numbers in bold are normally on stock and a shorter delivery time can therefore be expected.

²⁾ Including filter.

Filter

Filter type	Code no. ¹⁾
For flare connection	068-0003
For solder adaptor	068-0015

The adaptor is for use with thermostatic expansion valves T2 and TE2. When the adaptor is fitted correctly it meets the sealing requirements of DIN 8964.

The flare orifice in T2 and TE2 can be used with a solder adaptor when the orifice filter is replaced with a specific filter intended for solder adaptors. Only in this way the sealing requirements of DIN 8964 can be fulfilled.

Solder adaptors for filter driers (FSA) must not be used in the T2 inlet.

Capacities

Valve type/ Orifice	Cond. temp. ³⁾ [°C]	R22					R134a					R404A/R507					R407C				
		Capacity in [kW]					Capacity in [kW]					Capacity in [kW]					Capacity in [kW]				
		Evaporating temp. [°C]					Evaporating temp. [°C]					Evaporating temp. [°C]					Evaporating temp. [°C]				
		-35	-30	-10	0	5	-30	-10	-5	0	5	-40	-35	-30	-10	0	-10	-5	0	5	10
T2 / OX	25	0.49	0.51	0.55	0.54	0.51	0.35	0.40	0.41	0.41	0.40	0.33	0.35	0.37	0.42	0.41	0.59	0.59	0.59	0.58	0.55
T2 / 00		0.95	1.00	1.1	1.1	1.1	0.61	0.73	0.75	0.77	0.77	0.61	0.66	0.70	0.85	0.88	1.2	1.2	1.3	1.3	1.2
T2 / 01		1.6	1.7	2.4	2.7	2.7	0.88	1.3	1.5	1.6	1.6	0.96	1.1	1.2	1.8	2.1	2.5	2.7	2.9	3.1	3.2
T2 / 02		2.2	2.5	3.5	3.9	3.9	1.2	1.9	2.0	2.1	2.2	1.3	1.5	1.7	2.6	3.0	3.7	4.0	4.3	4.5	4.6
T2 / 03		3.9	4.3	6.2	6.9	7.0	2.2	3.3	3.6	3.8	4.0	2.4	2.7	3.1	4.7	5.4	6.6	7.1	7.6	8.1	8.3
T2 / 04		5.7	6.4	9.1	10.2	10.5	3.2	4.8	5.2	5.6	5.9	3.5	4.0	4.6	7.0	8.0	9.8	10.6	11.4	12.0	12.5
T2 / 05		7.3	8.0	11.6	13.0	13.3	4.0	6.1	6.6	7.1	7.5	4.5	5.1	5.8	8.9	10.2	12.4	13.4	14.4	15.2	15.7
T2 / 06	8.9	9.8	14.1	15.9	16.3	4.9	7.5	8.2	8.7	9.1	5.5	6.2	7.1	10.8	12.4	15.1	16.4	17.6	18.6	19.2	
T2 / OX	35	0.53	0.55	0.60	0.61	0.60	0.37	0.44	0.45	0.45	0.46	0.32	0.34	0.36	0.42	0.43	0.61	0.62	0.63	0.63	0.62
T2 / 00		1.0	1.1	1.2	1.3	1.3	0.64	0.79	0.83	0.86	0.88	0.59	0.64	0.69	0.86	0.92	1.3	1.3	1.3	1.4	1.4
T2 / 01		1.7	1.8	2.6	3.0	3.2	0.93	1.4	1.6	1.7	1.9	0.92	1.1	1.2	1.8	2.2	2.7	2.9	3.1	3.3	3.5
T2 / 02		2.3	2.6	3.8	4.4	4.7	1.3	2.0	2.2	2.4	2.6	1.2	1.4	1.7	2.7	3.2	3.9	4.3	4.6	5.0	5.3
T2 / 03		4.1	4.6	6.8	7.9	8.4	2.3	3.6	4.0	4.4	4.7	2.2	2.6	3.0	4.8	5.7	7.0	7.6	8.3	8.9	9.4
T2 / 04		6.1	6.8	10.1	11.8	12.5	3.4	5.3	5.8	6.4	6.9	3.3	3.9	4.5	7.1	8.5	10.3	11.3	12.3	13.3	14.2
T2 / 05		7.7	8.6	12.8	14.9	15.8	4.2	6.7	7.4	8.1	8.8	4.3	4.9	5.6	9.0	10.7	13.0	14.3	15.6	16.7	17.8
T2 / 06	9.5	10.5	15.6	18.2	19.3	5.2	8.2	9.1	9.9	10.7	5.2	6.0	6.9	11.0	13.1	15.9	17.4	19.0	20	22	
T2 / OX	45	0.55	0.57	0.64	0.65	0.64	0.38	0.45	0.47	0.48	0.49	0.29	0.31	0.33	0.40	0.42	0.62	0.63	0.64	0.64	0.64
T2 / 00		1.0	1.1	1.3	1.4	1.4	0.65	0.82	0.86	0.90	0.94	0.55	0.60	0.64	0.83	0.90	1.3	1.3	1.3	1.4	1.4
T2 / 01		1.7	1.9	2.8	3.2	3.4	0.96	1.5	1.7	1.8	2.0	0.85	0.98	1.1	1.8	2.1	2.7	2.9	3.2	3.4	3.7
T2 / 02		2.4	2.7	4.0	4.8	5.1	1.3	2.1	2.4	2.6	2.8	1.1	1.3	1.5	2.6	3.2	3.9	4.3	4.7	5.2	5.6
T2 / 03		4.3	4.8	7.2	8.5	9.2	2.3	3.8	4.2	4.7	5.1	1.9	2.3	2.7	4.6	5.7	7.0	7.7	8.5	9.2	9.9
T2 / 04		6.3	7.1	10.7	12.7	13.7	3.4	5.6	6.2	6.9	7.6	3.0	3.5	4.1	6.9	8.4	10.4	11.5	12.6	13.8	14.9
T2 / 05		8.0	9.0	13.6	16.1	17.3	4.3	7.0	7.8	8.7	9.6	3.8	4.4	5.2	8.7	10.6	13.2	14.5	15.9	17.3	18.7
T2 / 06	9.8	11.0	16.6	19.6	21	5.3	8.6	9.6	10.7	11.7	4.7	5.5	6.4	10.6	12.9	16.0	17.7	19.4	21	23	
T2 / OX	55	0.56	0.58	0.65	0.67	0.67	0.38	0.45	0.47	0.49	0.50	0.26	0.28	0.30	0.37	0.39	0.60	0.61	0.62	0.63	0.63
T2 / 00		1.1	1.1	1.3	1.4	1.4	0.63	0.81	0.86	0.90	0.95	0.48	0.53	0.57	0.75	0.82	1.2	1.2	1.3	1.3	1.3
T2 / 01		1.7	1.9	2.8	3.3	3.6	0.95	1.5	1.7	1.9	2.0	0.74	0.86	1.0	1.7	2.0	2.6	2.9	3.1	3.4	3.6
T2 / 02		2.3	2.6	4.1	5.0	5.4	1.2	2.1	2.4	2.7	2.9	0.82	1.0	1.3	2.4	2.9	3.8	4.2	4.7	5.1	5.6
T2 / 03		4.3	4.8	7.4	8.9	9.6	2.2	3.8	4.3	4.8	5.3	1.5	1.8	2.2	4.2	5.3	6.8	7.5	8.3	9.1	9.9
T2 / 04		6.4	7.2	11.0	13.3	14.4	3.4	5.7	6.4	7.2	7.9	2.4	2.9	3.5	6.3	7.8	10.1	11.3	12.4	13.7	14.9
T2 / 05		8.1	9.1	14.0	16.7	18.1	4.2	7.0	8.0	9.0	10.0	3.0	3.7	4.4	7.9	9.9	12.8	14.2	15.7	17.2	18.7
T2 / 06	9.9	11.1	17.0	20	22	5.2	8.7	9.8	11.0	12.1	3.8	4.6	5.4	9.7	12.1	15.6	17.3	19.1	21	23	

3) Condensing temperature at bubble point.

Correction factor

Refrigerant	Subcooling [K]										
	2	4	10	15	20	25	30	35	40	45	50
R22	0.98	1	1.06	1.11	1.15	1.20	1.25	1.30	1.35	1.39	1.44
R134a	0.98	1	1.08	1.13	1.19	1.25	1.31	1.37	1.42	1.48	1.54
R404A/R507	0.96	1	1.10	1.20	1.29	1.37	1.46	1.54	1.63	1.70	1.78
R407C	0.97	1	1.08	1.14	1.21	1.27	1.33	1.39	1.45	1.51	1.57

When the subcooling ≠ 4 K then:

1. Table value x Factor = Plant capacity
2. Plant capacity / Factor = Table value

Example:

Refrigerant = R407C

$Q_{nom} = 10 \text{ kW}$

$t_e = 0^\circ\text{C}$

$t_c = 55^\circ\text{C}$

$\Delta t_{sub} = 25 \text{ K}$

Selection:

1. T2, Orifice 04 = $12.4 \text{ kW} \times 1.27 = 15.75 \text{ kW}$ Valve too large

Right selection:

2. $10 \text{ kW} / 1.27 = 7.9 \text{ kW}$ T2, Orifice 03

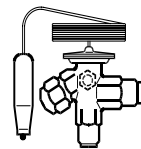

Thermostatic valve



Orifice

The complete Danfoss program of thermostatic expansion valves:

Type	Rated capacities in kW for range N					Connections
	R22	R134a	R404A / R507	R407C	R410A	
T 2 and TE 2 ¹⁾	0.5 - 15.5	0.4 - 10.5	0.38 - 9.1	0.5 - 16.7	-	Flare x flare and flare x solder Solder x solder (solder adaptor)
TUA and TUAE ¹⁾	0.6 - 16	0.45 - 12	0.45 - 12	0.63 - 17	1.3 - 26	Solder Bi-metal (stainless steel / copper)
TUB and TUBE ²⁾	0.9 - 16	0.7 - 12	0.7 - 12	0.92 - 17	1.3 - 26	Solder Bi-metal (stainless steel / copper)
TCAE ¹⁾ and TCBE ²⁾	17.5 - 26.5	12 - 18	13.5 - 20	19.0 - 28.5	23 - 34	Solder Bi-metal (stainless steel / copper)
TRE 10 - TRE 80 ²⁾	28 - 245	18 - 196	21 - 187	28 - 245	28 - 350	Solder Bi-metal (stainless steel / copper)
TE 5 - TE 55 ¹⁾	19.7 - 356	12.9 - 220	13 - 197	21.3 - 385	-	Flare / solder /solder flanges
PHT ¹⁾	105 - 1890	55 - 1083	99 - 1623	117 - 2020	-	Solder or weld flanges
TDE and TDEB ²⁾	10.5 - 140	5.7 - 79	8.4 - 109	10.5 - 140	-	Solder (copper)

¹⁾ Interchangeable orifice.

²⁾ Fixed orifice.

Thermostatic expansion valves parts program:

T 2 and TE 2

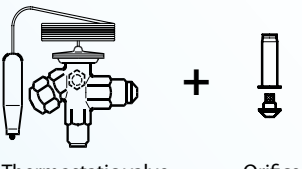

Thermostatic valve + Orifice



TUA/TUAE and TCAE

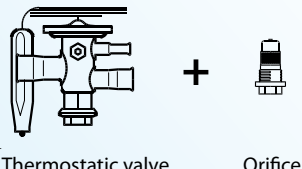

Thermostatic valve + Orifice

TE 5 - TE 55

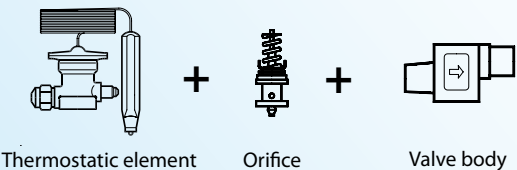

Thermostatic element + Orifice + Valve body

PHT

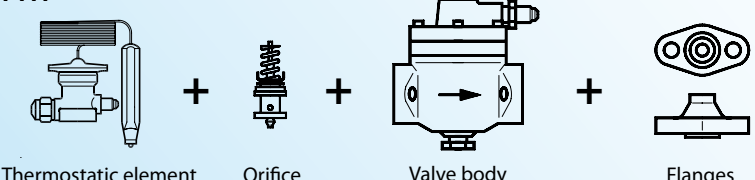

Thermostatic element + Orifice + Valve body + Flanges



TE5-55: flexible solution for medium sized refrigeration plants

Thermostatic expansion valves TE5-55 regulate the injection of refrigerant liquid into evaporators for medium sized plants (rated capacities from 19 to 356 kW for R22). Injection is controlled by the refrigerant superheat. Therefore the valves are especially suitable for liquid injection in "dry" evaporators where the superheat at the evaporator outlet is proportional to the evaporator load.

Features

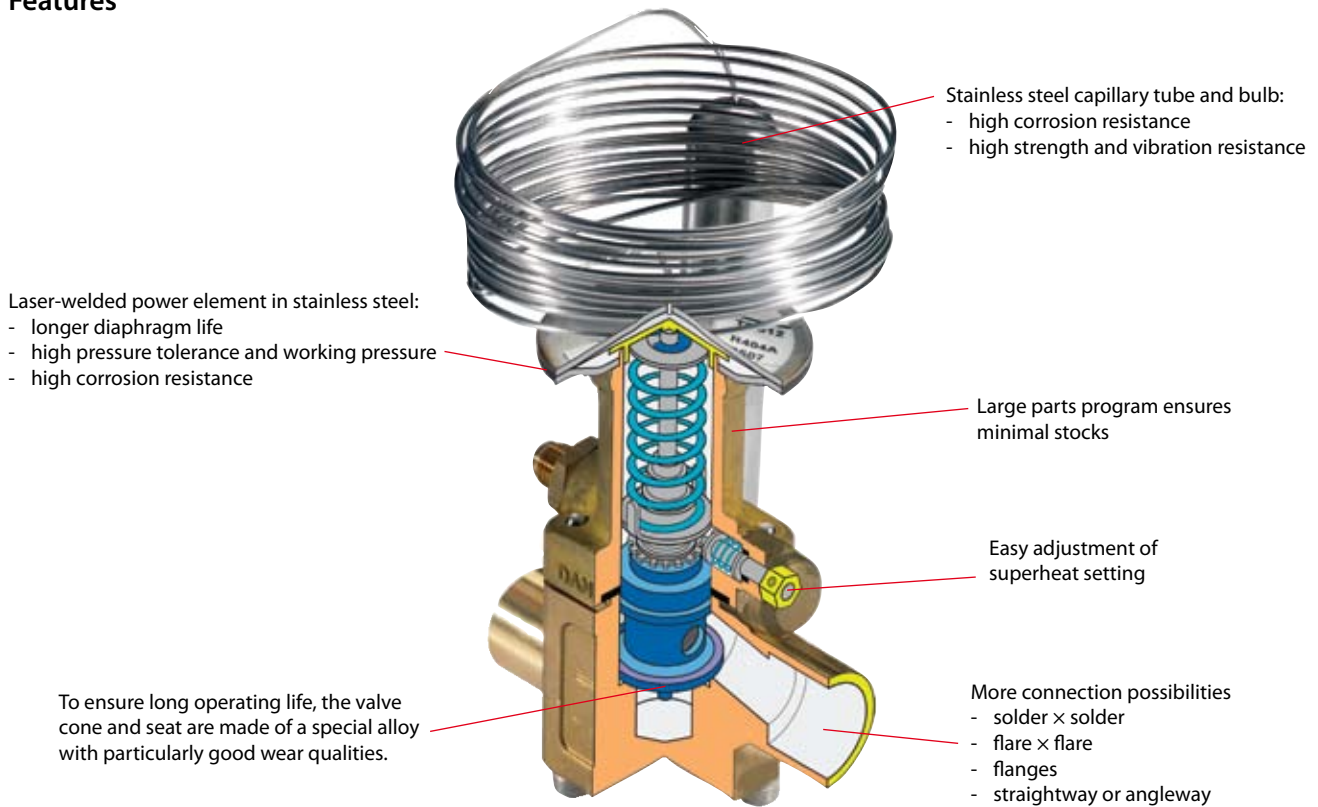

Applications	Advantages	Facts
<ul style="list-style-type: none"> • Traditional refrigeration • Air conditioning units • Ice cube machines • Water chillers 	<ul style="list-style-type: none"> • Interchangeable orifice assembly designed for: <ul style="list-style-type: none"> • Easy assembly and mounting • Optimised capacity matching • Balanced port (TE55 only) • Large temperature range -60 to +10°C 	<ul style="list-style-type: none"> • Available with MOP (Max. Operating Pressure). Protects the compressor motor against excessive evaporating pressure. • Rated capacities: <ul style="list-style-type: none"> TE5-20: From 19.7 to 108 kW for R22 TE55: From 239 to 356 kW for R22 • Refrigerants: R22, R134a, R404A/R507 and R407C • Maximum Working Pressure: 28 bar

Technical data and ordering: Orifice assembly

Orifice assembly

R22

Valve type	Rated capacity Range N: -40 to 10°C kW ¹⁾	Rated capacity Range B: -60 to -25°C kW ¹⁾	Orifice no.	Code no. ²⁾
TEX 5-3	19.7	11.9	01	067B2089
TEX 5-4.5	26.9	16.7	02	067B2090
TEX 5-7.5	38.8	24.8	03	067B2091
TEX 5-12	55.3	35.4	04	067B2092
TEX 12-4.5	26.8	17.2	01	067B2005
TEX 12-7.5	43.4	28.2	02	067B2006
TEX 12-12	64.0	41.4	03	067B2007
TEX 12-18	84.4	55.9	04	067B2008
TEX 20-30	108.0	70.0	01	067B2172
TEX 55-50	239.0	148.0	01	067G2005
TEX 55-85	356.0	228.0	02	067G2006

Orifice assembly

R134a

Valve type	Rated capacity Range N: -40 to 10°C kW ¹⁾	Orifice no.	Code no. ²⁾
TEN 5-3.7	12.9	01	067B2089
TEN 5-5.4	19.1	02	067B2090
TEN 5-8.3	29.1	03	067B2091
TEN 5-11.2	39.6	04	067B2092
TEN 12-4.7	16.7	01	067B2005
TEN 12-7.7	27.2	02	067B2006
TEN 12-11.4	40.0	03	067B2007
TEN 12-15	53.0	04	067B2008
TEN 20-18	65.0	01	067B2170
TEN 55-41	145.0	01	067G2001
TEN 55-62	220.0	02	067G2002

Orifice assembly

R404A/R507

Valve type	Rated capacity range N: -40 to 10°C kW ¹⁾	Rated capacity range B: -60 to -25°C kW ¹⁾	Orifice no.	Code no. ²⁾
TES 5-3.7	13.0	8.0	01	067B2089
TES 5-5.0	17.6	11.2	02	067B2090
TES 5-7.2	25.3	16.6	03	067B2091
TES 5-10.3	36.2	23.7	04	067B2092
TES12-4.2	14.8	11.6	01	067B2005
TES 12-6.8	23.9	18.9	02	067B2006
TES 12-10.0	35.2	27.7	03	067B2007
TES 12-13.4	47.1	37.5	04	067B2008
TES 20-16.5	59.0	41.0	01	067B2175
TES 55-37.0	130.0	95.0	01	067G2011
TES 55-56.0	197.0	144.0	02	067G2012

Orifice assembly

R407C

Valve type	Rated capacity Range N: -40 to 10°C kW ¹⁾	Orifice no.	Code no. ²⁾
TEZ 5-3.2	21.3	01	067B2089
TEZ 5-5.0	29.1	02	067B2090
TEZ 5-8.0	41.9	03	067B2091
TEZ 5-13	59.7	04	067B2092
TEZ 12-5.0	28.9	01	067B2005
TEZ 12-8.0	46.9	02	067B2006
TEZ 12-13	69.1	03	067B2007
TEZ 12-19.5	91.2	04	067B2008
TEZ 20-32.5	116.0	01	067B2172
TEZ 55-54	259.0	01	067G2005
TEZ 55-92	385.0	02	067G2006

¹⁾ The rated capacity is based on:
 Evaporating temperature $t_e = +5^\circ\text{C}$ for range N and $t_e = -30^\circ\text{C}$ for range B,
 Condensing temperature $t_c = +32^\circ\text{C}$
 Refrigerant temperature ahead of valve $t_i = +28^\circ\text{C}$

²⁾ Code numbers in bold are normally on stock and a shorter delivery time can therefore be expected.

When the subcooling $\neq 4\text{ K}$ then:

- Table value x Factor = Plant capacity
- Plant capacity / Factor = Table value

Example:

Refrigerant = R404A

$Q_{nom} = 10\text{ kW}$

$t_e = -10^\circ\text{C}$

$t_c = 45^\circ\text{C}$

$Dt_{sub} = 25\text{ K}$

Selection:

- TE5, Orifice 03 = $15.3\text{ kW} \times 1.46 = 22.34\text{ kW}$ Valve too large

Right selection:

- $10\text{ kW} / 1.46 = 6.85\text{ kW}$ TE5, Orifice 01

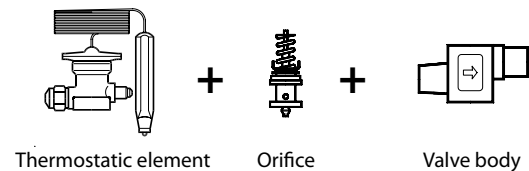

Capacities

Valve type / Orifice	Cond. temp. ³⁾ [°C]	R22					R134a					R404A/R507					R407C				
		Capacity in [kW]					Capacity in [kW]					Capacity in [kW]					Capacity in [kW]				
		Evaporating temp. [°C]					Evaporating temp. [°C]					Evaporating temp. [°C]					Evaporating temp. [°C]				
		-35	-30	-10	0	5	-30	-10	-5	0	5	-40	-35	-30	-10	0	-10	-5	0	5	10
TE5 / 01	25	9.9	11.1	17.3	18.4	17.7	5.7	9.3	10.1	10.9	11.4	5.8	6.5	7.4	12.2	13.7	18.4	19.6	20	20	18.9
TE5 / 02		13.9	15.6	24	25	24	8.6	13.9	15.2	16.2	16.9	8.1	9.1	10.5	16.7	18.6	25	27	28	27	26
TE5 / 03		21	23	34	36	35	12.6	20	22	24	25	12.6	14.0	15.9	25	27	37	39	40	40	38
TE5 / 04		29	33	49	52	50	18.0	29	32	34	35	17.9	19.9	23	35	39	52	55	57	57	53
TE12 / 01		14.8	16.3	23	24	23	8.5	12.7	13.6	14.3	14.7	7.7	8.6	9.6	14.0	15.6	24	25	26	27	26
TE12 / 02		24	27	37	39	38	13.9	21	22	23	24	12.3	14.1	15.8	23	25	39	41	43	43	42
TE12 / 03		35	39	54	57	55	20	30	32	34	35	18.4	21	23	33	37	57	61	63	63	61
TE12 / 04		47	52	72	75	73	27	40	43	45	47	26	29	32	45	49	77	81	83	84	81
TE20 / 01		60	67	90	96	95	33	50	54	57	58	31	35	39	55	61	96	102	106	108	108
TE55 / 01		128	142	198	212	211	73	110	119	125	128	62	72	82	121	136	210	224	234	241	240
TE55 / 02	196	218	298	318	317	113	169	182	192	197	97	112	127	184	206	317	336	351	360	358	
TE5 / 01	35	10.5	12.0	19.0	21	21	6.0	10.1	11.2	12.3	13.3	5.6	6.3	7.4	12.5	14.6	19.3	21	22	22	21
TE5 / 02		14.8	16.7	26	28	28	9.2	15.2	16.8	18.3	19.7	7.9	9.0	10.4	17.2	19.8	26	28	30	30	29
TE5 / 03		22	25	38	41	41	13.6	22	25	27	28	12.5	14.0	16.0	26	29	39	41	43	43	42
TE5 / 04		32	36	54	59	58	19.4	32	35	38	41	17.8	20.0	23	37	41	55	59	61	62	60
TE12 / 01		15.7	17.5	25	27	28	9.0	13.9	15.2	16.3	17.3	7.3	8.3	9.4	14.5	17.0	25	27	29	29	30
TE12 / 02		26	29	40	44	45	14.8	23	25	27	28	12.0	13.8	15.7	23	27	41	44	46	47	48
TE12 / 03		38	42	59	65	65	22	33	36	39	41	18.4	21	24	35	40	61	65	68	69	70
TE12 / 04		52	57	79	86	87	29	44	48	52	55	26	30	33	47	53	81	86	90	92	91
TE20 / 01		65	72	99	109	112	36	55	60	64	68	31	35	40	57	66	101	108	114	119	122
TE55 / 01		135	151	217	242	249	77	121	132	142	151	59	69	80	124	145	220	237	252	264	272
TE55 / 02	208	232	327	362	372	119	184	201	216	229	93	108	124	189	219	332	356	377	393	404	
TE5 / 01	45	10.9	12.5	20	22	23	6.1	10.5	11.8	13.1	14.3	5.1	5.9	6.9	12.4	14.7	19.5	21	22	23	22
TE5 / 02		15.4	17.5	27	30	31	9.4	15.9	17.7	19.5	21	7.2	8.3	9.8	16.9	19.9	27	29	30	31	30
TE5 / 03		24	27	40	44	44	14.1	24	26	29	31	11.8	13.3	15.3	25	29	39	42	44	44	43
TE5 / 04		34	38	57	63	63	20	34	37	41	44	16.8	19.0	22	36	42	56	60	62	63	62
TE12 / 01		16.2	18.2	26	29	30	9.2	14.6	16.0	17.5	18.8	6.2	7.2	8.4	14.0	17.0	26	28	29	30	31
TE12 / 02		27	30	43	48	49	15.1	24	26	28	31	11.0	12.8	14.7	23	27	41	45	47	49	50
TE12 / 03		40	44	63	70	72	22	35	38	42	45	17.4	20.0	23	34	40	61	66	69	72	73
TE12 / 04		55	60	85	93	95	30	47	51	56	60	26	29	32	47	55	83	88	92	95	95
TE20 / 01		69	76	105	118	122	37	58	63	69	74	29	34	38	57	67	102	110	116	122	127
TE55 / 01		139	156	229	260	272	77	126	139	152	164	53	63	74	121	146	221	239	256	272	284
TE55 / 02	215	240	345	388	404	120	192	211	229	247	83	99	115	184	220	333	359	382	403	419	
TE5 / 01	55	11.0	12.7	21	23	24	5.9	10.6	12.0	13.4	14.8	4.2	5.0	6.1	11.7	14.2	19.1	21	22	22	22
TE5 / 02		15.6	17.8	28	32	32	9.1	15.9	17.9	19.9	22	6.1	7.2	8.7	16.1	19.3	26	28	30	30	30
TE5 / 03		24	27	41	46	46	14.2	24	27	29	32	10.4	11.9	14.0	24	28	38	41	43	43	42
TE5 / 04		34	39	59	65	66	20	34	38	42	45	14.8	17.0	20	35	41	55	58	61	62	61
TE12 / 01		16.3	18.4	27	31	32	9.1	14.8	16.4	18.0	19.5	4.4	5.4	6.6	12.6	15.9	25	27	29	30	31
TE12 / 02		27	30	44	49	51	14.7	24	27	29	32	9.3	11.1	13.1	22	26	40	43	46	48	50
TE12 / 03		41	45	65	72	75	22	35	39	43	46	15.5	18.0	21	33	39	60	64	68	71	72
TE12 / 04		57	63	88	96	99	31	48	53	57	62	24	27	30	45	53	81	86	90	93	94
TE20 / 01		70	78	109	122	128	37	59	65	71	76	26	30	35	54	64	100	107	114	120	126
TE55 / 01		138	156	233	268	283	74	126	140	155	169	43	53	64	113	140	213	232	250	267	281
TE55 / 02	215	242	352	399	419	117	192	213	234	254	69	85	101	172	210	320	347	371	393	412	

3) Condensing temperature at bubble point.

Correction factor

Refrigerant	Subcooling [K]										
	2	4	10	15	20	25	30	35	40	45	50
R22	0.98	1	1.06	1.11	1.15	1.20	1.25	1.30	1.35	1.39	1.44
R134a	0.98	1	1.08	1.13	1.19	1.25	1.31	1.37	1.42	1.48	1.54
R404A/R507	0.96	1	1.10	1.20	1.29	1.37	1.46	1.54	1.63	1.70	1.78
R407C	0.97	1	1.08	1.14	1.21	1.27	1.33	1.39	1.45	1.51	1.57

Technical data and ordering: TE5-55

Thermostatic element, without orifice and filter, with bulb strap

R22, R134a, R404A/R507, R407C

Refrigerant	Valve type	Pressure equalization ¼ in. / 6 mm	Capillary tube m	Code no. ²⁾					
				Range N -40 to +10°C		Range NM -40 to -5°C	Range NL -40 to -15°C	Range B -60 to -25°C	
				Without MOP	MOP+15°C	MOP 0°C	MOP -10°C	Without MOP	MOP -20°C
R22	TEX 5	Ext. ⁴⁾	3	067B3250	067B3267	067B3249	067B3253	067B3263	067B3251
	TEX 12	Ext. ⁵⁾	3	067B3210	067B3227	067B3207	067B3213		067B3211
	TEX 12	Ext. ⁵⁾	5	067B3209					067B3212
	TEX 20	Ext. ⁵⁾	3	067B3274	067B3286	067B3273	067B3275		067B3276
	TEX 20	Ext. ⁵⁾	5	067B3290					067B3287
	TEX 55	Ext. ⁵⁾	3	067G3205	067G3220	067G3206			067G3207
R134a	TEN 5	Ext. ⁴⁾	3	067B3297	067B3298	067B3360			
	TEN 12	Ext. ⁵⁾	3	067B3232	067B3233				
	TEN 12	Ext. ⁵⁾	5	067B3363					
	TEN 20	Ext. ⁵⁾	3	067B3292	067B3293				
	TEN 20	Ext. ⁵⁾	5	067B3370					
	TEN 55	Ext. ⁵⁾	3	067G3222	067G3223				
R404A/R507	TES 5	Ext. ⁴⁾	3	067B3342		067B3357	067B3358	067B3344	067B3343
	TES 12	Ext. ⁵⁾	3	067B3347		067B3345	067B3348		067B3349
	TES 12	Ext. ⁵⁾	5	067B3346					067B3350
	TES 20	Ext. ⁵⁾	3	067B3352		067B3351	067B3353		067B3354
	TES 20	Ext. ⁵⁾	5	067B3356					067B3355
	TES 55	Ext. ⁵⁾	3	067G3302		067G3303	067G3304		067G3305
R407C	TEZ 5	Ext. ⁴⁾	3	067B3278	067B3277				
	TEZ 12	Ext. ⁵⁾	3	067B3366	067B3367				
	TEZ 20	Ext. ⁵⁾	3	067B3371	067B3372				
	TEZ 55	Ext. ⁵⁾	3	067G3240	067G3241				

Valve body

Type	Orifice no. ⁶⁾	Connection Inlet × Outlet		Code no. ²⁾			
		in.	mm	Flare angleway	Solder angleway	Solder straightway	Solder flanges
TE 5	01 - 03 03 04	½ × ⅝ ½ × ⅞ ⅝ × ⅞		067B4013	067B4009 067B4010 067B4011	067B4007 067B4008	
TE 5	01 - 03 03 04		12 × 16 12 × 22 16 × 22	067B4013	067B4004 067B4005 067B4012	067B4002 067B4003	
TE 12	01 - 02 03 - 04 03 - 04	⅝ × ⅞ ⅞ × 1 ⅞ × 1½			067B4022 ⁷⁾ 067B4023 ⁸⁾	067B4020 ⁷⁾ 067B4021 ⁸⁾	067B4025 ⁷⁾ 067B4026 ⁷⁾
TE 12	01 - 02 03 - 04 03 - 04		16 × 22 22 × 25 22 × 28		067B4017 ⁸⁾	067B4018 ⁷⁾ 067B4016 ⁸⁾	067B4027 ⁷⁾ 067B4015 ⁷⁾
TE 20	01 01	⅞ × 1½	22 × 28		067B4023 ⁸⁾ 067B4017 ⁸⁾	067B4021 ⁸⁾ 067B4016 ⁸⁾	
TE 55	01 - 02 01 - 02	1½ × 1¾	28 × 35		067G4004 ⁹⁾ 067G4002 ⁹⁾	067G4003 ⁹⁾ 067G4001 ⁹⁾	

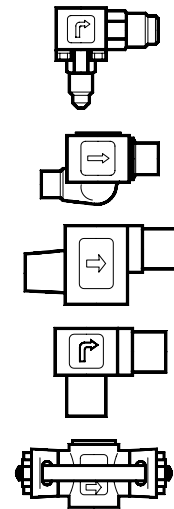

⁴⁾ Pressure equalization with solder connector can be supplied on contacting Danfoss.

⁵⁾ Available as accessory: solder adaptor for TE 12, TE 20 and TE 55. Code no. **068B0170**.

⁶⁾ Suggested orifice/valve body combination.

⁷⁾ ODF × ODF

⁸⁾ ODF × ODM

⁹⁾ ODM × ODM

ODF = Internal diameter

ODM = External diameter



TU / TC: superior by design and function

The function of a thermostatic expansion valve is determined by three fundamental pressures: the bulb pressure, the evaporating pressure and the spring pressure. When the expansion valve regulates, balance is created between bulb pressure on one side of the diaphragm and evaporating pressure plus spring force on the other side. The spring is used to set superheat.

Features

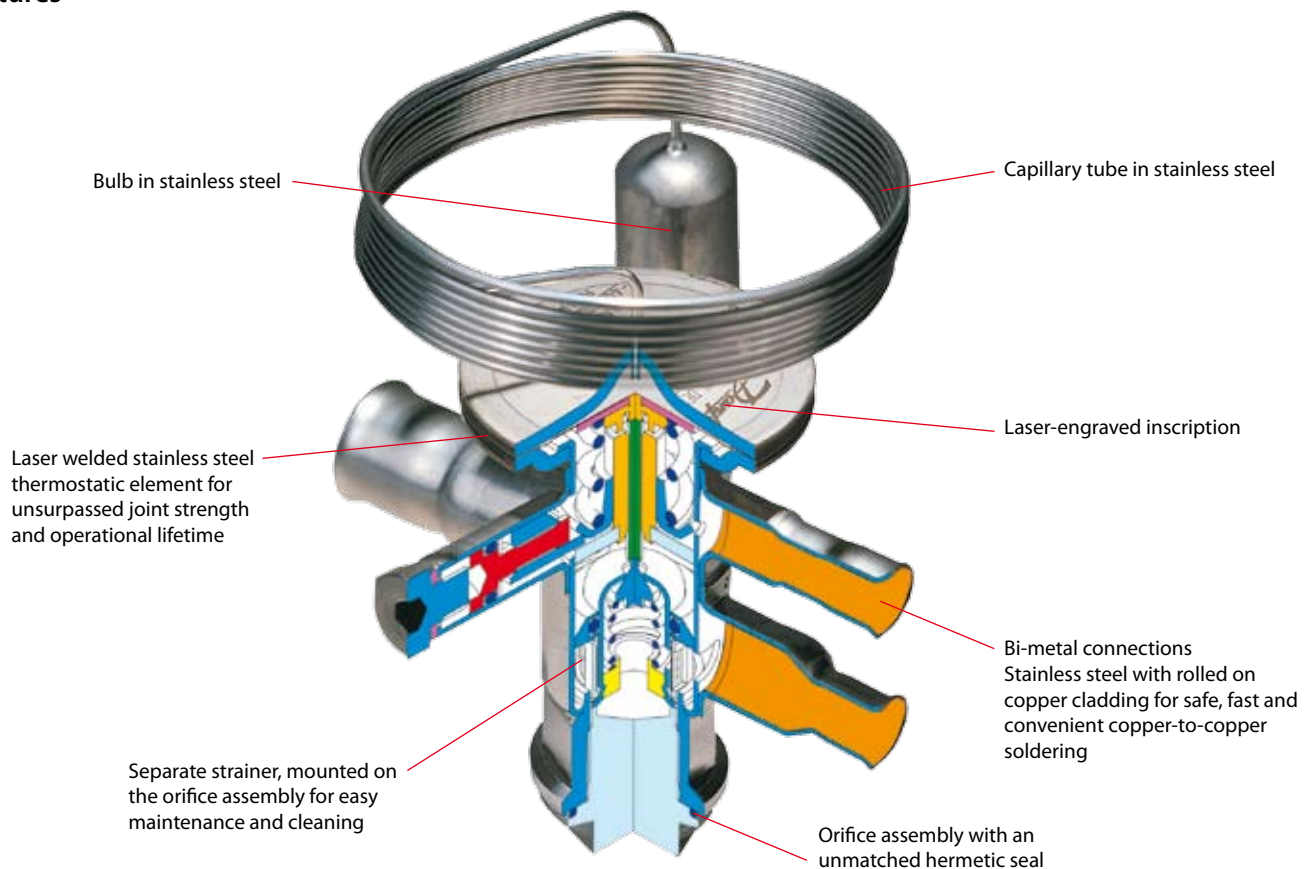

Applications	Advantages	Facts
<ul style="list-style-type: none"> · Traditional refrigeration · Heat pump systems · Air conditioning units · Liquid coolers · Ice cube machines · Transport refrigeration 	<ul style="list-style-type: none"> · The use of stainless steel makes the valves light and strong. · Bi-metal connections for safe, fast and convenient soldering. · Stainless steel capillary tube for superior strength and ductility. · Allen key superheat setting screw is convenient and space-saving compared to the standard screwdriver adjustment used in most conventional valves. 	<ul style="list-style-type: none"> · Can be supplied with MOP (Max. Operating Pressure) Protects the compressor motor against excessive evaporating pressure during normal operation. · Valves for special temperature ranges can be supplied. · Only 4 K opening superheat. · Bi-flow function.

Technical data and ordering: TUA / TUAE

Thermostatic element, without orifice and filter, with bulb strap ¹⁾

R22, R134a, R404A/R507, R407C, R410A

Refrigerant	Type	Pressure equalization	Connections Inlet x outlet		Code no. ²⁾				
					Range N -40 to +10°C		Range NM -40 to -5°C	Range B -60 to -25°C	
					Without MOP	MOP +15°C	MOP 0°C	Without MOP	MOP -20°C
R22	TUA	Int.	1/4 x 1/2	6 x 12	068U2234	068U2242			
	TUA	Int.	3/8 x 1/2		068U2230	068U2238			
	TUA	Int.			068U2235	068U2243			
	TUA	Int.			068U2231	068U2239			
	TUAE	Ext. 1/4 in.	1/4 x 1/2	6 x 12	068U2236	068U2244			
	TUAE	Ext. 6 mm	3/8 x 1/2		068U2232	068U2240			
	TUAE	Ext. 1/4 in.			068U2237	068U2245			
	TUAE	Ext. 6 mm			068U2233	068U2241			
R134a	TUA	Int.	1/4 x 1/2	6 x 12	068U2204	068U2212			
	TUA	Int.	3/8 x 1/2		068U2200	068U2208			
	TUA	Int.			068U2205	068U2213			
	TUA	Int.			068U2201	068U2209			
	TUAE	Ext. 1/4 in.	1/4 x 1/2	6 x 12	068U2206	068U2214			
	TUAE	Ext. 6 mm	3/8 x 1/2		068U2202	068U2210			
	TUAE	Ext. 1/4 in.			068U2207	068U2215			
	TUAE	Ext. 6 mm			068U2203	068U2211			
R404A/R507	TUA	Int.	1/4 x 1/2	6 x 12	068U2284	068U2292	068U2300	068U2308	068U2316
	TUA	Int.	3/8 x 1/2		068U2280	068U2288	068U2296	068U2304	068U2312
	TUA	Int.			068U2285	068U2293	068U2301	068U2309	068U2317
	TUA	Int.			068U2281	068U2289	068U2297	068U2305	068U2313
	TUAE	Ext. 1/4 in.	1/4 x 1/2	6 x 12	068U2286	068U2294	068U2302	068U2310	068U2318
	TUAE	Ext. 6 mm	3/8 x 1/2		068U2282	068U2290	068U2298	068U2306	068U2314
	TUAE	Ext. 1/4 in.			068U2287	068U2295	068U2303	068U2311	068U2319
	TUAE	Ext. 6 mm			068U2283	068U2291	068U2299	068U2307	068U2315
R407C	TUA	Int.	1/4 x 1/2	6 x 12	068U2324	068U2332			
	TUA	Int.	3/8 x 1/2		068U2320	068U2328			
	TUA	Int.			068U2325	068U2333			
	TUA	Int.			068U2321	068U2329			
	TUAE	Ext. 1/4 in.	1/4 x 1/2	6 x 12	068U2326	068U2334			
	TUAE	Ext. 6 mm	3/8 x 1/2		068U2322	068U2330			
	TUAE	Ext. 1/4 in.			068U2327	068U2335			
	TUAE	Ext. 6 mm			068U2323	068U2331			
R410A	TUA		3/8 x 1/2		068U2414				
	TUAE		3/8 x 1/2	10 x 12	068U1714				068U2450

Orifice assembly with filter and gasket

Orifice no.	Range N: -40 to +10°C										Range B: -60 to -25°C						Code no. ²⁾
	Rated capacity in kW ³⁾					Rated capacity in tons (TR)					Rated capacity in kW ³⁾			Rated capacity in tons (TR)			
	R22	R134a	R404A R507	R407C	R410A	R22	R134a	R404A R507	R407C	R410A	R22	R404A R507	R407C	R22	R404A R507	R407C	
0	0.60	0.47	0.45	0.63	-	0.17	0.13	0.13	0.18	-	0.52	0.36	0.46	0.15	0.10	0.13	068U1030
1	0.9	0.7	0.66	0.92	1.3	0.25	0.19	0.19	0.26	0.4	0.68	0.50	0.58	0.19	0.14	0.16	068U1031
2	1.3	1.0	1.0	1.4	2.1	0.36	0.28	0.27	0.38	0.6	0.85	0.64	0.70	0.24	0.18	0.20	068U1032
3	1.8	1.4	1.3	1.9	2.9	0.50	0.39	0.38	0.53	0.8	1.2	0.89	1.0	0.34	0.25	0.28	068U1033
4	2.6	2.1	2.0	2.8	4.5	0.75	0.59	0.57	0.80	1.3	1.8	1.3	1.4	0.50	0.37	0.41	068U1034
5	3.5	2.7	2.7	3.8	5.9	1.00	0.78	0.76	1.1	1.7	2.3	1.8	1.9	0.66	0.50	0.55	068U1035
6	5.3	4.1	4.0	5.7	9.0	1.5	1.2	1.1	1.6	2.5	3.5	2.7	2.9	1.0	0.75	0.82	068U1036
7	7.0	5.5	5.3	7.5	12.0	2.0	1.6	1.5	2.1	3.4	4.7	3.5	3.9	1.3	1.0	1.1	068U1037
8	11.0	8.2	8.0	11.0	18.0	3.0	2.3	2.3	3.2	5.0	7.1	5.3	5.8	2.0	1.5	1.6	068U1038
9	16.0	12.0	12.0	17.0	26.0	4.5	3.5	3.5	4.8	7.5	10.4	7.8	8.5	2.9	2.2	2.4	068U1039

¹⁾ Capillary tube length 1.5 m.

²⁾ Code numbers in bold are normally on stock and a shorter delivery time can therefore be expected.

³⁾ The rated capacity is based on: Evaporating temperature $t_e = +5^\circ\text{C}$ for range N and $t_e = -30^\circ\text{C}$ for range B, condensing temperature $t_c = +32^\circ\text{C}$, refrigerant temperature ahead of valve $t_1 = +28^\circ\text{C}$, and opening superheat OS = 4 K.

Technical data and ordering: TCAE

Thermostatic element, without orifice and filter, with bulb strap ⁴⁾

R22, R134a, R404A/R507, R407C, R410A

Refrigerant	Type	Pressure equalization	Connection Inlet x outlet		Code no.				
					Range N -40 to +10°C		Range NM -40 to -5°C	Range B -60 to -25°C	
			in.	mm	Without MOP	With MOP	MOP 0°C	Without MOP	With MOP
R22	TCAE	ext.	$\frac{3}{8} \times \frac{5}{8}$		068U4280	068U4282	068U4288		
	TCAE	$\frac{1}{4}$ in.	$\frac{1}{2} \times \frac{5}{8}$		068U4281	068U4283	068U4289		
	TCAE	ext.		10 x 16	068U4284	068U4286	068U4290		
	TCAE	6 mm		12 x 16	068U4285	068U4287	068U4291		
R134a	TCAE	ext.	$\frac{3}{8} \times \frac{5}{8}$		068U4292	068U4294	068U4300		
	TCAE	$\frac{1}{4}$ in.	$\frac{1}{2} \times \frac{5}{8}$		068U4293	068U4295	068U4301		
	TCAE	ext.		10 x 16	068U4296	068U4298	068U4302		
	TCAE	6 mm		12 x 16	068U4297	068U4299	068U4303		
R404A/R507	TCAE	ext.	$\frac{3}{8} \times \frac{5}{8}$		068U4304	068U4306	068U4312	068U4316	068U4318
	TCAE	$\frac{1}{4}$ in.	$\frac{1}{2} \times \frac{5}{8}$		068U4305	068U4307	068U4313	068U4317	068U4319
	TCAE	ext.		10 x 16	068U4308	068U4310	068U4314	068U4320	068U4322
	TCAE	6 mm		12 x 16	068U4309	068U4311	068U4315	068U4321	068U4323
R407C	TCAE	ext.	$\frac{3}{8} \times \frac{5}{8}$		068U4324	068U4326	068U4332		
	TCAE	$\frac{1}{4}$ in.	$\frac{1}{2} \times \frac{5}{8}$		068U4325	068U4327	068U4333		
	TCAE	ext.		10 x 16	068U4328	068U4330	068U4334		
	TCAE	$\frac{1}{4}$ in.		12 x 16	068U4329	068U4331	068U4335		
R410A	TCAE	ext.	$\frac{3}{8} \times \frac{5}{8}$		068U4336	068U4338	068U4344		
	TCAE	$\frac{1}{4}$ in.	$\frac{1}{2} \times \frac{5}{8}$		068U4337	068U4339	068U4345		
	TCAE	ext.		10 x 16	068U4340	068U4342	068U4346		
	TCAE	6 mm		12 x 16	068U4341	068U4343	068U4347		

Orifice assembly with filter and gasket

Orifice no.	Range N: -40 to +10°C										Code no.	
	Rated capacity in kW ⁵⁾					Rated capacity in tons (TR)					Without bleed	With 15% bleed
	R22	R134a	R404A R507	R407C	R410A	R22	R134a	R404A R507	R407C	R410A		
01	17.5	12.0	13.5	19.0	23.0	5.0	3.5	3.8	5.4	6.5	068U4100	068U4097
02	21.0	14.5	16.0	23.0	27.5	6.0	4.1	4.5	6.5	7.8	068U4101	068U4098
03 ⁶⁾	26.5	18.0	20.0	28.5	34.0	7.5	5.2	5.7	8.1	9.8	068U4102	068U4099

⁴⁾ Capillary tube length 1.5 m.

⁵⁾ The rated capacity is based on: Evaporating temperature $t_e = +5^\circ\text{C}$, condensing temperature $t_c = +32^\circ\text{C}$, refrigerant temperature ahead of valve $t_1 = +28^\circ\text{C}$, and opening superheat OS = 4 K.

⁶⁾ TCAE with orifice no. 3 cannot be used for biflow operation.

Capacities

Valve type/ Orifice	Cond. temp. ⁷⁾ [°C]	R22					R134a					R404A/R507					R407C				
		Capacity in [kW]					Capacity in [kW]					Capacity in [kW]					Capacity in [kW]				
		Evaporating temp. [°C]					Evaporating temp. [°C]					Evaporating temp. [°C]					Evaporating temp. [°C]				
		-35	-30	-10	0	5	-30	-10	-5	0	5	-40	-35	-30	-10	0	-10	-5	0	5	10
TU/00	25	0.38	0.41	0.53	0.55	0.54	0.27	0.38	0.40	0.41	0.42	0.25	0.28	0.31	0.40	0.43	0.54	0.58	0.61	0.61	0.58
TU/01		0.44	0.50	0.72	0.79	0.79	0.31	0.52	0.57	0.60	0.62	0.28	0.33	0.38	0.56	0.62	0.75	0.80	0.85	0.88	0.89
TU/02		0.51	0.59	0.94	1.1	1.1	0.35	0.67	0.75	0.83	0.89	0.33	0.4	0.5	0.7	0.9	0.96	1.1	1.2	1.3	1.3
TU/03		0.73	0.84	1.3	1.5	1.5	0.49	0.94	1.0	1.1	1.2	0.5	0.5	0.6	1.1	1.2	1.3	1.5	1.6	1.7	1.8
TU/04		1.1	1.2	1.9	2.2	2.3	0.72	1.4	1.6	1.7	1.8	0.7	0.8	0.9	1.6	1.8	2.0	2.2	2.4	2.6	2.8
TU/05		1.4	1.6	2.6	3.0	3.1	0.99	1.9	2.1	2.3	2.4	0.9	1.1	1.3	2.1	2.5	2.7	3.0	3.2	3.5	3.7
TU/06		2.1	2.4	3.9	4.5	4.7	1.4	2.8	3.1	3.5	3.7	1.4	1.6	1.9	3.1	3.7	4.0	4.4	4.9	5.3	5.6
TU/07		2.8	3.2	5.2	6.0	6.3	1.9	3.7	4.2	4.6	4.9	1.8	2.1	2.5	4.2	4.9	5.3	5.9	6.5	7.0	7.4
TU/08		4.2	4.9	7.8	9.0	9.3	2.9	5.6	6.3	6.9	7.3	2.8	3.3	3.8	6.3	7.3	8.0	8.9	9.7	10.5	11.0
TU/09		6.2	7.1	11.6	13.4	14.0	4.3	8.2	9.3	10.2	10.9	4.0	4.8	5.6	9.3	11.0	11.8	13.2	14.5	15.6	16.5
TC/01		9.7	10.9	14.9	15.7	15.6	5.9	8.9	9.5	9.9	10.1	5.8	6.6	7.4	10.4	11.3	14.7	15.6	16.2	16.7	16.7
TC/02		11.5	12.9	17.7	18.9	18.8	7.2	11.1	11.9	12.5	12.7	7.2	8.2	9.3	13.2	14.3	18.5	19.6	20.5	21.0	21.0
TC/03		14.9	16.6	22.4	23.6	23.4	9.6	14.5	15.5	16.1	16.3	9.6	10.9	12.2	16.9	18.2	23.8	25.1	26.1	26.6	26.4
TU/00	35	0.40	0.44	0.57	0.61	0.62	0.28	0.41	0.44	0.46	0.47	0.24	0.27	0.30	0.40	0.44	0.56	0.61	0.64	0.66	0.65
TU/01		0.46	0.53	0.78	0.88	0.91	0.32	0.56	0.62	0.66	0.70	0.26	0.32	0.37	0.57	0.64	0.77	0.84	0.90	0.94	0.98
TU/02		0.53	0.62	1.0	1.2	1.3	0.37	0.72	0.83	0.94	1.0	0.3	0.4	0.4	0.8	0.9	1.0	1.1	1.3	1.4	1.5
TU/03		0.75	0.88	1.4	1.7	1.8	0.52	1.0	1.2	1.3	1.4	0.4	0.5	0.6	1.1	1.3	1.4	1.6	1.8	1.9	2.1
TU/04		1.1	1.3	2.1	2.6	2.8	0.76	1.5	1.7	1.9	2.1	0.6	0.8	0.9	1.6	1.9	2.1	2.4	2.6	2.9	3.1
TU/05		1.5	1.7	2.8	3.4	3.7	1.0	2.0	2.3	2.6	2.9	0.9	1.0	1.2	2.1	2.6	2.8	3.1	3.5	3.8	4.2
TU/06		2.2	2.6	4.2	5.1	5.5	1.5	3.0	3.5	3.9	4.3	1.3	1.5	1.8	3.2	3.9	4.2	4.7	5.2	5.8	6.3
TU/07		2.9	3.4	5.7	6.9	7.4	2.1	4.0	4.6	5.2	5.8	1.7	2.1	2.4	4.3	5.2	5.6	6.3	7.0	7.7	8.4
TU/08		4.4	5.1	8.5	10.2	11.0	3.1	6.1	6.9	7.8	8.5	2.6	3.1	3.7	6.3	7.7	8.4	9.4	10.5	11.5	12.4
TU/09		6.5	7.5	12.6	15.3	16.4	4.5	8.9	10.2	11.5	12.8	3.7	4.5	5.3	9.4	11.6	12.4	13.9	15.5	17.1	18.6
TC/01		10.3	11.5	16.3	17.9	18.3	6.2	9.7	10.5	11.2	11.7	5.4	6.3	7.2	10.6	11.9	15.4	16.5	17.4	18.2	18.8
TC/02		12.2	13.7	19.5	21.5	22.1	7.7	12.2	13.2	14.1	14.8	6.9	7.9	9.1	13.4	15.1	19.4	20.9	22.1	23.1	23.8
TC/03		15.9	17.8	24.7	26.9	27.5	10.2	15.9	17.1	18.2	19.0	9.3	10.6	12.0	17.3	19.2	25.1	26.8	28.2	29.3	29.9
TU/00	45	0.40	0.45	0.60	0.65	0.67	0.28	0.43	0.46	0.48	0.51	0.21	0.24	0.27	0.38	0.43	0.56	0.61	0.65	0.67	0.68
TU/01		0.47	0.54	0.82	0.94	0.98	0.32	0.58	0.64	0.70	0.75	0.23	0.28	0.34	0.54	0.6	0.77	0.84	0.91	0.96	1.0
TU/02		0.54	0.63	1.1	1.3	1.5	0.37	0.75	0.87	0.99	1.1	0.3	0.3	0.4	0.7	0.9	1.0	1.2	1.3	1.4	1.6
TU/03		0.75	0.89	1.5	1.8	2.0	0.52	1.1	1.2	1.4	1.5	0.4	0.4	0.5	1.0	1.3	1.4	1.6	1.8	2.0	2.2
TU/04		1.1	1.3	2.2	2.8	3.0	0.77	1.6	1.8	2.1	2.3	0.5	0.7	0.8	1.5	1.9	2.1	2.4	2.7	3.0	3.3
TU/05		1.5	1.7	3.0	3.7	4.0	1.0	2.1	2.4	2.8	3.1	0.7	0.9	1.1	2.0	2.6	2.8	3.2	3.6	4.0	4.4
TU/06		2.2	2.6	4.5	5.5	6.1	1.5	3.1	3.6	4.1	4.7	1.1	1.4	1.7	3.0	3.8	4.2	4.8	5.4	6.0	6.6
TU/07		3.0	3.5	6.0	7.4	8.1	2.1	4.2	4.9	5.5	6.2	1.5	1.8	2.2	4.1	5.1	5.6	6.4	7.2	8.0	8.9
TU/08		4.5	5.3	9.0	11.1	12.1	3.1	6.3	7.3	8.3	9.3	2.3	2.8	3.3	6.1	7.6	8.4	9.6	10.7	11.9	13.1
TU/09		6.6	7.7	13.3	16.5	18.0	4.5	9.3	10.8	12.3	13.8	3.1	3.9	4.8	9.0	11.4	12.4	14.1	15.9	17.8	19.6
TC/01		10.5	11.9	17.2	19.3	20.1	6.3	10.1	11.1	11.9	12.7	4.8	5.7	6.6	10.2	11.7	15.6	16.8	17.9	18.9	19.8
TC/02		12.6	14.2	20.7	23.3	24.3	7.9	12.8	14.0	15.2	16.2	6.2	7.2	8.4	12.9	14.9	19.8	21.4	22.8	24.1	25.2
TC/03		16.6	18.7	26.4	29.3	30.3	10.6	16.8	18.2	19.6	20.7	8.5	9.9	11.3	16.8	19.0	25.8	27.6	29.3	30.7	31.7
TU/00	55	0.41	0.45	0.62	0.68	0.70	0.27	0.43	0.46	0.49	0.52	0.17	0.20	0.24	0.35	0.39	0.54	0.59	0.63	0.66	0.67
TU/01		0.47	0.54	0.84	0.98	1.0	0.31	0.58	0.65	0.71	0.77	0.18	0.23	0.28	0.48	0.6	0.75	0.82	0.89	0.95	1.0
TU/02		0.53	0.63	1.1	1.4	1.6	0.37	0.75	0.87	1.0	1.2	0.20	0.3	0.3	0.7	0.9	1.00	1.1	1.3	1.5	1.6
TU/03		0.73	0.88	1.6	1.9	2.1	0.50	1.1	1.3	1.4	1.6	0.2	0.3	0.4	0.9	1.2	1.4	1.6	1.8	2.0	2.2
TU/04		1.1	1.3	2.3	2.9	3.2	0.75	1.6	1.8	2.1	2.4	0.4	0.5	0.6	1.4	1.8	2.1	2.4	2.7	3.0	3.3
TU/05		1.5	1.7	3.1	3.8	4.3	0.96	2.1	2.4	2.8	3.2	0.5	0.7	0.9	1.8	2.4	2.7	3.1	3.6	4.0	4.5
TU/06		2.2	2.6	4.7	5.8	6.4	1.4	3.2	3.7	4.3	4.9	0.9	1.1	1.4	2.8	3.6	4.2	4.8	5.4	6.1	6.8
TU/07		2.9	3.5	6.2	7.7	8.5	2.0	4.2	4.9	5.7	6.4	1.1	1.5	1.8	3.7	4.8	5.4	6.2	7.1	8.0	9.0
TU/08		4.4	5.2	9.2	11.5	12.7	3.0	6.3	7.4	8.5	9.6	1.8	2.2	2.8	5.5	7.1	8.2	9.4	10.7	12.0	13.3
TU/09		6.5	7.7	13.7	17.2	19.0	4.3	9.3	10.9	12.5	14.3	2.2	3.0	3.8	8.1	10.5	12.1	13.9	15.8	17.8	19.9
TC/01		10.6	12.1	17.8	20.2	21.2	6.2	10.3	11.3	12.3	13.2	3.8	4.7	5.6	9.3	10.9	15.3	16.6	17.9	19.0	20.1
TC/02		12.8	14.5	21.6	24.5	25.8	7.9	13.1	14.4	15.7	16.8	5.1	6.1	7.3	11.9	14.0	19.6	21.3	22.9	24.3	25.6
TC/03		17.1	19.3	27.6	30.9	32.2	10.7	17.2	18.8	20.3	21.7	7.2	8.6	10.0	15.6	17.9	25.8	27.8	29.6	31.1	32.4

7) Condensing temperature at bubble point.

Capacities

R410A

Valve type/ Orifice	Cond. temp. ⁷⁾ [°C]	Capacity in [kW]				
		Evaporating temp. [°C]				
		-10	-5	0	5	10
TU / 00	25	0.77	0.78	0.78	0.76	0.71
TU / 01		1.11	1.15	1.17	1.16	1.11
TU / 02		1.60	1.7	1.8	1.9	1.9
TU / 03		2.2	2.4	2.6	2.6	2.6
TU / 04		3.3	3.6	3.9	4.0	4.0
TU / 05		4.4	4.8	5.1	5.3	5.3
TU / 06		6.7	7.3	7.8	8.1	8.0
TU / 07		8.9	9.7	10.3	10.7	10.7
TU / 08		13.3	14.5	15.3	15.8	15.7
TU / 09	19.9	21.6	23.0	23.9	23.7	
TC / 01	17.3	18.2	18.7	18.7	17.9	
TC / 02	21.9	23.0	23.7	23.7	22.8	
TC / 03	28.4	29.6	30.3	30.2	28.8	
TU / 00	35	0.80	0.83	0.84	0.85	0.83
TU / 01		1.16	1.22	1.27	1.30	1.30
TU / 02		1.7	1.9	2.0	2.2	2.3
TU / 03		2.4	2.6	2.8	3.0	3.1
TU / 04		3.6	3.9	4.3	4.6	4.8
TU / 05		4.7	5.2	5.7	6.1	6.3
TU / 06		7.1	7.9	8.6	9.2	9.7
TU / 07		9.5	10.5	11.4	12.2	12.9
TU / 08		14.2	15.6	16.9	18.0	18.8
TU / 09	21.1	23.3	25.4	27.1	28.5	
TC / 01	18.5	19.7	20.7	21.3	21.6	
TC / 02	23.5	25.0	26.2	27.1	27.5	
TC / 03	30.4	32.2	33.6	34.5	34.8	
TU / 00	45	0.80	0.83	0.86	0.87	0.87
TU / 01		1.17	1.23	1.29	1.34	1.4
TU / 02		1.7	1.9	2.1	2.3	2.4
TU / 03		2.4	2.7	2.9	3.1	3.3
TU / 04		3.6	4.0	4.4	4.8	5.1
TU / 05		4.8	5.3	5.8	6.3	6.8
TU / 06		7.2	8.0	8.9	9.6	10.3
TU / 07		9.6	10.7	11.7	12.8	13.7
TU / 08		14.3	15.9	17.4	18.8	20.1
TU / 09	21.3	23.7	26.1	28.3	30.3	
TC / 01	18.8	20.1	21.4	22.4	23.1	
TC / 02	23.9	25.6	27.2	28.5	29.5	
TC / 03	31.1	33.1	34.9	36.3	37.2	
TU / 00	55	0.77	0.80	0.83	0.85	0.86
TU / 01		1.12	1.19	1.26	1.31	1.3
TU / 02		1.67	1.9	2.1	2.2	2.4
TU / 03		2.3	2.6	2.9	3.1	3.3
TU / 04		3.4	3.9	4.3	4.7	5.1
TU / 05		4.7	5.2	5.7	6.3	6.8
TU / 06		6.9	7.8	8.7	9.5	10.4
TU / 07		9.2	10.4	11.5	12.6	13.7
TU / 08		13.8	15.5	17.1	18.6	20.1
TU / 09	20.5	23.0	25.5	28.0	30.3	
TC / 01	18.3	19.7	21.0	22.2	23.2	
TC / 02	23.3	25.2	26.9	28.4	29.7	
TC / 03	30.5	32.6	34.5	36.1	37.4	

When the subcooling $\neq 4$ K then:

1. Table value x Factor = Plant capacity
2. Plant capacity / Factor = Table value

Example:

$$Q_{nom} = 10 \text{ kW}$$

$$t_e = -10^\circ\text{C}$$

$$t_c = 55^\circ\text{C}$$

$$Dt_{sub} = 25 \text{ K}$$

Selection:

1. TC, Orifice 01 = 10.3 kW x 1.25 = 12.9 kW Valve too large

Right selection:

2. 10 kW / 1.25 = 8 kW TU, Orifice 09

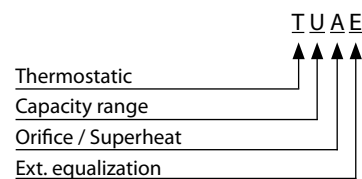

	Orifice / Superheat	
	Exchangeable	Adjustable
A	Yes	YES
B	NO	YES
C	NO	NO

- N = -40°C +10°C
 NM = -40°C -5°C with MOP
 NL = -40°C -15°C with MOP
 B = -60°C -25°C with MOP

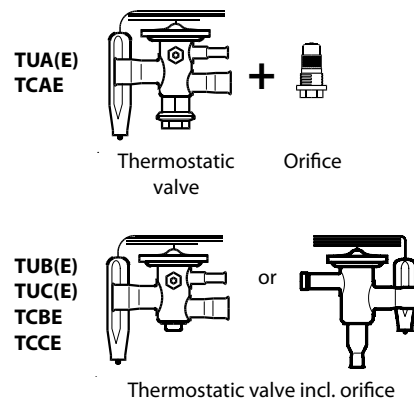

Valve types TUB(E)/TUC(E) and TCBE/TCCE can be replaced by TUA(E) and TCAE types

Correction factor

Refrigerant	Subcooling [K]										
	2	4	10	15	20	25	30	35	40	45	50
R22	0.98	1	1.06	1.11	1.15	1.20	1.25	1.30	1.35	1.39	1.44
R134a	0.98	1	1.08	1.13	1.19	1.25	1.31	1.37	1.42	1.48	1.54
R404A / R507	0.96	1	1.10	1.20	1.29	1.37	1.46	1.54	1.63	1.70	1.78
R407C	0.97	1	1.08	1.14	1.21	1.27	1.33	1.39	1.45	1.51	1.57
R410A	0.97	1	1.08	1.15	1.21	1.27	1.33	1.39	1.45	1.50	1.56

The complete Danfoss program of thermostatic expansion valves:

Type	Rated capacities in kW for range N					Connections
	R22	R134a	R404A / R507	R407C	R410A	
T 2 and TE 2 ¹⁾	0.5 - 15.5	0.4 - 10.5	0.38 - 9.1	0.5 - 16.7	-	Flare x flare and flare x solder Solder x solder (solder adaptor)
TUA and TUAE ¹⁾	0.6 - 16	0.45 - 12	0.45 - 12	0.63 - 17	1.3 - 26	Solder Bi-metal (stainless steel / copper)
TUB and TUBE ²⁾	0.9 - 16	0.7 - 12	0.7 - 12	0.92 - 17	1.3 - 26	Solder Bi-metal (stainless steel / copper)
TCAE ¹⁾ and TCBE ²⁾	17.5 - 26.5	12 - 18	13.5 - 20	19.0 - 28.5	23 - 34	Solder Bi-metal (stainless steel / copper)
TRE 10 - TRE 80 ²⁾	28 - 245	18 - 196	21 - 187	28 - 245	28 - 350	Solder Bi-metal (stainless steel / copper)
TE 5 - TE 55 ¹⁾	19.7 - 356	12.9 - 220	13 - 197	21.3 - 385	-	Flare / solder /solder flanges
PHT ¹⁾	105 - 1890	55 - 1083	99 - 1623	117 - 2020	-	Solder or weld flanges
TDE and TDEB ²⁾	10.5 - 140	5.7 - 79	8.4 - 109	10.5 - 140	-	Solder (copper)

¹⁾ Interchangeable orifice.

²⁾ Fixed orifice.

Thermostatic expansion valves parts program:

T 2 and TE 2

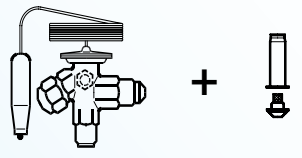

Thermostatic valve + Orifice



TUA/TUAE and TCAE

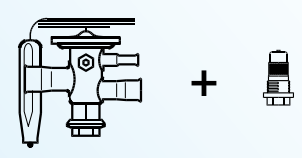

Thermostatic valve + Orifice

TE 5 - TE 55

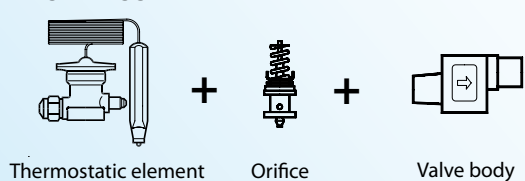

Thermostatic element + Orifice + Valve body

PHT

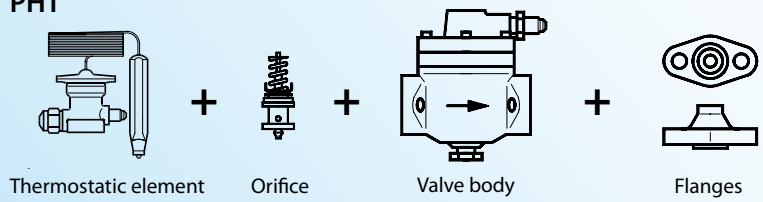

Thermostatic element + Orifice + Valve body + Flanges



PHT: The parts programme make flexibility

PHT thermostatic expansion valves regulate the injection of refrigerant liquid into evaporators. Injection is controlled by the refrigerant superheat. Therefore the valves are especially suitable for liquid injection in "dry" evaporators where the superheat at the evaporator outlet is proportional to the evaporator load.

Features

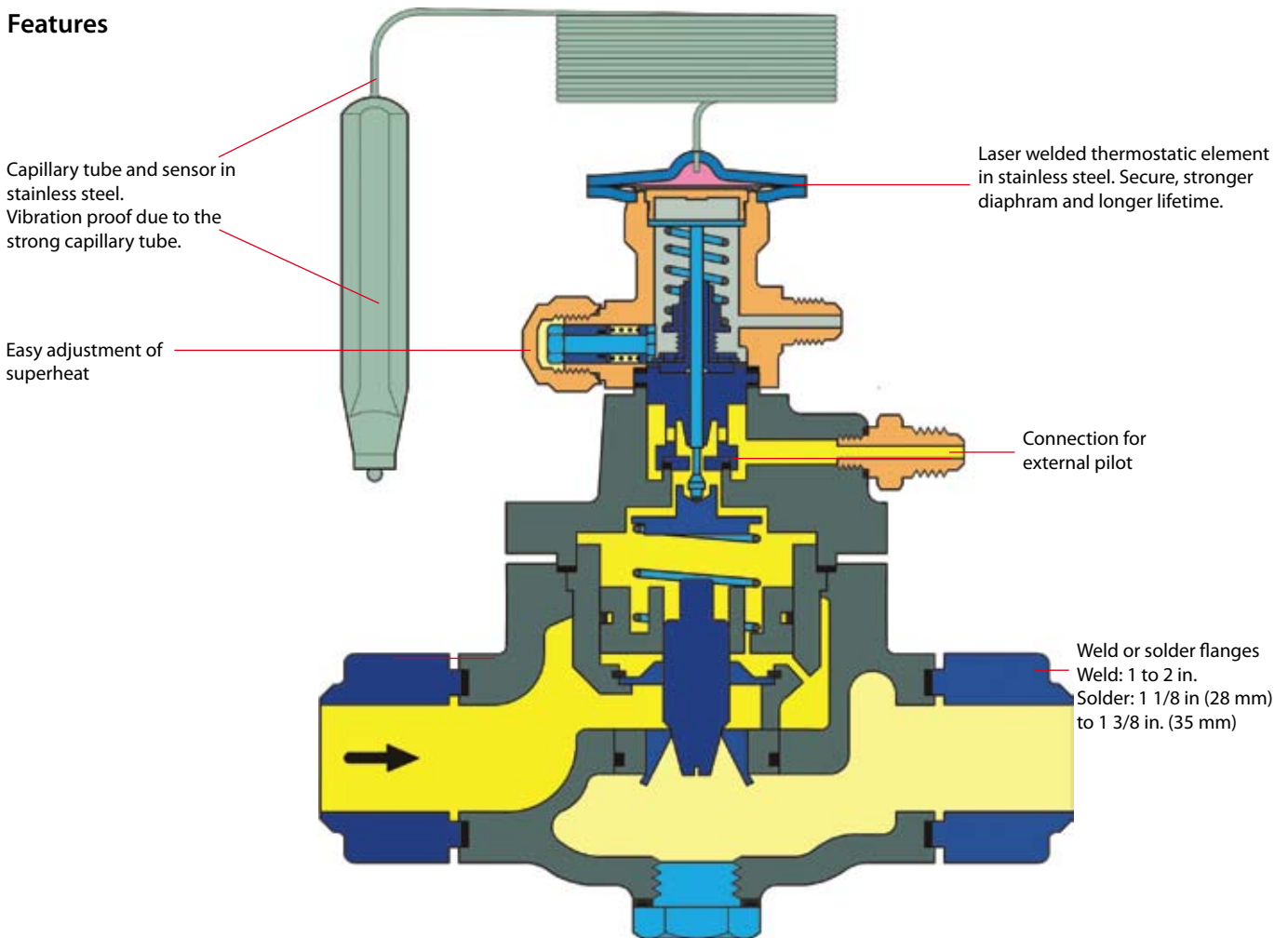

Applications	Advantages	Facts
<ul style="list-style-type: none"> Traditional refrigeration and freezing applications Water coolers and air conditioning 	<ul style="list-style-type: none"> <i>Interchangeable orifice assembly</i> <ul style="list-style-type: none"> easier stocking easy capacity matching better service. <i>Very tight main orifice</i> Also used as solenoid valve (not PHT 300) <i>Superheat</i> Static superheat SS can be adjusted with setting spindle (4). 	<ul style="list-style-type: none"> <i>Permissible working pressure</i> <ul style="list-style-type: none"> PHT 85 and 125: PS / MWP = 28 bar PHT 300: PS / MWP = 20 bar <i>Rated capacities from 105 to 1890 kW</i> (30 to 540 TR) for R22 <i>Can be supplied with MOP</i> (Max. Operating Pressure) Protects the compressor motor against excessive evaporating pressure <i>Range: -40 to +50°C</i>

Technical data and ordering

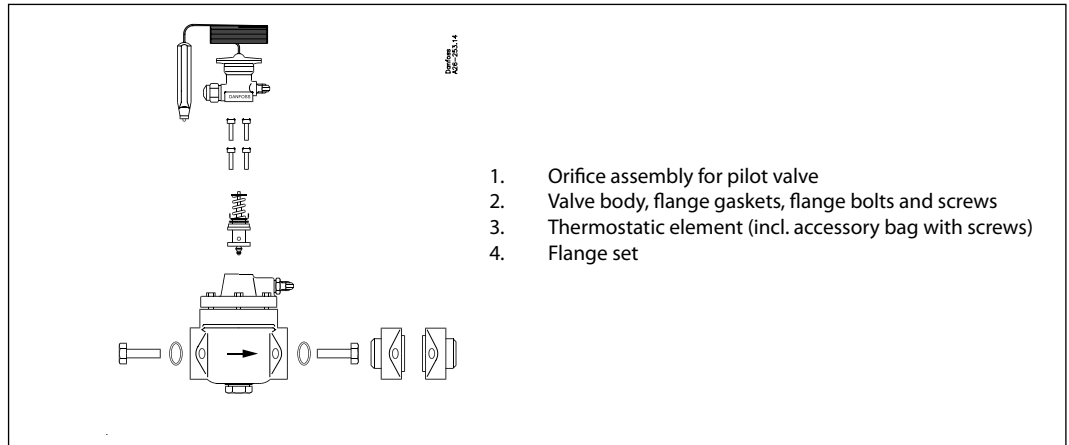
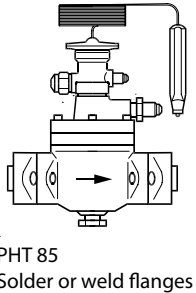

1. Pilot orifice assembly

Type	Code no.
PHT	067B2090

2. Valve body, flange gaskets, flange bolts and screws

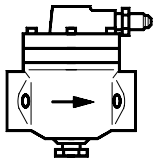

Type	Orifice no.	Rated capacity ²⁾ R22		Rated capacity ¹⁾ R134a				Code no.
		Range N: -40 to +10°C		Range N: -40 to +10°C		Range A: +10 to +50°C		
		TR	kW	TR	kW	TR	kW	
PHT 85	1	30	105	16	55	20	69	026H1160
PHT 85	2	50	175	26	92	33	114	026H1161
PHT 85	3	80	280	39	138	52	182	026H1162
PHT 85	4	130	455	59	208	72	273	026H1163
PHT 125	1	225	790	125	438	156	545	026H1164
PHT 300	1	325	1140	178	622	221	773	026H0165
PHT 300	2	540	1890	309	1083	351	1227	026H0166

¹⁾ A PHT 85 with orifice no. 5 and a capacity of +5 → +10% compared to orifice no. 4 can be ordered. The code no. is 026H1187.

²⁾ The rated capacity for range N is based on evaporating temperature $t_e = +5^\circ\text{C}$, condensing temperature $t_c = +32^\circ\text{C}$, and refrigerant liquid temperature ahead of valve $t_l = +28^\circ\text{C}$.

The rated capacity for range A is based on evaporating temperature $t_e = +5^\circ\text{C}$, condensing temperature $t_c = +42^\circ\text{C}$, and refrigerant liquid temperature ahead of valve $t_l = +38^\circ\text{C}$.

See following pages for extended capacity tables.

3. Thermostatic element (incl. accessory bag)

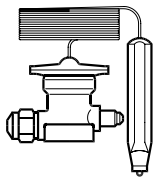

Range	Refrigerant	Code no.	
		3 m capillary tube	5 m capillary tube
-40 to +10°C	R22	067B3303	067B3304
	R22, MOP 100 psig	067B3300	067B3306
	R407C	067B3314	067B3341
	R407C, MOP 95 psig	067B3311	
	R134a	067B3310	067B3315
	R134a, MOP 55 psig	067B3316	067B3317
	R404A / R507		067B3319
+10 to +50°C	R134a		067B3318

4. Flange set



Valve flange	Flange type	Weld flanges		Solder flanges			
		in.	Code no.	in.	Code no.	mm	Code no.
PHT 85	2	1	027N1025				
PHT 85	2			1 ¹ / ₈	027L1029	28	027L1028
PHT 85	2			1 ³ / ₈	027L1035	35	027L1035
PHT 125	3 A	1 ¹ / ₄	027N1032				
PHT 300	4 A	1 ¹ / ₂	027N1040				
PHT 300	4 A	2	027N1050				

Technical data and ordering

Valve type / Orifice	Cond. temp. [°C]	R22					R134a					R404A / R507					R407C				
		Capacity in [kW] Evaporating temp. [°C]					Capacity in [kW] Evaporating temp. [°C]					Capacity in [kW] Evaporating temp. [°C]					Capacity in [kW] Evaporating temp. [°C]				
		-35	-30	-10	0	5	-30	-10	-5	0	5	-40	-35	-30	-10	0	-10	-5	0	5	10
PHT85-1	25	42	49	79	90	93	17.8	38	43	48	51	34	40	47	76	87	85	94	101	108	111
PHT85-2		73	85	133	149	151	32	67	76	83	87	59	70	81	124	139	143	156	167	174	177
PHT85-3		110	128	205	234	240	47	101	114	125	132	90	105	122	193	220	221	242	262	277	285
PHT85-4		109	128	292	377	403	52	108	128	150	172	96	112	139	300	371	317	372	422	464	492
PHT125-1		357	407	609	653	642	160	322	360	391	411	283	324	371	562	614	655	700	730	739	719
PHT300-1		483	553	869	994	1025	224	445	500	547	580	391	454	522	809	921	930	1019	1099	1164	1203
PHT300-2		864	980	1472	1642	1671	411	788	877	952	1002	693	797	906	1334	1477	1573	1701	1811	1891	1926
PHT85-1	35	45	53	89	106	113	19.6	43	50	56	62	33	39	46	79	95	91	101	111	121	129
PHT85-2		79	92	149	173	181	35	75	86	96	104	57	68	80	129	150	153	168	182	194	203
PHT85-3		119	139	229	271	288	51	113	130	146	160	86	103	120	200	238	235	260	285	308	327
PHT85-4		121	144	331	438	484	58	125	150	181	215	93	110	139	314	402	341	402	461	515	560
PHT125-1		379	436	680	760	773	174	357	404	448	486	271	315	365	579	654	697	756	804	834	843
PHT300-1		521	599	962	1135	1205	245	495	563	628	686	380	445	516	833	985	982	1085	1185	1277	1356
PHT300-2		935	1064	1628	1867	1953	449	874	983	1085	1173	675	783	898	1373	1575	1660	1809	1946	2065	2158
PHT85-1	45	47	56	95	116	125	21	46	53	61	68	29	35	43	77	95	93	104	116	127	137
PHT85-2		83	97	159	188	201	36	80	92	104	115	51	62	74	127	151	155	172	188	202	214
PHT85-3		125	146	245	295	318	53	120	139	158	177	76	93	111	195	239	238	266	294	320	345
PHT85-4		129	155	357	478	532	61	135	164	199	241	80	99	128	310	404	350	413	476	535	589
PHT125-1		384	448	729	838	870	179	376	429	481	529	240	285	338	563	651	712	783	843	890	919
PHT300-1		548	631	1024	1224	1316	255	524	600	675	748	341	406	478	807	978	995	1105	1214	1318	1416
PHT300-2		985	1122	1730	2008	2124	469	922	1044	1161	1270	613	723	839	1334	1564	1681	1839	1988	2124	2241
PHT85-1	55	48	57	99	122	133	21	47	55	63	72	22	28	36	71	90	91	103	115	127	139
PHT85-2		84	99	166	198	212	36	82	95	108	121	40	51	63	117	143	153	170	186	201	215
PHT85-3		127	149	253	308	335	51	122	142	163	183	59	75	93	179	225	233	262	290	319	346
PHT85-4		134	162	373	500	560	61	138	169	208	254	59	77	106	287	383	345	409	473	534	589
PHT125-1		373	443	758	891	940	176	381	438	494	547	189	236	289	520	613	702	781	852	912	956
PHT300-1		561	647	1057	1273	1376	253	532	612	694	774	275	338	408	736	912	973	1085	1196	1306	1411
PHT300-2		1011	1154	1785	2083	2213	468	936	1063	1189	1308	508	616	731	1226	1465	1642	1801	1952	2093	2218

Correction factor

Refrigerant	Subcooling [K]										
	2	4	10	15	20	25	30	35	40	45	50
R22	0.98	1	1.06	1.11	1.15	1.2	1.25	1.3	1.35	1.39	1.44
R134a	0.98	1	1.08	1.13	1.19	1.25	1.31	1.37	1.42	1.48	1.54
R404A/507	0.96	1	1.1	1.2	1.29	1.37	1.46	1.54	1.63	1.7	1.78
R407C	0.97	1	1.08	1.14	1.21	1.27	1.33	1.39	1.45	1.51	1.57

When the subcooling ≠ 4 K then:
 1. Table value x Factor = Plant capacity
 2. Plant capacity : Factor = Table value

Example:
 Qo = 10 kW
 to = -10°C
 tc = 45°C
 Δtu = 25 K

Selection:
 1. PHT 85, Orifice 04 = 135 kW x 1,25 = 168,75 kW ! Valve too large
Right selection:
 2. 130 kW : 1,25 = 104 kW → PHT, Orifice 03 ✓

Thermostatic expansion valves parts program:

T 2 and TE 2

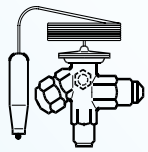

+



Thermostatic valve

Orifice

TUA/TUAE and TCAE

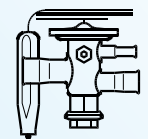

+



Thermostatic valve

Orifice

TE 5 - TE 55

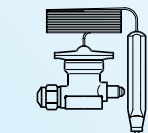

+



+

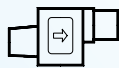

Thermostatic element

Orifice

Valve body

PHT

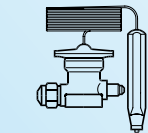

+



+

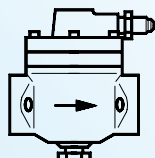

+



Thermostatic element

Orifice

Valve body

Flanges





AKV : Precise injection in the evaporator

AKV are electrically operated expansion valves designed for refrigerating plant. The AKV valves are normally operated by a controller from the Danfoss ADAP-KOOL range. The valves are operated with pulsating regulation which means that the opening degree is controlled by demand (adaptive regulation).

Features

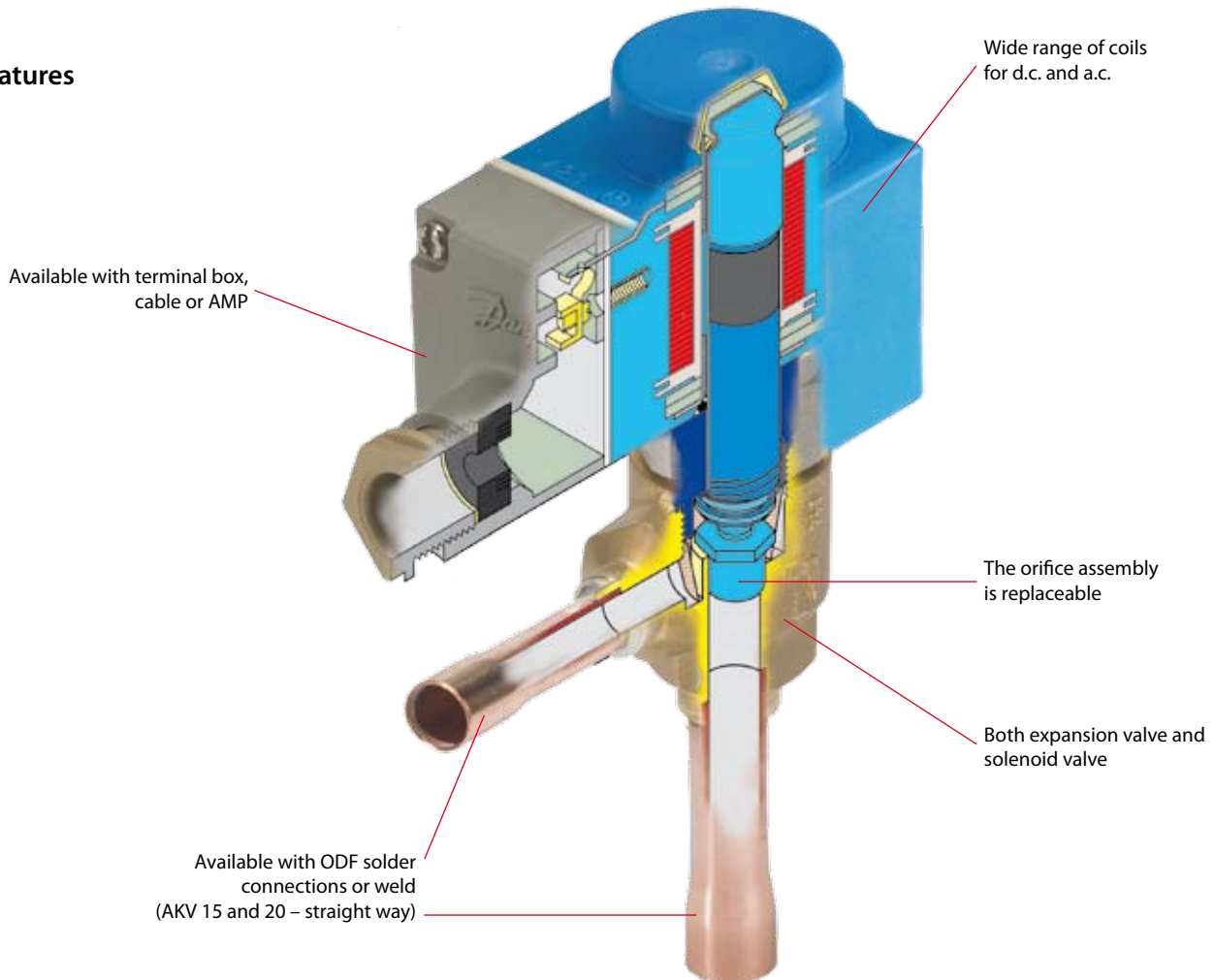

Applications	Advantages	Facts
<ul style="list-style-type: none"> Traditional refrigeration Cold rooms Water chillers 	<ul style="list-style-type: none"> The AKV valves are supplied as a component programme, as follows: <ul style="list-style-type: none"> Separate valve incl. exchangeable orifice Separate coil Flexibility in MOP setting (the regulator closes when the pressure in the evaporator falls below the set value). The valve requires no adjustment 	<ul style="list-style-type: none"> The AKV 10 valves cover a capacity range from 1 kW to 16 kW (R22) and are divided into 7 capacity ranges. The AKV 15 valves cover a capacity range from 25 kW to 100 kW (R22) and are divided into 4 capacity ranges. The AKV 20 valves cover a capacity range from 100 kW to 630 kW (R22) and are divided into 5 capacity ranges. The AKV valves can be used for HCFC and HFC, R744 refrigerants.

Technical data and ordering

AKV 10

Valve type	Rated capacity kW ¹⁾				k _v value m ³ /h	Connections			
	R22	R134a	R404A/R507	R407C		Solder ODF			
						Inlet × outlet in.	Code no.	Inlet × outlet mm	Code no.
AKV 10-1	1.0	0.9	0.8	1.1	0.010	3/8 × 1/2	068F1161	10 × 12	068F1162
AKV 10-2	1.6	1.4	1.3	1.7	0.017	3/8 × 1/2	068F1164	10 × 12	068F1165
AKV 10-3	2.6	2.1	2.0	2.5	0.025	3/8 × 1/2	068F1167	10 × 12	068F1168
AKV 10-4	4.1	3.4	3.1	4.0	0.046	3/8 × 1/2	068F1170	10 × 12	068F1171
AKV 10-5	6.4	5.3	4.9	6.4	0.064	3/8 × 1/2	068F1173	10 × 12	068F1174
AKV 10-6	10.2	8.5	7.8	10.1	0.114	3/8 × 1/2	068F1176	10 × 12	068F1177
AKV 10-7	16.3	13.5	12.5	17.0	0.209	1/2 × 3/8	068F1179	12 × 16	068F1180

AKV 15

AKV 15-1	25.5	21.2	19.6	25.2	0.25	3/4 × 3/4	068F5000	18 × 18	068F5001
AKV 15-2	40.8	33.8	31.4	40.4	0.40	3/4 × 3/4	068F5005	18 × 18	068F5006
AKV 15-3	64.3	53.3	49.4	63.7	0.63	3/8 × 3/8	068F5010	22 × 22	068F5010
AKV 15-4	102	84.6	78.3	101	1.0	1 1/8 × 1 1/8	068F5015	28 × 28	068F5016

AKV 20

Valve type	Rated capacity kW ¹⁾				k _v value m ³ /h	Connections					
	R22	R134a	R404A/R507	R407C		Solder ODF			Weld		
						Inlet × outlet in.	Code no.	Inlet × outlet mm	Code no.	Inlet × outlet in.	Code no.
AKV 20-1	102	84.6	78.3	101	1.0	1 1/8 × 1 1/8	042H2020	35 × 35	042H2020	1 1/4 × 1 1/4	042H2021
AKV 20-2	163	135	125	170	1.6	1 1/8 × 1 1/8	042H2022	35 × 35	042H2022	1 1/4 × 1 1/4	042H2023
AKV 20-3	255	212	196	252	2.5	1 1/8 × 1 1/8	042H2024	42 × 42	042H2025	1 1/4 × 1 1/4	042H2026
AKV 20-4	408	338	314	404	4.0	2 1/8 × 2 1/8	042H2027	54 × 54	042H2027	1 1/2 × 1 1/2	042H2028
AKV 20-5	643	533	494	637	6.3	2 1/8 × 2 1/8	042H2029	54 × 54	042H2029	2 × 2	042H2030

¹⁾ Rated capacities are based on:
 Condensing temperature t_c = 32°C
 Liquid temperature t_l = 28°C
 Evaporating temperature t_e = 5°C

Technical data

Valve type	AKV 10	AKV 15	AKV 20
Tolerance of coil voltage	+10 / -15%	+10 / -15%	+10 / -15%
Enclosure to IEC 529	Max. IP 67	Max. IP 67	Max. IP 67
Working principle (Pulse-width modulation)	PWM	PWM	PWM
Recommended period of time	6 Seconds	6 Seconds	6 Seconds
Capacity (R22)	1 to 16 kW	25 to 100 kW	100 to 630 kW
Regulation range (Capacity range)	10 to 100%	10 to 100%	10 to 100%
Connection	Solder	Solder	Solder or weld
Evaporating temperature	- 60 to 60°C	- 50 to 60°C	- 40 to 60°C
Ambient temperature	- 50 to 50°C	- 40 to 50°C	- 40 to 50°C
Leak of valve seat	<0.02% of k _v -value	<0.02% of k _v -value	<0.02% of k _v -value
MOPD	18 bar	22 bar	18 bar
Filter, replaceable	Internal 100 µm	External 100 µm	External 100 µm
Max. working pressure	PS=42 barg	AKV 15-1,2,3 PS 42 barg AKV 15-4 PS 28 barg	28 barg

Technical data and ordering

Ordering

Coils for AKV valves



AKV	AKV	AKV	AKV	AKV	AKV
10-1	10-6	10-7	15-1	20-1	20-4
10-2			15-2	20-2	20-5
10-3			15-3	20-3	
10-4			15-4		
10-5					

D.C. coils	Code no.						
220 V d.c. 20 W, standard with terminal box	018F6851	+	+	+	+	+	+
100 V d.c. 18 W, special with terminal box with DIN plugs	018F6780	+	+	+	+	+	+
230 V d.c. 18 W, special with terminal box with DIN plugs	018F6781 ¹⁾ 018F6991 ¹⁾	+	+	+	+	+	+
230 V d.c. 18 W, special with 2.5 m cable with 4.0 m cable with 8.0 m cable	018F6288 ¹⁾ 018F6278 ¹⁾ 018F6279 ¹⁾	+	+	+	+	+	+

¹⁾ Recommended for commercial refrigeration plant

A.C. coils	Code no.						
240 V a.c. 10 W, 50 Hz with terminal box with DIN plugs	018F6702 018F6177	+	+	-	+	-	-
240 V a.c. 10 W, 60 Hz with terminal box with DIN plugs	018F6713 018F6188	+	+	-	+	-	-
240 V a.c. 12 W, 50 Hz with terminal box	018F6802	+	+	+	+	+	-
230 V a.c. 10 W, 50 Hz with terminal box with DIN-plugs	018F6701 018F6176	+	+	-	+	-	-
230 V a.c. 10 W, 60 Hz with terminal box with DIN-plugs	018F6714 018F6189	+	+	-	+	-	-
230 V a.c. 10 W, 50/60 Hz with terminal box with DIN-plugs	018F6732 018F6193	+	+	-	+	-	-
230 V a.c. 12 W, 50 Hz with terminal box	018F6801	+	+	-	+	+	-
230 V a.c. 12 W, 60 Hz with terminal box	018F6814	+	+	-	+	+	-
115 V a.c. 10 W, 50 Hz with terminal box with DIN-plugs	018F6711 018F6186	+	+	-	+	-	-
115 V a.c. 10 W, 60 Hz with terminal box with DIN-plugs	018F6710 018F6185	+	+	-	+	-	-
110 V a.c. 12 W, 50 Hz with terminal box	018F6811	+	+	-	+	+	-
110 V a.c. 12 W, 60 Hz with terminal box	018F6813	+	+	-	+	+	-
110 V a.c. 20 W, 50 Hz with terminal box	018Z6904	+	+	+	+	+	+
24 V a.c. 10 W, 50 Hz with terminal box with DIN-plugs	018F6707 018F6182	+	-	-	+	-	-
24 V a.c. 10 W, 60 Hz with terminal box with DIN-plugs	018F6715 018F6190	-	-	-	+	-	-
24 V a.c. 12 W, 50 Hz with terminal box	018F6807	+	-	-	+	+	+
24 V a.c. 12 W, 60 Hz with terminal box	018F6815	+	-	-	+	+	+
24 V a.c. 20 W, 50 Hz with terminal box	018F6901	+	+	+	+	+	+
24 V a.c. 20 W, 60 Hz with terminal box	018F6902	+	+	+	+	+	+

Application example

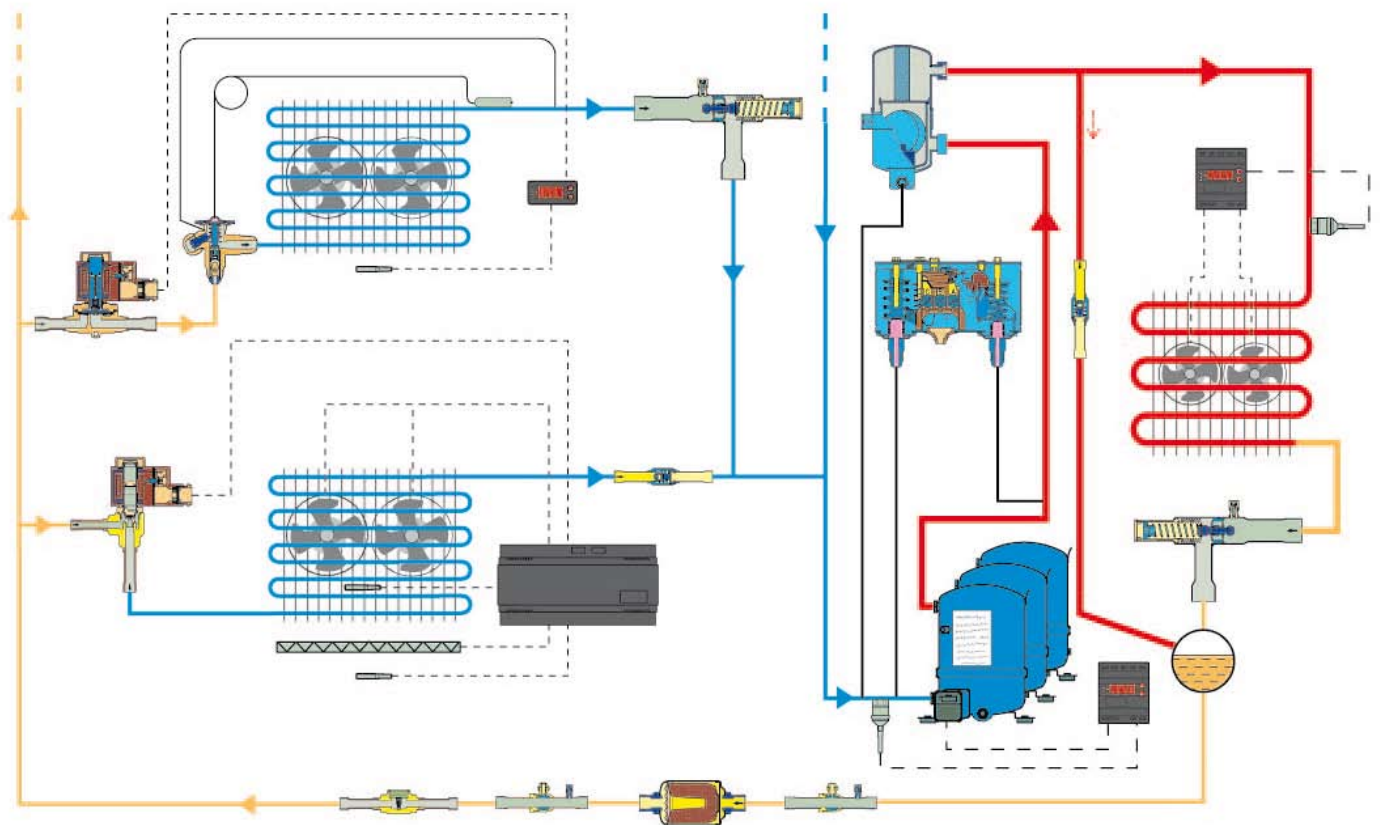



ETS : Precision and reliability

ETS is a series of electrically operated expansion valves for precise liquid injection in evaporators for air conditioning and refrigeration applications. The valve piston and linear positioning design is fully balanced, providing bi-flow feature as well as solenoid tight shut-off function in both flow directions. The ETS needs a current or voltage driver as a partner to be operated.

Features

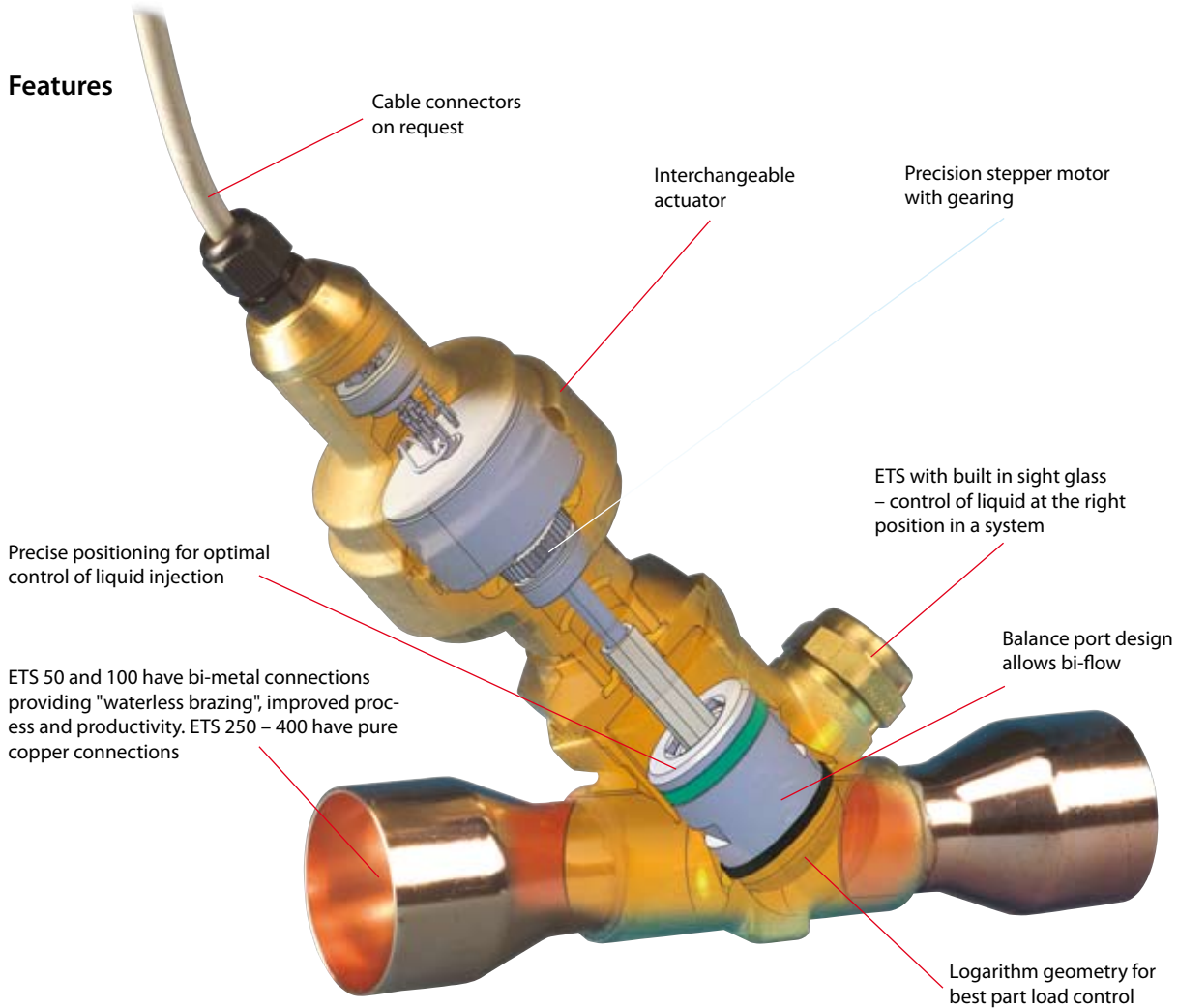

Applications	Advantages	Facts
<ul style="list-style-type: none"> Traditional refrigeration Air conditioning units 	<ul style="list-style-type: none"> For manual operation and service of ETS valves an AST-g service driver is available. Balanced design providing bi-flow operation as well as solenoid tight shut-off function in both flow directions at MOPD 33 bar (478.6 psig). 150 steps/sec. (constant voltage drive) 2625 - 3810 step depending on chopper model. 8.5 - 12.7 sec. with chopper current. 	<ul style="list-style-type: none"> Reference position: Overdriving against the full close position ETS 50 and 100 are designed for HFC/ HCFC conditions including R410A, providing 45.5 bar (659.9 psig) working pressure. ETS 250 and 400 are designed for HFC/ HCFC conditions, providing 34 bar (448 psig) working pressure. Solenoid tight shut-off function.

Technical data and ordering



Valve incl. actuator – Industrial pack (9 pcs.)

Type	Connection		Connection	
	ODF × ODF in	Code no. Industrial pack	ODF × ODF mm	Code no. Industrial pack
ETS 50B	$\frac{7}{8} \times \frac{7}{8}$	034G1000	22 × 22	034G1050
	$\frac{7}{8} \times 1\frac{1}{8}$	034G1001	22 × 28	034G1051
	$\frac{7}{8} \times 1\frac{3}{8}$	034G1002	22 × 35	034G1052
	$1\frac{1}{8} \times 1\frac{1}{8}$	034G1003	28 × 28	034G1053
	$1\frac{1}{8} \times 1\frac{3}{8}$	034G1004	28 × 35	034G1054
ETS 100B	$1\frac{1}{8} \times 1\frac{1}{8}$	034G0000	28 × 28	034G0050
	$1\frac{1}{8} \times 1\frac{3}{8}$	034G0001	28 × 35	034G0051
	$1\frac{1}{8} \times 1\frac{5}{8}$	034G0002	28 × 42	034G0052
	$1\frac{3}{8} \times 1\frac{3}{8}$	034G0003	35 × 35	034G0053
	$1\frac{3}{8} \times 1\frac{5}{8}$	034G0004	35 × 42	034G0054
	$1\frac{5}{8} \times 1\frac{5}{8}$	034G0005	42 × 42	034G0055

Valve incl. actuator and sight glass – Single pack

Type	Connection		
	ODF × ODF [in.]	ODF × ODF [mm]	Code no. Single pack
ETS 50B ²⁾	$\frac{7}{8} \times \frac{7}{8}$	22 × 22	034G1008
	$\frac{7}{8} \times 1\frac{1}{8}$	22 × 28	034G1005
	$1\frac{1}{8} \times 1\frac{1}{8}$	28 × 28	034G1006
ETS 100B	$1\frac{1}{8} \times 1\frac{1}{8}$	28 × 28	034G0007
	$1\frac{3}{8} \times 1\frac{3}{8}$	35 × 35	034G0008
ETS 250	$1\frac{1}{8} \times 1\frac{1}{8}$	28 × 28	034G2000
	$1\frac{3}{8} \times 1\frac{3}{8}$	35 × 35	034G2001
	$1\frac{5}{8} \times 1\frac{5}{8}$		034G2002
ETS 400	$1\frac{5}{8} \times 1\frac{5}{8}$		034G3000
	$2\frac{1}{8} \times 2\frac{1}{8}$	54 × 54	034G3001

Capacities

Type	Rated capacity ¹⁾									
	R410A		R407C		R22		R134a		R404A	
	kW	TR	kW	TR	kW	TR	kW	TR	kW	TR
ETS 50B ²⁾	262.3	75.7	240.5	69.1	215	62	170	48.9	161.4	46.3
ETS 100B	488.4	140.9	447.8	128.7	400.4	115.4	316.5	91.2	300.5	86.6
ETS 250	-	-	1212	349	1106	319	874	252	828	239
ETS 400	-	-	1933	556	1764	509	1394	402	1320	381

¹⁾ The rated capacity is based on:
 Evaporating temperature t_e : 5°C (40°F)
 Liquid temperature t_l : 28°C (82°F)
 Condensing temperature t_c : 32°C (90°F)
 Full stroke opening.

²⁾ ETS 25B is available upon request. Please contact Danfoss.
Note: ETS 25B is half the capacity of ETS 50B.

Valve operation

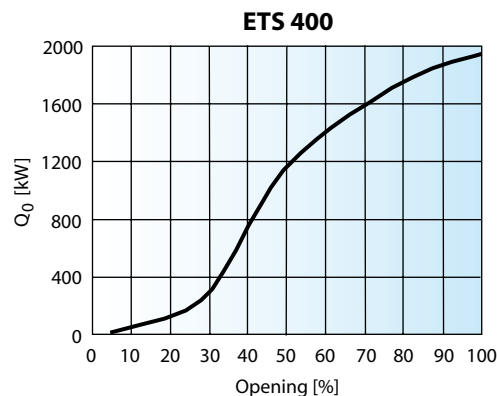
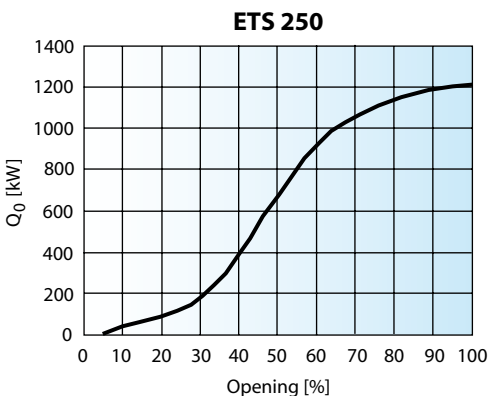
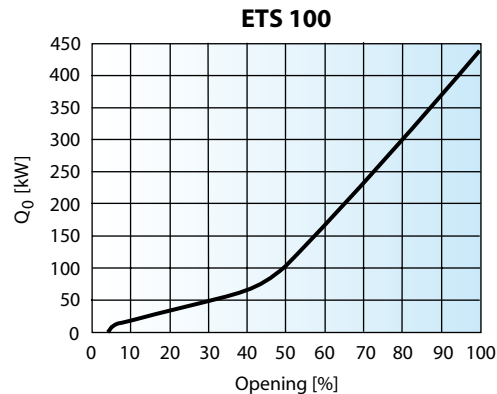
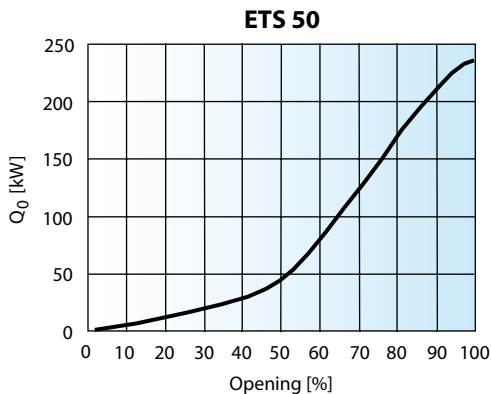

Capacity based on: R407C
 $t_e = 5^\circ\text{C}$ (40°F)
 $t_l = 28^\circ\text{C}$ (82°F)
 $t_c = 32^\circ\text{C}$ (90°F)

EVR: high reliability and flexibility

EVR valves are direct or servo-operated solenoid valves for liquid, suction and hot gas lines. They are suitable for condensing units and power packs in all refrigeration, freezing and air conditioning applications and are compatible with fluorinated refrigerants, including high-pressure refrigerants such as R410A (EVRH). The valves can be delivered as normally open and normally closed valves as well as with or without manual operation.

Features

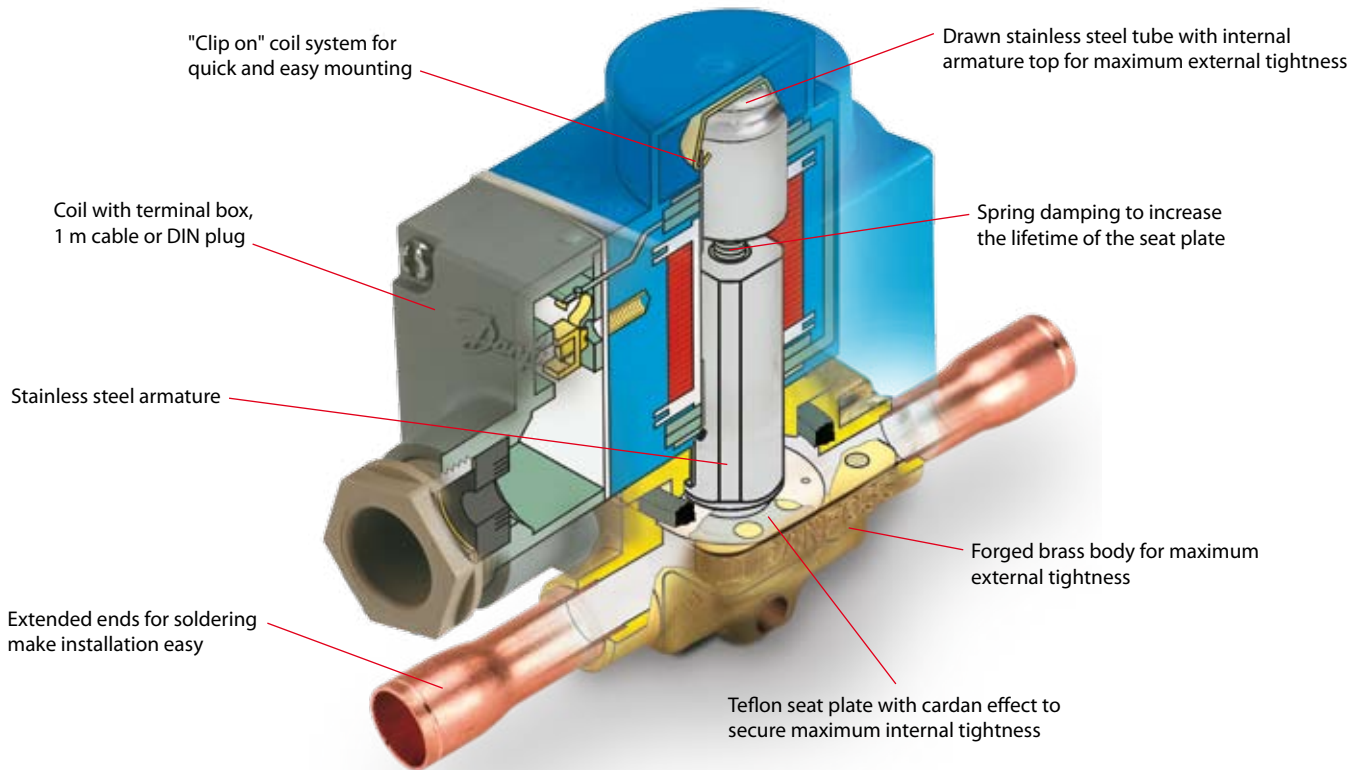

Applications	Advantages	Facts
<ul style="list-style-type: none"> Traditional refrigeration Heat pump systems Air conditioning units Liquid coolers Transport refrigeration 	<ul style="list-style-type: none"> Complete programme of valves and coils for every application. Wide range of coils for a.c. and d.c. Wide range of connection types and sizes. Normally open or normally closed. With or without manual operation. High reliability and durability due to maximum internal and external tightness. 	<ul style="list-style-type: none"> Can be used for all fluorinated refrigerants (CFC, HCFC and HFC). Temperature range: -40 to 105°C Max. working pressure (MWP) 32 bar (EVR 2-3, 45.2 bar / EVR 6-10, 35 bar / EVR 15 - 50, 32 bar). MOPD up to 25 bar with 12 W a.c. coil. 100% test of functionality, internal/ external leakage and electrical characteristics.

Technical data and ordering

Separate valve bodies, normally closed (NC)

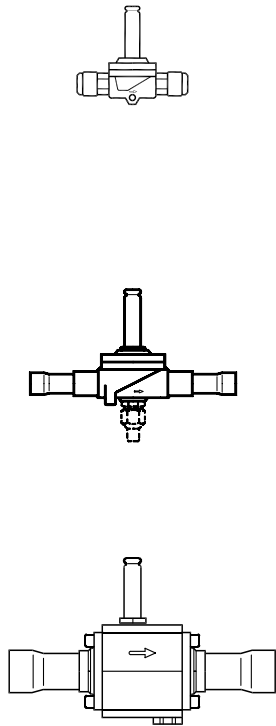

Type	Required coil type	Connection		Code no. ¹⁾					k, value ²⁾	
				Valve body without coil		Solder ODF				
		in.	mm	Flare in./mm	in.	mm	With manual operation	Without manual operation		
EVR 2	a.c.	¼	6	032F8056	032F1201	032F1202			0.16	
EVR 3	a.c./d.c.	¼	6	032F8107	032F1206	032F1207			0.27	
EVR 6		¾	10	032F8116	032F1204	032F1208				
		¾	10	032F8072	032F1212	032F1213			0.8	
EVR 10		½	12	032F8079	032F1209	032F1236				
		½	12	032F8095	032F1217	032F1218			1.9	
EVR 15		¾	16	032F8098	032F1214	032F1214				
		¾	16	032F8101	032F1228	032F1228			2.6	
		¾	16	032F8100			032F1227			
EVR 20		a.c.	¾	22		032F1225	032F1225			
			¾	22		032F1240	032F1240			
	¾		22				032F1254			
	1½	28		032F1244	032F1245					
	d.c.	¾	22		032F1264	032F1264				
¾		22				032F1274				
EVR 22	a.c.	1¾	35		032F3267	032F3267			6.0	
EVR 25	a.c./d.c.	1½					032F2200	032F2201	10.0	
			28				032F2205	032F2206		
		1¾	35				032F2207	032F2208		
EVR 32		1¾	35				042H1105	042H1106	16.0	
		1½					042H1103	042H1104		
			42				042H1107	042H1108		
EVR 40		1½					042H1109	042H1110	25.0	
			42				042H1113	042H1114		
		2½	54				042H1111	042H1112		

Mounting bracket

Mounting bracket	For mounting EVR 2, 3, 6 and 10	032F0197
------------------	---------------------------------	----------

Coils - alternating current a.c

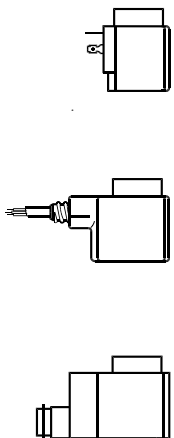

Type	Voltage V	Frequency Hz	Code no. ¹⁾				Appendix no.	Power consumption
			With 1 m 3-core cable IP 67	With terminal box IP 67	With DIN plugs and protective cap IP 20	With DIN plugs		
EVR 2 40 (NC)	12	50	018F6256	018F6706	018F6181		15	Holding: 10 W 21 VA Inrush: 44 VA
	24	50	018F6257	018F6707	018F6182	018F7358	16	
	42	50	018F6258	018F6708	018F6183		17	
	48	50	018F6259	018F6709	018F6184		18	
	115	50	018F6261	018F6711	018F6186	018F7361	22	
	220-230	50	018F6251	018F6701	018F6176	018F7351	31	
	240	50	018F6252	018F6702	018F6177	018F7352	33	
	380-400	50	018F6253	018F6703	018F6178		37	
	420	50	018F6254	018F6704	018F6179		38	
	24	60	018F6265	018F6715	018F6190		14	
	115	60	018F6260	018F6710	018F6185		20	
	220	60	018F6264	018F6714	018F6189		29	
	240	60	018F6263	018F6713	018F6188		30	
	110	50/60	018F6280	018F6730	018F6192	018F7360	21	
	220-230	50/60	018F6282	018F6732	018F6193	018F7363	32	

Terminal box with LED light indicator

Terminal box	With built-in light emitting indicator diode for solenoid valves	018Z0089
DIN socket		042N0156

¹⁾ Code numbers in bold are normally on stock and a shorter delivery time can therefore be expected.

²⁾ The k, value is the water flow in m³/h at a pressure drop across valve of 1 bar, $\rho = 1000 \text{ kg/m}^3$.



EVRA and EVRAT - Solenoid valves

EVRA is a direct or servo operated solenoid valve for liquid, suction and hot gas lines with ammonia or fluorinated refrigerants. EVRA valves can be supplied as complete valves or as components, i.e. valve body, flanges and coils. EVRAT has capacities similar to the EVRA but has the advantage of no opening pressure differential - it will open - and stay open, also when there is no flow through the valve.



Advantages and features

- EVRA and EVRAT valves can be used for all non-flammable refrigerants, including R 717, and non-corrosive gases/liquids - assuming seals of correct material are used
- EVRA and EVRAT valves uses a teflon gasket which ensures a very high tightness across valve seat
- EVRA valves has a low pressure drop
- EVRAT valves has a opening differential pressure of 0 (zero)
- The EVRA and EVRAT valves offers a wide range of flange connection dimensions in accordance with standards: DIN ANSI, SOC, SA and FPT
- The EVRA and EVRAT valve range can be used with the wide range of standard Danfoss coils
- Strainer type FA can be mounted directly on the valve body except for EVRA 32 and 40
- Certification: Please contact Danfoss for an updated list with type approvals for the products

Connections

There is a wide range of connection possibilities with EVRA 3 to 25 and EVRAT 10-20:

- Butt welding DIN (2448)
- Butt welding ANSI
(3/8 - 1½ in. B36.10 schedule 80, 2 in. B36.10 schedule 40)
- Socket welding ANSI (B 16.11)
- Solder connection DIN (2856)
- Solder connection ANSI (B 16.22)
- FPT internal thread, NPT (ANSI/ASME B 1.20.1)

EVRA 32 and 40 are supplied with integrated flanges for either:

- Welding DIN (2448) or
- Welding ANSI (B 36.10)

Technical data and code numbers

Technical data

Type	Opening differential pressure with standard coil Δp bar				Temperature of medium °C	Max. working pressure PB bar	kv-value m ³ /h
	Min.	Max. (= MOPD) liquid ²⁾					
		10 W a.c.	12 W a.c.	20 W d.c.			
EVRA 3	0.00	21	25	14	-40 105	42	0.23
EVRA 10	0.05	21	25	18			1.5
EVRAT 10	0.00	14	21	16			1.5
EVRA 15	0.05	21	25	18			2.7
EVRAT 15	0.00	14	21	16			4.5
EVRA 20	0.05	21	25	13			4.5
EVRAT 20	0.00	14	21	13			10.0
EVRA 25	0.20	21	25	14			16.0
EVRA 32	0.20	21	25	14			25.0
EVRA 40	0.20	21	25	14			

¹⁾ The k_v value is the water flow in m³/h at a pressure drop across valve of 1 bar, $\rho = 1000 \text{ kg/m}^3$.

²⁾ MOPD for media in gas form is approx. 1 bar greater.

Code numbers

Complete valves without flanges

	Type	Connection	Code no. ¹⁾	
			10 W coil with 1 m cable	10 W coil with terminal box
Valves with manual operation	EVRA 3	See table "Flange set"	032F3102	032F3103
	EVRA 10		032F6207	032F6208
Valves without manual operation	EVRA 10	See table "Flange set"	032F6212	032F6213
	EVRA 15		032F6217	032F6218
	EVRA 20		032F6222	032F6223

¹⁾ Valve body with gaskets, bolts and 10 W a.c. coil. Please specify code no., voltage and frequency. Voltage and frequency can also be given in the form of an appendix number, see table "Appendix numbers", under EVR.

Separate valve bodies

	Type	Connection	Required coil type	Code no.
Valves with manual operation	EVRA 10	See table Flange set	a.c. / d.c.	032F6210
	EVRAT 10		a.c. / d.c.	032F6214
	EVRA 15		a.c. / d.c.	032F6215
	EVRAT 15		a.c. / d.c.	032F6216
	EVRA 20		a.c.	032F6220
	EVRA 20		d.c.	032F6221
	EVRAT 20		a.c. / d.c.	032F6219
	EVRA 25		a.c. / d.c.	032F6225
Valves without manual operation	EVRA 3	See table Flange set	a.c. / d.c.	032F3050
	EVRA 10		a.c. / d.c.	032F6211
	EVRA 25		a.c. / d.c.	032F6226

Separate valve bodies with butt weld connections

	Type	Size	Butt weld connection	
			DIN	ANSI
			Code no.	Code no.
Valves with manual operation	EVRA 32	1 ¼ in.	042H1126	042H1140
	EVRA 32	1 ½ in.	042H1131	042H1141
	EVRA 40	1 ½ in.	042H1128	042H1142
	EVRA 40	2 in.	042H1132	042H1143

Flange sets

	Connection	Code no.		
			mm	in.
EVRA 3, 10 and 15 EVRAT 10 and 15	Butt welding DIN (2448), Tongue flange sets	10	3/8	027N1112
		15	1/2	027N1115
		20	3/4	027N1120
	Butt welding ANSI B 36.10, Tongue flange sets	10	3/8	027N2020
		15	1/2	027N2021
		20	3/4	027N2022
	Socket welding ANSI (B 16.11), Tongue flange sets	10	3/8	027N2010
		15	1/2	027N2011
	Solder DIN (2856), Tongue flange sets	16		027L1116
		22		027L1122
	Solder ANSI B 16.22, Tongue flange sets		5/8	027L1117
			7/8	027L1123
	FPT internal thread, NPT (ANSI / ASME B 1.20.1), Tongue flange sets	10	3/8	027G1005
		15	1/2	027G1006
EVRA 20 and 25 EVRAT 20	Butt welding DIN (2448), Tongue flange sets	20	3/4	027N1220
		25	1	027N1225
		32	1 ¼	027N1230
	Butt welding ANSI B 36.10, Tongue flange sets	20	3/4	027N3031
		25	1	027N3032
		32	1 ¼	027N3033
	Socket welding ANSI (B 16.11), Tongue flange sets	20	3/4	027N2001
		25	1	027N2002
	Soldering DIN (2856), Tongue flange sets	22		027N1222
		28		027N1228
	Soldering ANSI B 16.22, Tongue flange sets		7/8	027N1223
			1 1/8	027N1229
		20	3/4	027G1001
	FPT internal thread, NPT (ANSI / ASME B 1.20.1), Tongue flange sets	25	1	027G1002



VHV and STF: 4-way reversing valves

Pilot operated 4-way reversing valves allow an inversion of the refrigeration cycle, changing from cooling mode in summer to heating mode in winter. 4 way valves are also used in defrost cycles in order to allow hot gas to be sent into iced up evaporators. The cycle inversion is initiated by a small solenoid pilot valve, which controls the movement of a slider, and in turn governs the refrigerant flow path. The valve is connected to the discharge and suction of the compressor.

Features

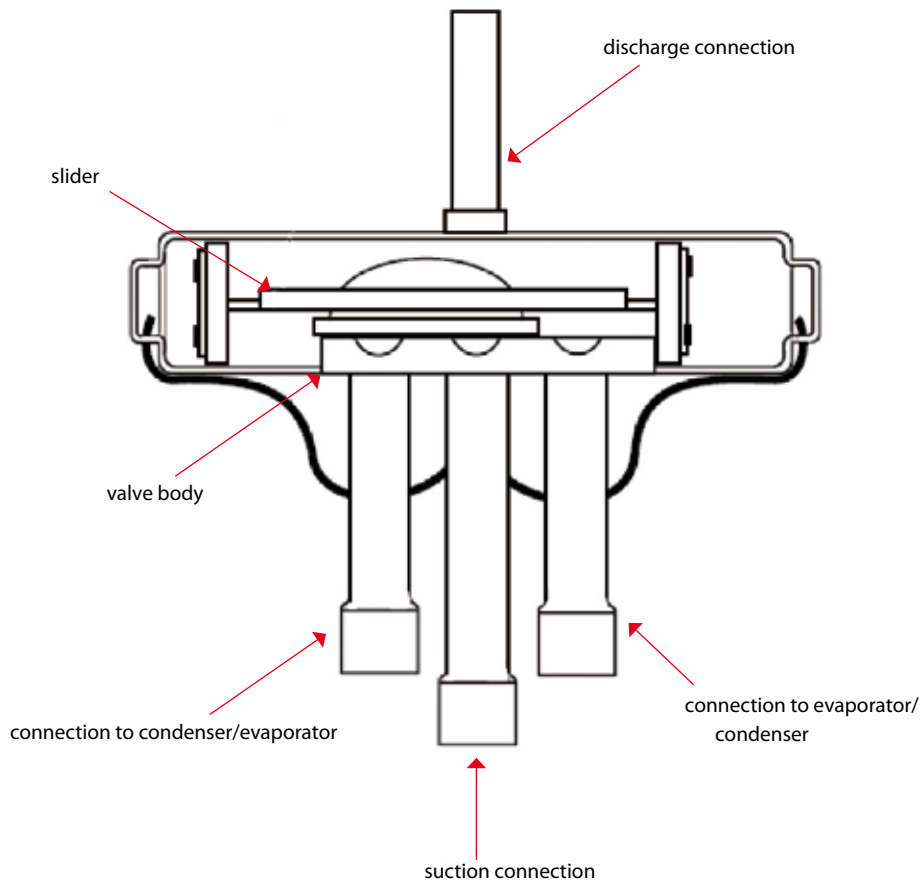

Applications	Advantages	Facts
<ul style="list-style-type: none"> Heat pump applications Reversing chillers Packaged air conditioning systems Room air conditioning systems 	<ul style="list-style-type: none"> Each model can be used with R410A refrigerant as well as R407C, R134a, R404A, R22 Different tube diameters and configurations available Designed for instantaneous changeover with minimum pressure differential Minimized leakage in the valve Reduced pressure drop due to unique design (shape of internal elements) 	<ul style="list-style-type: none"> Wide application range for all commonly used refrigerants: (R134A, R404A, R407C, R22 and R410A) Max. working pressure: 45 bar Ambient temperature: -20 to 55°C Full capacity range up to 400 kW Largest valve available on the market (VHV-6001) 30 years of experience and know-how

Technical data and ordering

Model	Discharge		Suction		Nominal capacity ¹⁾	Style	Code no.	Box qty
	mm	inch	mm	in.				
STF-0101G	8.10	5/16	9.70	3/8	1.6 - 5.1	A	061L1206	4
STF-0101G	8.10	5/16	9.70	3/8	1.6 - 5.1	A	061L1188	45
STF-0104G	8.10	5/16	9.70	3/8	2.4 - 6.4	A	061L1143	45
STF-0201G	9.70	3/8	12.95	1/2	2.8 - 11.4	A	061L1207	3
STF-0201G	9.70	3/8	12.95	1/2	2.8 - 11.4	A	061L1144	32
STF-0202G	9.70	3/8	12.95	1/2	3.8 - 10.3	A	061L1139	32
STF-0204G	9.70	3/8	16.03	5/8	2.8 - 11.4	D	061L1145	32
STF-0205G	8.10	5/16	12.95	1/2	2.8 - 11.4	B	061L1146	32
STF-0208G	9.70	3/8	16.03	5/8	2.8 - 11.4	C	061L1147	32
STF-0209G	9.70	3/8	12.95	1/2	2.8 - 11.4	B	061L1148	32
STF-0214G	12.95	1/2	16.03	5/8	2.8 - 11.4	D	061L1149	32
STF-0301G	12.95	1/2	16.15	5/8	5.3 - 14.6	E	061L1208	4
STF-0301G	12.95	1/2	16.15	5/8	5.3 - 14.6	E	061L1150	32
STF-0306G	12.95	1/2	19.2	3/4	5.3 - 14.6	E	061L1151	32
STF-0401G	12.80	1/2	19.15	3/4	8.3 - 29.2	B	061L1209	2
STF-0401G	12.80	1/2	19.15	3/4	8.3 - 29.2	B	061L1152	24
STF-0404G	12.80	1/2	19.15	3/4	8.4 - 33	B	061L1193	24
STF-0409G	12.80	1/2	22.40	7/8	8.3 - 29.2	B	061L1154	24
STF-0413G	16.00	5/8	22.40	7/8	8.3 - 29.2	B	061L1155	24
STF-0420G	12.80	1/2	22.40	7/8	8.4 - 33	B	061L1156	24
STF-0712G	19.15	3/4	22.30	7/8	21 - 53	B	061L1223	1
STF-0712G	19.15	3/4	22.30	7/8	21 - 53	B	061L1195	6
STF-0715G	22.50	7/8	28.70	1 1/8	21 - 53	B	061L1158	6
STF-0728G	22.50	7/8	22.30	7/8	21 - 53	B	061L1160	6
STF-1511G	22.50	7/8	28.90	1 1/8	41 - 61	F	061L1224	1
STF-1513G	22.50	7/8	35.22	1 3/8	41 - 61	F	061L1217	1
STF-1514G	28.90	1 1/8	35.22	1 3/8	41 - 61	F	061L1218	1
STF-2011G	22.50	7/8	28.90	1 1/8	41 - 77	B	061L1219	1
STF-2017G	28.70	1 1/8	45.15	1 3/8	41 - 77	B	061L1225	1
VHV-2501 ²⁾	25.70	1	32.05	1 1/4	55 - 98	G	061L1175	1
VHV-2505	28.70	1 1/8	45.15	1 3/8	55 - 98	G	061L1191	1
VHV-2506	28.70	1 1/8	41.70	1 5/8	55 - 98	G	061L1192	1
VHV-3001	32.05	1 1/4	38.40	1 1/2	68 - 129	G	061L1176	1
VHV-3003	28.50 ³⁾	1 1/8	41.70	1 5/8	68 - 129	G	061L1183	1
VHV-4001	38.35	1 1/2	45.15	1 3/4	122 - 195	G	061L1179	1
VHV-4002	41.20 ³⁾	1 5/8	41.70	1 5/8	122 - 195	G	061L1184	1
VHV-5001	38.35	1 1/2	54.40	2 1/8	183 - 256	G	061L1180	1
VHV-5002	41.20 ³⁾	1 5/8	54.40	2 1/8	183 - 256	G	061L1185	1
VHV-6001	41.20 ³⁾	1 5/8	67.00	2 5/8	267 - 374	G	061L1186	1

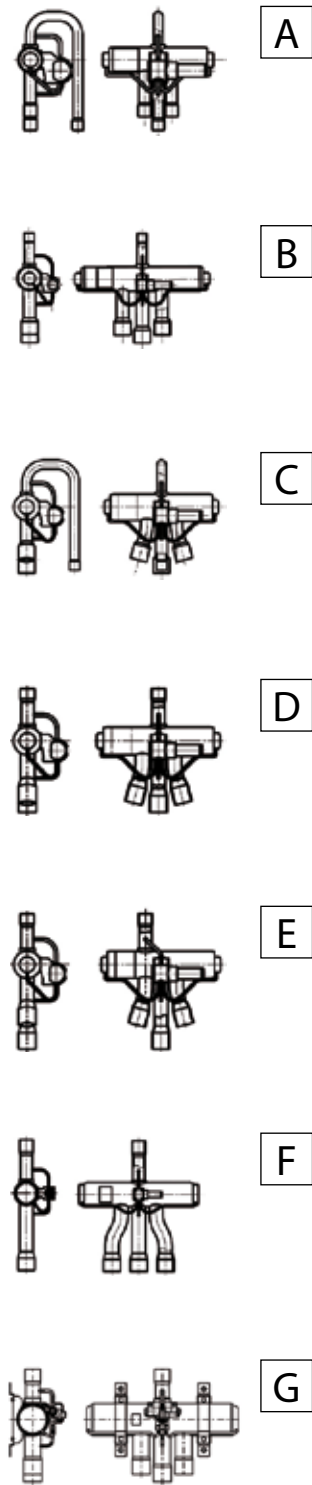

Model ⁴⁾	Cable length mm	Rated voltage	Code no.	Box qty
STF-01AB500A1	600	24 V AC	061F2092	10
STF-01AB503B1	1200	24 V AC	061L2038	100
STF-01AJ506B1	600	220-240 V AC	061L2093	10
STF-01AJ504F1	1200	208-240 V AC	061L2016	100
STF-01AJ504F1	1200	208-240 V AC	061L2094	10
STF-01AJ512D1	2000	220-240 V AC	061L2095	10
STF-01AJ512D1	2000	220-240 V AC	061L2074	60

1) The nominal capacities for R407C

2) VHV-2501 does not have a bracket

3) Refers to O.D.

4) STF coils can be used with all STF and VHV valves





KP: excellent operation and easy installation

KP pressure controls are designed to protect refrigeration systems from excessively high discharge pressures, excessively low suction pressures, to start/stop compressors or to operate fans of aircooled condensers. KP thermostats with adsorption charge are the optimum choice for frost protection of chillers. The enhanced contact system for 16 Amp makes it possible to operate electrical motors up to 2 kW directly, without the use of contactors.

Features

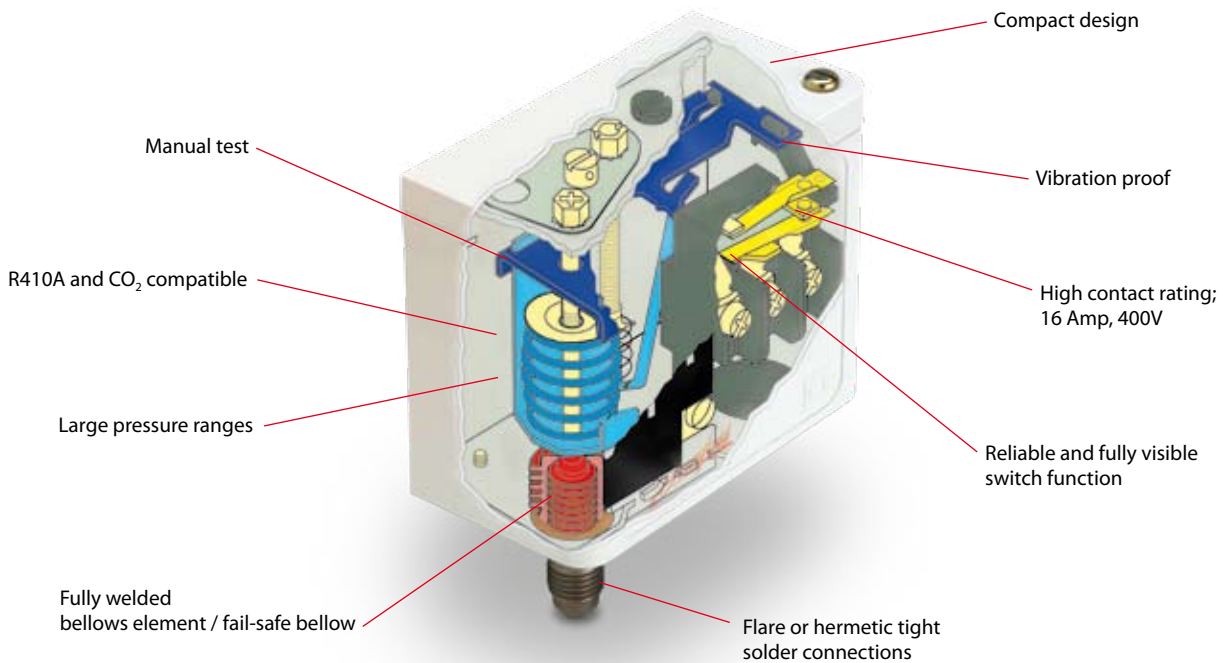

Applications	Advantages	Facts
<ul style="list-style-type: none"> · Traditional refrigeration · Heat pump systems · Air conditioning units · Liquid coolers · Transport refrigeration 	<ul style="list-style-type: none"> · Easy to handle compact design with large and visible scale plates. · Particularly vibration and shock resistant. · Accurate and reliable compressor operation due to excellent electro-mechanical function. · Easy functional check with manual test function of contact system (no tools). · Easy to install electrical connection which also facilitates rack mounting. 	<ul style="list-style-type: none"> · Can be used for all fluorinated refrigerants. · Approval: CE and UL. · Pressure controls available with flare, solder or capillary tube connections. · Thermostats available with capillary sensor, air sensor or cylindrical pocket sensor. · IP30 and IP44 enclosures available. · KP 6, 7 and 17 with fail-safe bellows element.

Technical data and ordering

Pressure controls for fluorinated refrigerants

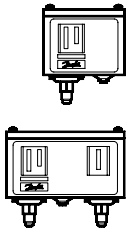

Type	Pressure	Low pressure (LP)		High pressure (HP)		Reset		Contact system	Code no. ¹⁾		
		Regulating range bar	Differential Δp bar	Regulating range bar	Differential Δp bar	LP	HP		¼ in. 6 mm flare	¼ in. ODF solder	6 mm ODF solder
KP 5	High			8 32	1.8 6.0		Aut.	SPDT	060-117166	060-117966	060-117766
					Fixed 3				Man.	060-117366	060-118066
KP 15	Dual	-0.2 7.5	0.7 4.0	8 32	Fixed 4	Aut.	Aut.	SPDT + LP signal	060-124166	060-125466	
							Man.		060-124366		
							Aut.	SPDT + LP/HP signal	060-126566	060-129966	
							Man.		060-126466	060-128466	
Conv.	Conv.	060-115466	060-001066								

Pressure controls with DIN 32733 approval, for fluorinated refrigerants

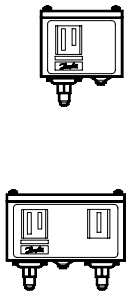

Type ²⁾	Pressure	Low pressure (LP)		High pressure (HP)		Reset		Contact system	Code no. ¹⁾		
		Regulating range bar	Differential Δp bar	Regulating range bar	Differential Δp bar	LP	HP		¼ in. 6 mm flare	¼ in. ODF solder	6 mm ODF solder
KP 1	Low	-0.2 7.5	0.7 4.0			Aut.		SPDT	060-110166	060-111266	060-111066
		-0.9 7.0	Fixed 0.7						Man.	060-110366	060-111166
KP 2	Low	-0.2 5.0	0.4 1.5			Aut.		SPDT	060-112066		060-112366
KP 6W	High			8 42	4 10		Aut.	SPDT	060-519066		
KP 6B	High			8 42	Fixed 4		Man.	SPDT	060-519166		
KP 7W	High			8 32	4 10		Aut.	SPDT	060-119066		060-120366
KP 7B	High			8 32	Fixed 4		Man.	SPDT	060-119166		
KP 7BS	Dual			8 32	Fixed 4		Man./Man.	SPST	060-120066		
KP 17W	Dual	-0.2 7.5	0.7 4	8 32	Fixed 4	Aut.	Aut.	SPDT + LP/HP signal	060-127566		060-127666
KP 17B	Dual	-0.2 7.5	0.7 4	8 32	Fixed 4	Aut.	Man.	SPDT	060-126866		060-127466
KP17WB	Dual	-0.2 7.5	Fixed 1	8 32	Fixed 4	Conv.	Conv.	SPDT + LP/HP signal	060-539766		

Thermostats

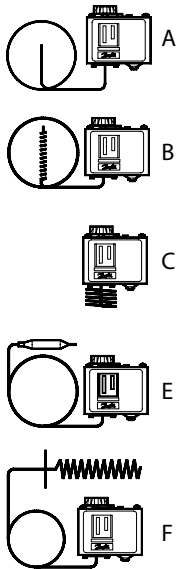

Type	Setting range °C	Differential Δt		Charge	Bulb type	Reset	Max. bulb temp. °C	Capillary-tube in m	Code no. ¹⁾
		Lowest temperature °C	Highest temperature °C						
KP 61	-30 15	5.5 23	1.5 7	Vapour	A	aut.	120	2	060L110066
	-30 13	4.5 23	1.2 7	Vapour	B	aut.	120	2	060L110166
	-30 15	5.5 23	1.5 7	Vapour	B	aut.	120	2	060L110366 060L112866
KP 62	-30 15	6.0 23	1.5 7	Vapour	C	aut.	120		060L110666
KP 63	-50 -10	10.0 70	2.7 8	Vapour	B	aut.	120	2	060L110866
KP 68	-5 35	4.5 25	1.8 7	Vapour	C	aut.	120		060L111166
KP 69	-5 35	4.5 25	1.8 7	Vapour	B	aut.	120	2	060L111266
KP 62	-30 15	5.0 20	2.0 8	Adsorbition	C	aut.	80		060L111066
KP 71	-5 20	3.0 10	2.2 9	Adsorbition	E	aut.	80	2	060L111366
	-25 15	12.0 70	8.0 25	Adsorbition	E	aut.	80	2	060L111766
	-20 15	4.0 15	2.0 13				55	3	060L114066
-25 15	3.5 20	3.25 18	80				2	060L114366	
KP 75	0 35	3.5 16	2.5 12	Adsorbition	F	aut.	110	2	060L112066
					E				060L113766
KP 77	20 60	3.5 10	3.5 10	Adsorbition	E	aut.	130	2	060L112166
KP 98	OIL: 60 120	OIL: Fixed 14	OIL: Fixed 14	Adsorbition	E	max.	150	1	060L113166
	HT: 100 180	HT: Fixed 25	HT: Fixed 25				250	2	

Mounting brackets

Type	Code no. ¹⁾
Wall bracket	060-105666
Angle bracket	060-105666

¹⁾ Code numbers in bold are normally on stock and a shorter delivery time can therefore be expected.

²⁾ KP 6, 7 and 17 with fail-safe bellows element.



ACB: Cartridge Pressure Controls

The ACB series cartridge switches, are small disc type pressure controls manufactured by Danfoss Saginomiya in Poland. The core steps of the manufacturing process of these controls are carried out using precision manufacturing techniques, and within a clean-room environment. This ensures that product specifications can be guaranteed over a longer period, providing reliable performance during the whole product lifetime.

Features

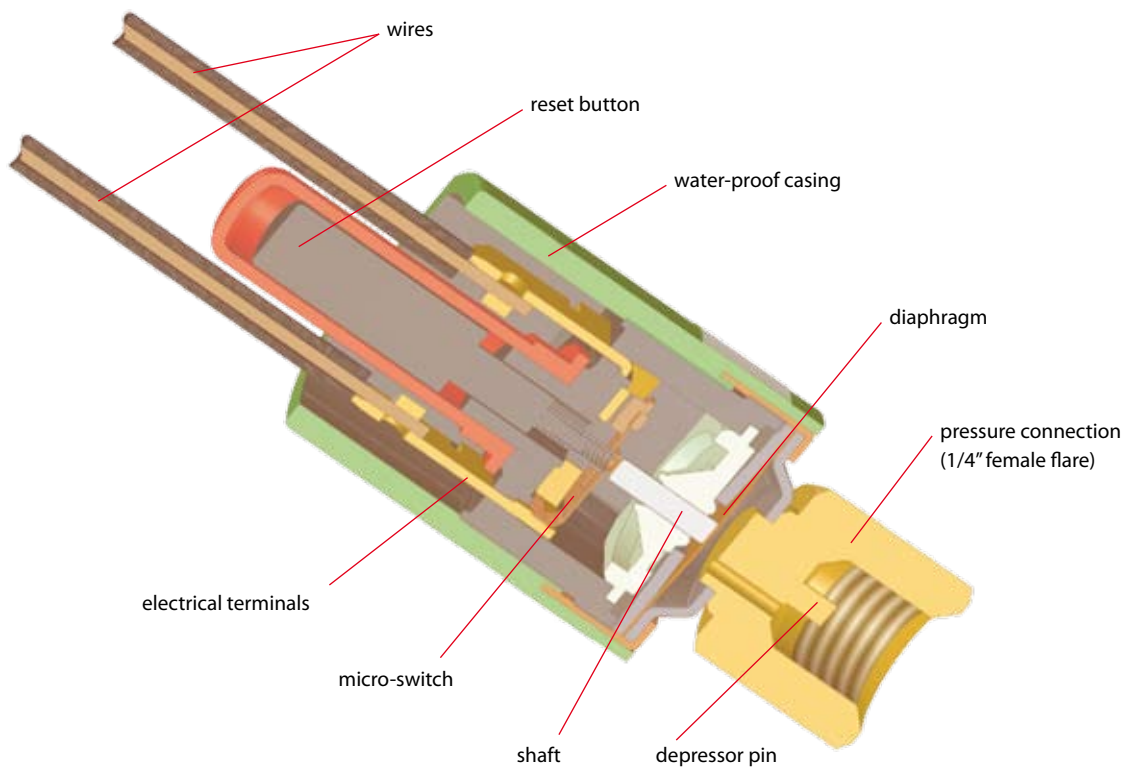

Fig.: type SPST manual reset

Applications	Advantages	Facts
<ul style="list-style-type: none"> Traditional refrigeration Heat pump systems Air conditioning units Liquid coolers Transport refrigeration 	<ul style="list-style-type: none"> Compact and easy to install Excellent reliability and repeatability Wide choice of specifications: set-point, pressure connection, electrical connection Flexible order quantity due to European production with short lead times Global coverage and widespread use at all major OEMs Over 100million pcs installed in the field 	<ul style="list-style-type: none"> CE, TÜV, VDE, UL and C-UL approvals (SPDT man. only CE approvals) Contact load up to 6 A (250 V AC) Normally Closed (NC), Normally Open (NO) or SPDT contact system Spades or cables (1,5 m cable for standard program) Pressure range from - 0,50 bar to 45 bar Automatic or manual reset IP 65 (water proof version with cables) and IP40 (version with spade connectors) available

Technical data and ordering

Application	Reset	Cut out	Cut in	Contact system/ enclosure type: W-water-proof 1) S-with spades 2)	Connection		
		bar	bar		Solder		1/4" female flare
					6mm	1/4"	
High pressure cut out	automatic	18 ± 0,7	13 ± 1,2	SPST-NC / W	061F7504	061F7505	061F7506
				SPST-NC / S	-	061F8711	061F8709
				SPDT / W	-	-	061F9057
	automatic	20 ± 1,0	16 ± 1,5	SPST-NC / S	-	061F8710	061F8708
	automatic	23 ± 1,0	19 ± 1,5	SPST-NC / S	-	061F8707	061F8703
	automatic	23 ± 0,7	19 ± 1,2	SPST-NC / W	-	-	061F8494
				SPDT / W	-	-	061F9056
	manual				-	-	061F9243
	automatic	26 ± 1,0	20 ± 1,5	SPST-NC / W	061F7507	061F7508	061F7509
				SPST-NC / S	-	061F8705	061F8701
				SPDT / S	-	061F9104	061F9100
	automatic			SPDT / W	-	-	061F9055
	manual	26 ± 1,0	20 ± 2,0	SPST-NC / W	061F9703	061F9714	061F9713
	automatic	28 ± 1,0	21 ± 1,5	SPST-NC / W	061F7510	061F7513	061F7514
	automatic			SPST-NC / S	-	061F8704	061F8700
	automatic			SPDT / W	-	-	061F9054
				SPDT / S	-	061F9107	061F9103
	manual			SPDT / W	-	-	061F9242
	manual	28 ± 1,0	21 ± 2,0	SPST-NC / W	-	-	061F9522
	automatic	31 ± 1,0	24 ± 1,5	SPST-NC / W	061F8493	-	061F8492
				SPST-NC / S	-	061F8706	061F8702
				SPDT / W	-	-	061F9053
	automatic	42 ± 1,2	33 ± 2,0	SPST-NC / W	061F7515	061F7516	061F7517
					-	-	061F9575
SPDT / W				-	-	061F9052	
Low pressure cut-out	automatic	0,5 ± 0,4	1,5 ± 0,3	SPST-NO / W	061F7518	061F7519	061F7520
		0,5 ± 0,5	1,5 ± 0,5	SPST-NO / S	-	061F7402	061F7400
				SPDT / S	-	061F9106	061F9102
	automatic	0,7 ± 0,5	1,7 ± 0,4	SPST-NO / W	061F7521	061F7522	061F7523
				SPDT / W	-	-	061F9058
		0,7 ± 0,5	1,7 ± 0,5	SPST-NO / S	-	061F7403	061F7401
				SPDT / S	-	061F9105	061F9101
	automatic	1,7 ± 0,5	2,7 ± 0,4	SPST-NO / W	061F7524	061F7525	061F7526
Fan Control	automatic	8,5 ± 1,2	11 ± 0,8	SPST-NO / W	061F8491	-	061F8490
		13 ± 1,5	16 ± 1,0		061F8334	-	061F8333

¹⁾ Waterproof models (IP 65) with 1,5 m wires AWG18, packed per 20 pcs

²⁾ Models with spade connectors (IP 40), packed per 50 pcs

UT: Simple and easy temperature control

The UT thermostat is a temperature-controlled thermostat with stainless steel (18/8) or copper capillary and sensor. The temperature must be set to correspond to the required mean temperature. The thermostat has a fixed differential.

Features

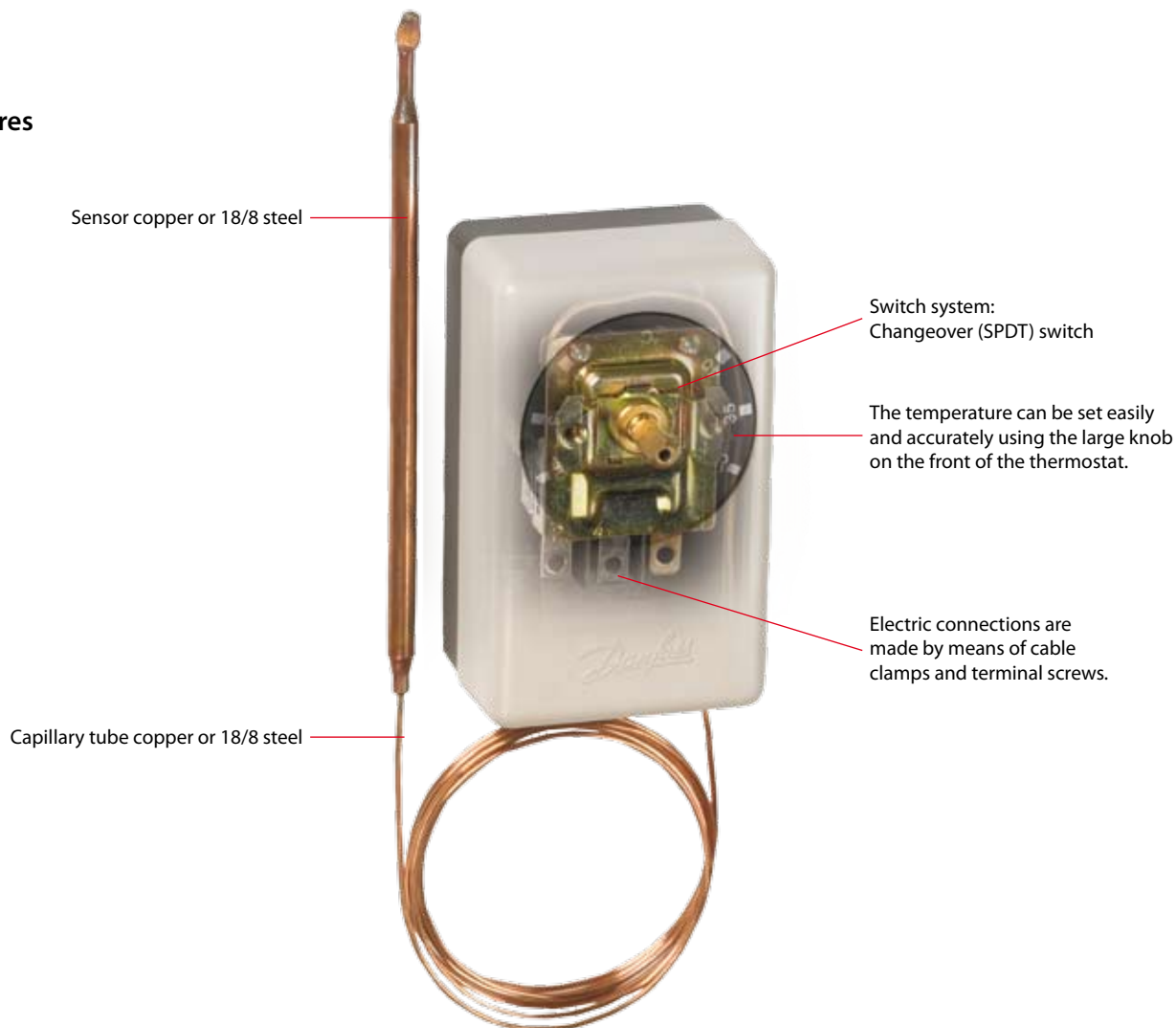

Applications	Advantages	Facts
<ul style="list-style-type: none"> · Cold rooms · Beverage coolers · Ice cream makers · Milk coolers · Refrigerated counters · Air-conditioning plant · Heat recovery systems 	<ul style="list-style-type: none"> · UT is available for wall or panel mounting · UT for wall mounting: IP 20 to EN 60529/IEC 52 · UT for panel mounting: IP 00 to EN 60529/IEC 529 	<ul style="list-style-type: none"> · UT 72 for universal use -30 to 30°C · UT 73 for frost protection 0 to 40°C · Differential is fixed 2.3°K · Automatic reset · Contact load: <ul style="list-style-type: none"> - AC 1: 10 A, 250/380 V (ohmic) - AC 11: 2.5 A, 250/380 V (induct.)

Technical data and ordering

Version	Type	Range °C	Differential K	Reset	Max. sensor temperature °C	Capillary tube length m	Qty.	Code no.	
								Copper	18/8
Wall mounting	UT 72	-30 30	2.3	aut.	60	1.5	1	060H1101	060H1106
	UT 72	-30 30	2.3	aut.	60	1.5	1	060H1103 ¹⁾	
	UT 72	-30 30	2.3	aut.	60	1.5	20	060H1104	
	UT 72	-30 30	2.3	aut.	60	3.0	1	060H1105	
	UT 73	0 40	2.3	aut.	90	1.5	1	060H1102	
Panel mounting	UT 72	-30 30	2.3	aut.	60	1.5	48	060H1201	
	UT 72	-30 30	2.3	aut.	60	3.0	48	060H1205	
	UT 73	0 40	2.3	aut.	90	1.5	48	060H1202	

¹⁾ Incl. bulb clamps

Accessories

	Qty.	UT 72	UT 73
Setting knobs	48	060-1067	060-1096
Bulb clamp	36	060-1090	060-1090



RT: pressure and temperature controls

The RT series includes thermostats and pressure controls for general applications within industrial and marine refrigeration. An RT thermostat is fitted with a single-pole changeover switch. The position of the contacts depends on the bulb temperature and the set scale value. An RT pressure control contains a pressure operated single-pole changeover contact, the position of which depends on the pressure in the in let connection and the set scale value.

Features

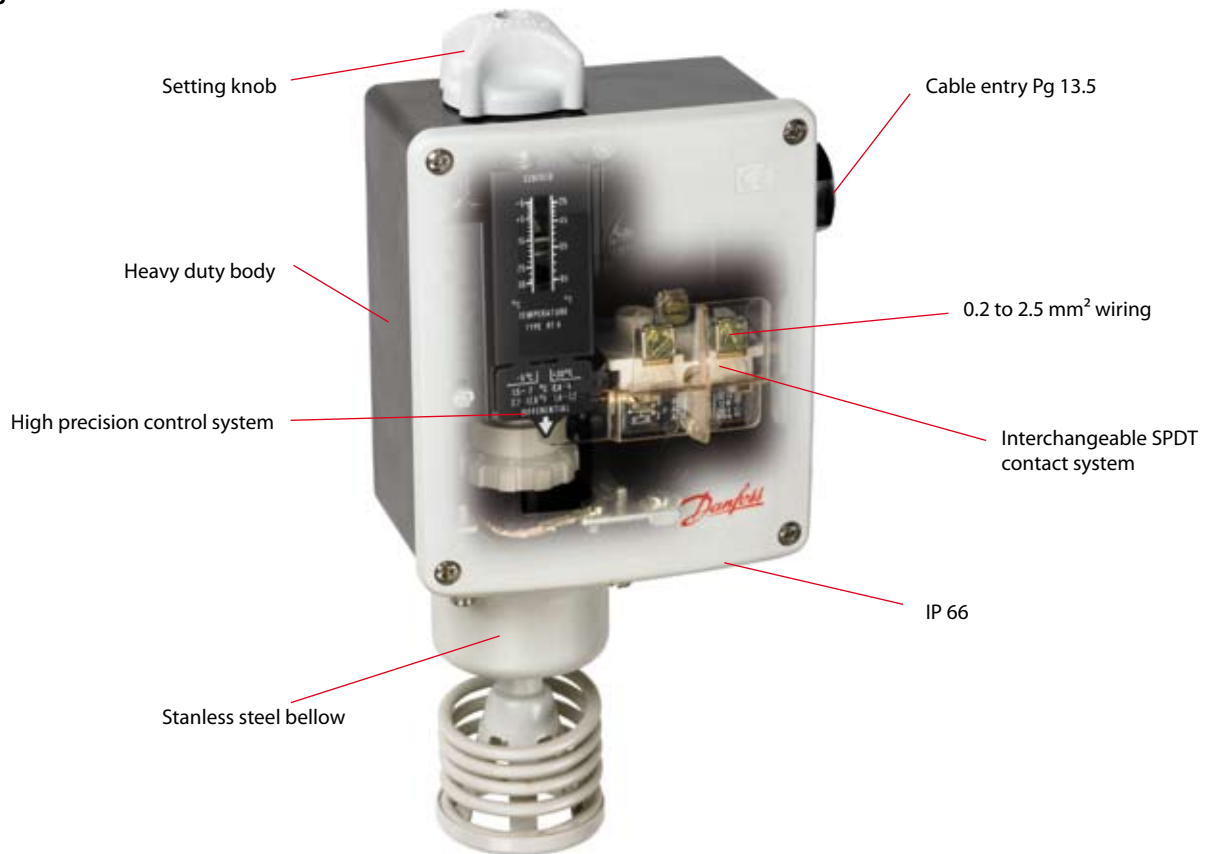



Applications	Advantages	Facts
<ul style="list-style-type: none"> General applications within industrial and marine refrigeration 	<ul style="list-style-type: none"> Wide regulating range Suitable for alternating and direct current Interchangeable contact system Special versions with gold plated contact surfaces for PLC applications Versions for neutral zone regulation Waterproof versions, enclosure IP 66 High stability and accuracy Long operating life time 	<ul style="list-style-type: none"> Enclosure: IP 66 to EN 60529 / IEC 60529, except for versions with ext. reset which are to IP 54 Short circuit protection, fuse 10 Amp Insulation 400 V Ambient temperature: -50 to +70°C for housing Cable connection: Pg 13.5. Cable diameter: 6 14 mm. Pressure controls for fluorinated refrigerants and R717 (NH₃)

Technical data and ordering: RT temperature controls

Charge	Type	Bulb type	Regulation range °C	Differential Δt		Reset	Max. bulb temp. °C	Capillary tube length m	Code no.
				Lowest temp. setting K	Highest temp. setting K				
Vapour ¹⁾	RT 10	A	-60 -25	1.7 7.0	1.0 3.0	aut.	150	2	017-507766
	RT 9	A	-45 -15	2.2 10.0	1.0 4.5	aut.	150	2	017-506666
	RT 3	A	-25 +15	2.8 10.0	1.0 4.0	aut.	150	2	017-501466
	RT 17	B	-50 -15	2.2 7.0	1.5 5.0	aut.	100		017-511766
	RT 11	B	-30 0	1.5 6.0	1.0 3.0	aut.	66		017-508366
	RT 4	B	-5 +30	1.5 7.0	1.2 4.0	aut.	75		017-503666 017-503766 ⁴⁾
Adsorption ²⁾	RT 13	A	-30 0	1.5 6.0	1.0 3.0	aut.	150	2	017-509766
	RT 2	A	-25 +15	5.0 18.0	6.0 20.0	aut.	150	2	017-500866
	RT 8	A	-20 +12	1.5 7.0	1.5 7.0	aut.	145	2	017-506366
	RT 12	A	-5 +10	1.0 3.5	1.0 3.0	aut.	65	2	017-508966
	RT 23	A	+5 +22	1.1 3.5	1.0 3.0	aut.	85	2	017-527866
	RT 15	A	+8 +32	1.6 8.0	1.6 8.0	aut.	150	2	017-511566
	RT 24	A	+15 +34	1.4 4.0	1.4 3.5	aut.	105	2	017-528566
	RT 140	C	+15 +45	1.8 8.0	2.5 11.0	aut.	240	2	017-523666
	RT 102	D	+25 +90	2.4 10.0	3.5 20.0	aut.	300	2	017-514766
	RT 34	B	-25 +15	2.0 10.0	2.0 12.0	aut.	100		017-511866
	RT 7	A	-25 +15	2.0 10.0	2.5 14.0	aut.	150	2	017-505366
	RT 14	A	-5 +30	2.0 8.0	2.0 10.0	aut.	150	2	017-509966
Partial ³⁾	RT 101	A	+25 +90	2.4 10.0	3.5 20.0	aut.	300	2	017-500366
Partial ³⁾	RT 107	A	+70 +150	6.0 25.0	1.8 8.0	aut.	215	2	017-513566

¹⁾ The sensor must be located colder than thermostat housing and capillary tube. ²⁾ The sensor can be located warmer or colder than thermostat housing. ³⁾ The sensor must be located warmer than thermostat housing and capillary tube. ⁴⁾ With built-in heating coil - reduces the thermal differential.

Type of bulb / sensor

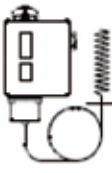
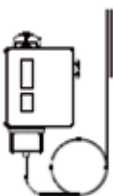
A	B	C	D
			
Cylindrical remote sensor	Room sensor	Duct sensor	Capillary tube sensor

Technical data and ordering: RT pressure controls

Safety pressure controls w EN 12263 / DIN 32733 appr. and CE marked acc. PED, Pressure Equipment Directive

Pressure	Type	Regulation range bar	Differential (fixed) Δp bar	Reset	Max. working pressure PB bar	Max. test pressure p' bar	Code no.			
							Connection			
							1/4 in./ 6mm flare	cutting ring 6 mm	G 3/8 A ¹⁾ + weld nipple 6.5/10 mm	G1/2 A ¹⁾
High	RT 36B ²⁾	0 2.5	max. 0.2	man.	22	25	017-525866			
	RT 36S ²⁾	0 2.5	max. 0.2	man.	22	25	017-525966			
High	RT 6W ²⁾	5 25	2.0 - 3.0	aut.	34	38	017-503166			
	RT 6B ²⁾	10 28	max. 1.0	man.	34	38	017-503466			
	RT 6S ²⁾	10 28	max. 1.0	man.	34	38	017-507566			
High	RT30AW ³⁾	1 10	0.2 - 0.8	aut.	22	25				017-518766
	RT30AB ³⁾	1 10	max. 0.4	man.	22	25				017-518866
	RT30AS ³⁾	1 10	max. 0.4	man.	22	25				017-519966
High	RT6AW ³⁾	5 25	2.0 - 3.0	aut.	34	38		017-513166	017-503266	
	RT6AB ³⁾	10 28	max. 1.5	man.	34	38		017-513366	017-503566	
	RT6AS ³⁾	10 28	max. 1.5	man.	34	38		017-514666	017-507666	

¹⁾ BSP ext. thread, ISO 228/1.

²⁾ Pressure controls for fluorinated refrigerants.

³⁾ Pressure controls for R 717 (NH₃) and fluorinated refrigerants.

Pressure controls with adjustable dead zone for R717 (NH₃) and fluorinated refrigerants

Pressure	Type	Regulation range bar	Differential Δp bar	Dead zone NZ Δp bar	Max. working pressure PB bar	Max. test pressure p' bar	Code no.	
							Connection	
							cutting ring 6 mm	G 3/8 A ¹⁾ + weld nipple 6.5/10 mm
Low	RT 1AL ²⁾	-0.8 5	fixed 0.2	0.2 0.9	22	25	017L001666	017L003366
	RT 200L ³⁾	0.2 6	fixed 0.25	0.25 0.7	22	25		017L003266
High	RT 5AL ²⁾	4 17	fixed 0.35	0.35 1.4	22	25	017L001766 ⁴⁾	017L004066 ⁴⁾
	RT 117L ³⁾	10 30	fixed 1.0	1 3.0	42	47		017L004266 ⁴⁾

¹⁾ BSP ext. thread, ISO 228/1.

²⁾ Pressure controls for R 717 (NH₃) and fluorinated refrigerants.

³⁾ Pressure controls for fluorinated refrigerants.

⁴⁾ Without nipple.

Differential pressure controls for R 717(NH₃) and fluorinated refrigerants

Type	Regulation range bar	Differential Δp bar	Operating range for LP bellows bar	Max. working pressure PB bar	Max. test pressure p' bar	Code no.	
						Connection	
						cutting ring 6 mm	G 3/8 A ¹⁾ + weld nipple 6.5/10 mm
RT 260A	0.5 4	fixed 0.3	-1 18	22	25	017D001466	017D002166
	0.5 4	fixed 0.3	-1 18	22	25		017D002266 ²⁾
	0.5 6	fixed 0.5	-1 36	42	47	017D001566	017D002366
	1.5 11	fixed 0.5	-1 31	42	47	017D001666	017D002466
RT 252A	0.1 1.5	fixed 0.1	-1 9	22	13	017D001366	017D002566
RT 265 ³⁾	1 6	fixed 0.5	-1 36	42	47		017D007266

¹⁾ BSP ext. thread, ISO 228/1.

²⁾ Man. reset.

³⁾ Filter monitor: Alarm $\Delta p = 0.8$ bar, cut-out $\Delta p = 1$ bar (factory setting).

Differential pressure controls with adjustable dead zone for R 717(NH₃) and fluorinated refrigerants

Type	Regulation range bar	Differential Δp bar	Dead zone NZ bar	Operating range for LP bellows bar	Max. working pressure PB bar	Max. test pressure p' bar	Code no.
							Connection
							G 1/2 A ¹⁾ + weld nipple 6.5/10 mm
RT 262 AL	0.1 1.5	fixed 0.1	-1 0.33	-1 9	11	13	017D004366 ²⁾

¹⁾ BSP ext. thread, ISO 228/1.

²⁾ Differential pressure control for R 717 (NH₃) and fluorinated refrigerants.

Overview RT thermostats

-50 0 +50 +100 +150 +200 +250 +300°C								Range °C	Type
Vapour-charged with remote bulb (bulb coldest)								-60 -25	RT 10
								-45 -15	RT 9
								-30 0	RT 13
Adsorption-charged with remote bulb (bulb warmest or coldest)								-25 +15	RT 3
								-25 +15	RT 2,7
								-20 +12	RT 8
Partial charge with remote bulb (bulb warmest)								-5 +10	RT 12
								-5 +30	RT 14
								+5 +22	RT 23
Vapour-charged with coiled capillary tube sensor (room thermostats)								+8 +32	RT 15
								+15 +34	RT 24
								+15 +45	RT 140
Adsorption-charged with coiled capillary tube sensor (room thermostats)								+25 +90	RT 101, 102
								+70 +150	RT 107
								-50 -15	RT 17
Adsorption-charged dead zone thermostats with remote bulb (bulb warmest or coldest)								-30 0	RT 11
								-5 +30	RT 4
								-25 +15	RT 34
Vapour-charged differential thermostats with remote bulb (bulb warmest or coldest)								-20 +12	RT 8L
								-5 +30	RT 14L
								+15 +45	RT 140L
Vapour-charged dead zone thermostat (room thermostat)								0 +38	RT 16L
								-30 +40	RT 270



KVP Evaporator pressure regulator

The KVP is mounted in the suction line after the evaporator and is maintaining a constant evaporating pressure and thereby a constant surface temperature on the evaporator. The regulation is modulating. By throttling in the suction line, the amount of refrigerant gas is matched to the evaporator load.

Features

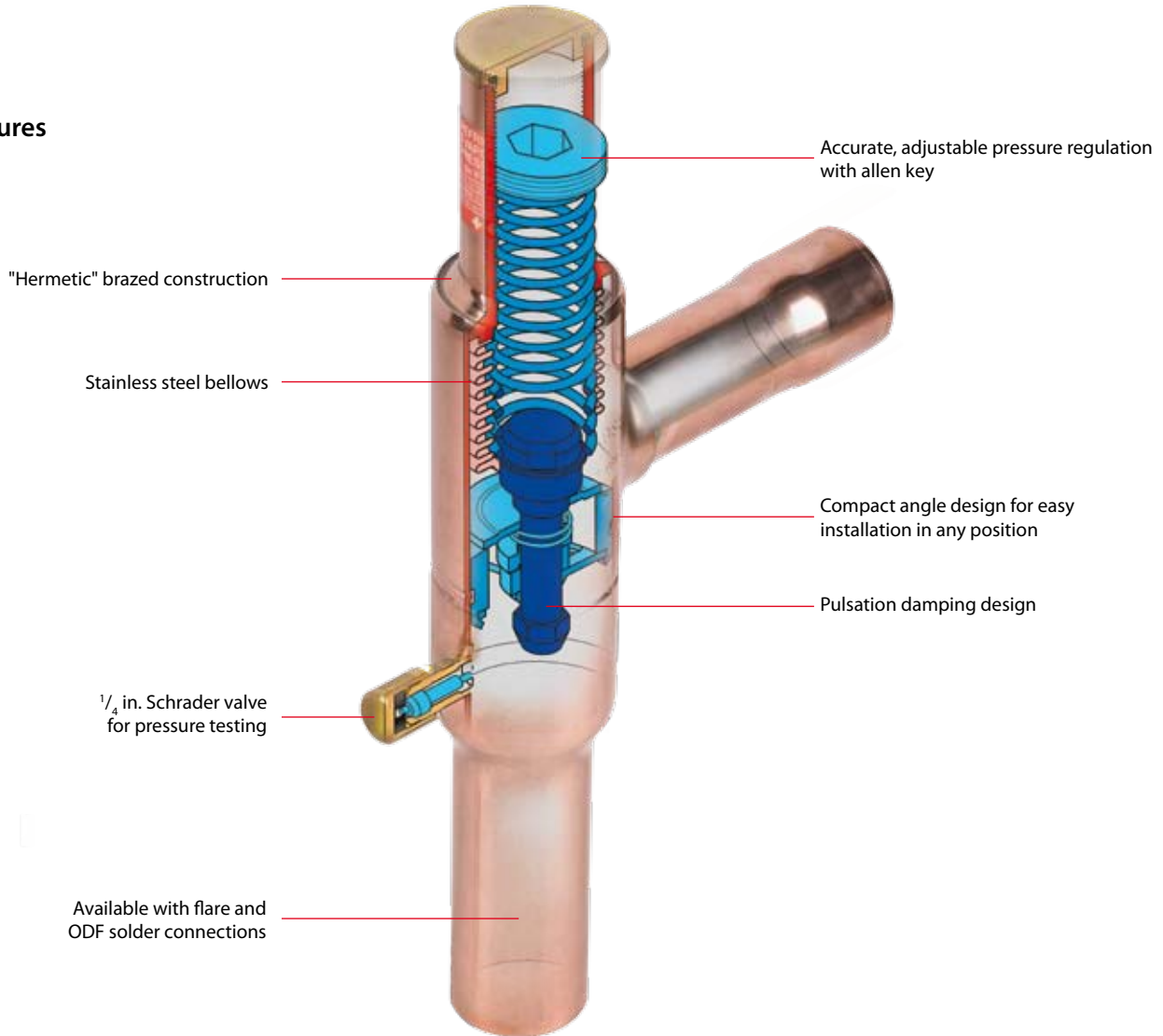

Applications	Advantages	Facts
<ul style="list-style-type: none"> · Traditional refrigeration · Air conditioning units · Transport refrigeration 	<ul style="list-style-type: none"> · The KVP can also be used to differentiate the evaporating pressures in two or more evaporators in systems with one compressor. · Protection against too low an evaporating pressure (e.g. as protection against freezing in a water chiller). The regulator closes when the pressure in the evaporator falls below the set value. 	<ul style="list-style-type: none"> · Wide capacity and operating range · Regulation range: 0 to 5.5 bar · For use with CFC, HCFC and HFC refrigerants

Technical data and ordering

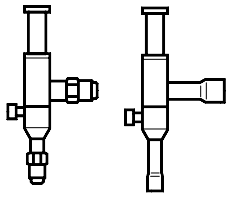

Evaporating pressure regulator

Type	Rated capacity in kW ¹⁾				Flare connection ²⁾³⁾		Code no. ⁴⁾	Solder connection ³⁾		Code no. ⁴⁾
	R22	R134a	R404A/R507	R407C	in.	mm		in.	mm	
KVP 12	4.0	2.8	3.6	3.7	1/2	12	034L0021	1/2		034L0023
									12	
KVP 15	4.0	2.8	3.6	3.7	5/8	16	034L0022	5/8	16	034L0029
KVP 22	4.0	2.8	3.6	3.7				7/8	22	034L0025
KVP 28	8.6	6.1	7.7	7.9				1 1/8		034L0026
									28	
KVP 35	8.6	6.1	7.7	7.9				1 3/8	35	034L0032

¹⁾ Rated capacity is the capacity of the regulator at

- Evaporating temperature $t_e = -10^\circ\text{C}$,
- Condensing temperature $t_c = +25^\circ\text{C}$,
- Pressure drop in regulator $\Delta p = 0.2$ bar, offset = 0.6 bar

²⁾ Supplied without flare nuts. Separate flare nuts can be supplied:
 1/2 in./12 mm, code no. **011L1103**, 5/8 in./16 mm, code no. **011L1167**.

³⁾ The connection dimensions chosen must not be too small, since gas velocities in excess of 40 m/s at the inlet of the regulator can give flow noise.

⁴⁾ Code numbers in bold are normally on stock and a shorter delivery time can therefore be expected.

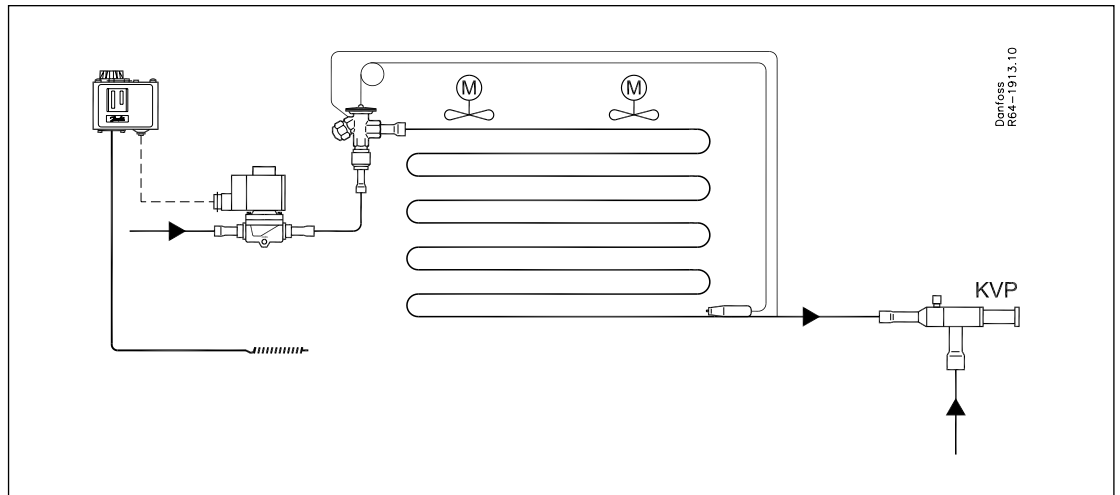



KVR and NRD condensing pressure regulators

Regulator system KVR and NRD is used to maintain a constant and sufficiently high condenser and receiver pressure in refrigeration and air conditioning plant with air-cooled condensers. KVR can also be used together with receiver pressure regulator type KVD.

Features

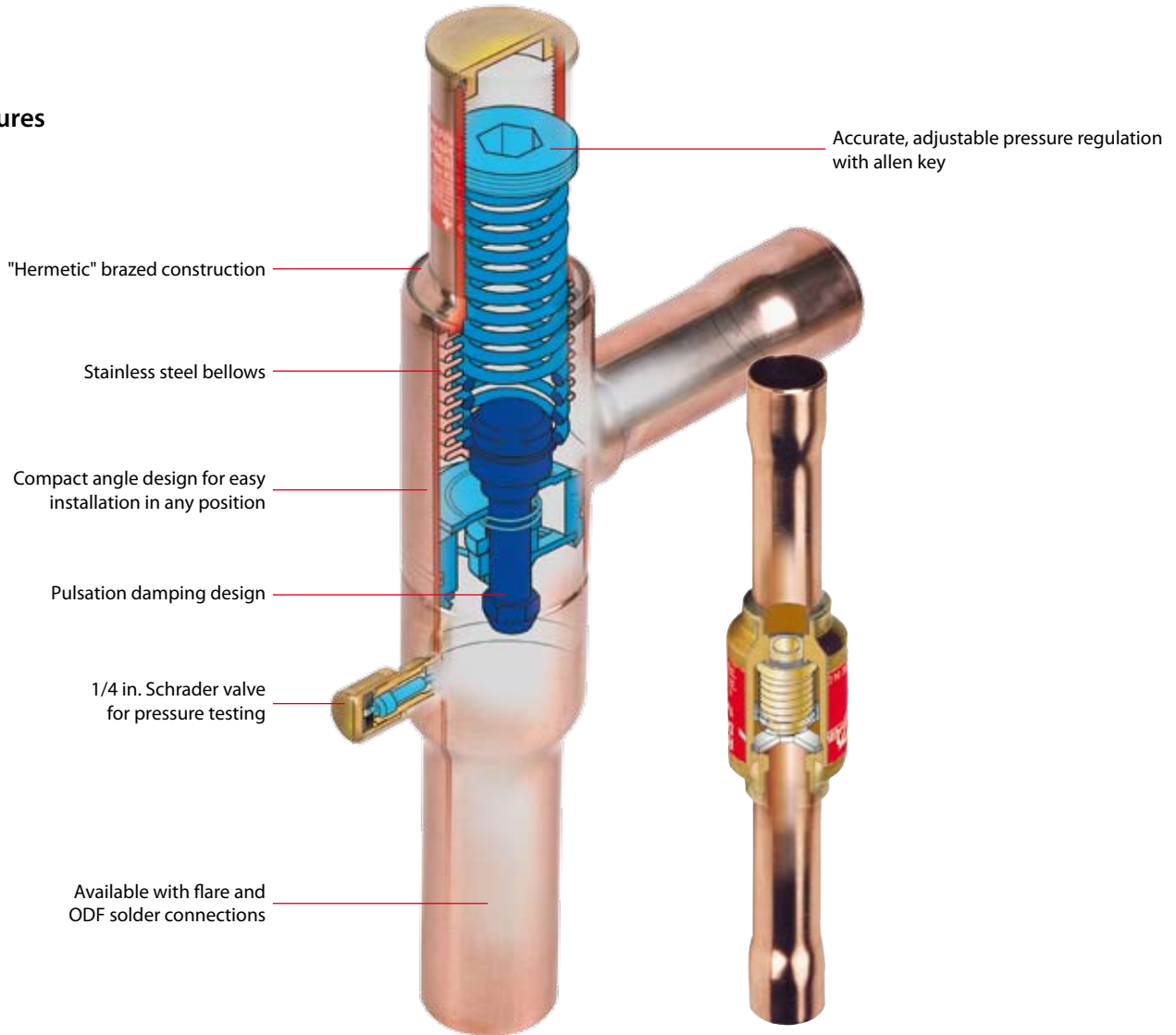

Applications	Advantages	Facts
<ul style="list-style-type: none"> Traditional refrigeration Air conditioning units Transport refrigeration 	<ul style="list-style-type: none"> The KVP can also be used to differentiate the evaporating pressures in two or more evaporators in systems with one compressor. Protection against too low an evaporating pressure (e.g. as protection against freezing in a water chiller). The regulator closes when the pressure in the evaporator falls below the set value. 	<ul style="list-style-type: none"> Wide capacity and operating range Regulation range: 0 to 5.5 bar For use with CFC, HCFC and HFC refrigerants

Technical data and ordering

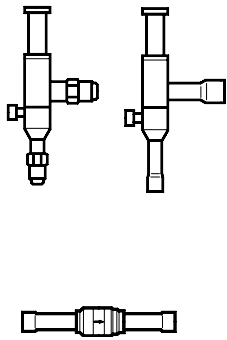

Condensing pressure regulator

Type	Evaporator capacity								Flare connection ²⁾³⁾		Code no. ⁴⁾	Solder connection ³⁾		Code no. ⁴⁾
	Rated liquid capacity in kW ¹⁾				Rated hot gas in kW ¹⁾				in.	mm		in.	mm	
	R22	R134a	R404A/ R507	R407C	R22	R134a	R404A/ R507	R407C						
KVR 12	50.4	47.3	36.6	54.4	13.2	11.6	12.0	14.3	1/2	12	034L0091	1/2	12	034L0093
KVR 15									3/8	16	034L0092	3/8	16	034L0097
KVR 22									7/8	22	034L0094			
KVR 28	129	121	93.7	139.3	34.9	30.6	34.9	37.7				1 1/8	28	034L0095
KVR 35												1 3/8	35	034L0100
NRD											1/2	12	020-1132	
												12	020-1136	

¹⁾ Rated capacity is the capacity of the regulator at

- Evaporating temperature $t_e = -10^\circ\text{C}$,
- Condensing temperature $t_c = +30^\circ\text{C}$
- Pressure drop in regulator $\Delta p =$
 - liquid line $\Delta p = 0,2$ bar
 - hotgas line $\Delta p = 0,4$ bar
 - offset = 3 bar

²⁾ Supplied without flare nuts. Separate flare nuts can be supplied:
 1/2 in./12 mm, code no. **011L1103**, 3/8 in./16 mm, code no. **011L1167**.

³⁾ The connection dimensions chosen must not be too small, since gas velocities in excess of 40 m/s at the inlet of the regulator can give flow noise.

⁴⁾ Code numbers in bold are normally on stock and a shorter delivery time can therefore be expected.

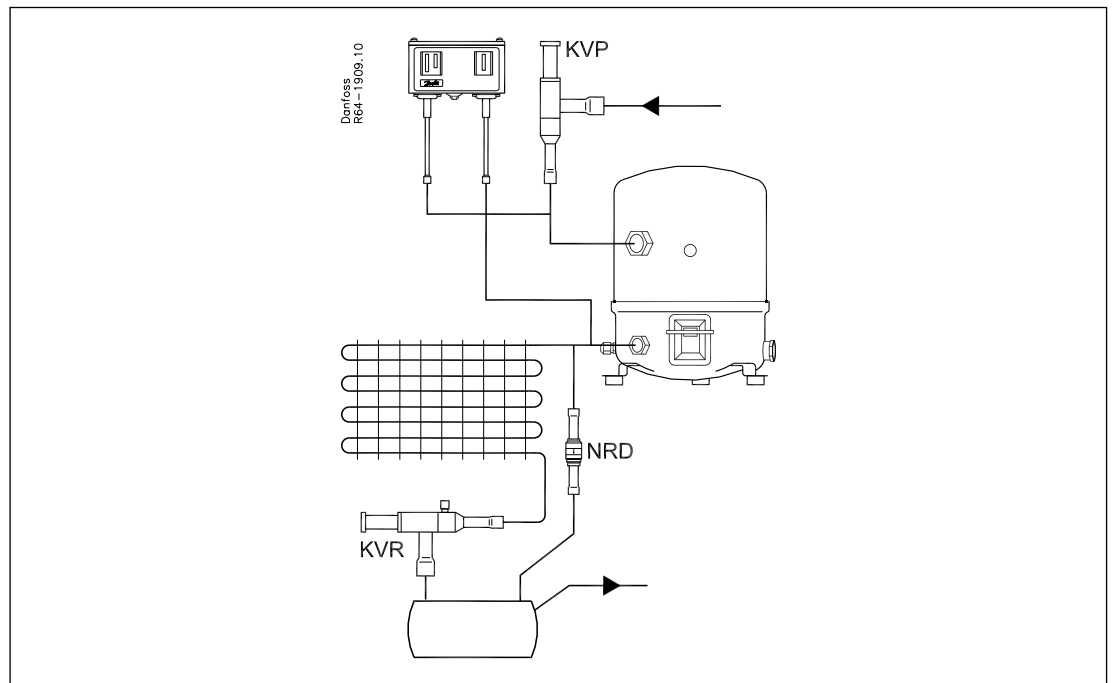



KVL compressor overload protection

Crankcase pressure regulator type KVL is fitted into the suction line ahead of the compressor. The KVL protects the compressor motor against overload during start-up after long standstill period or after defrost periods (high pressure in evaporator).

Features

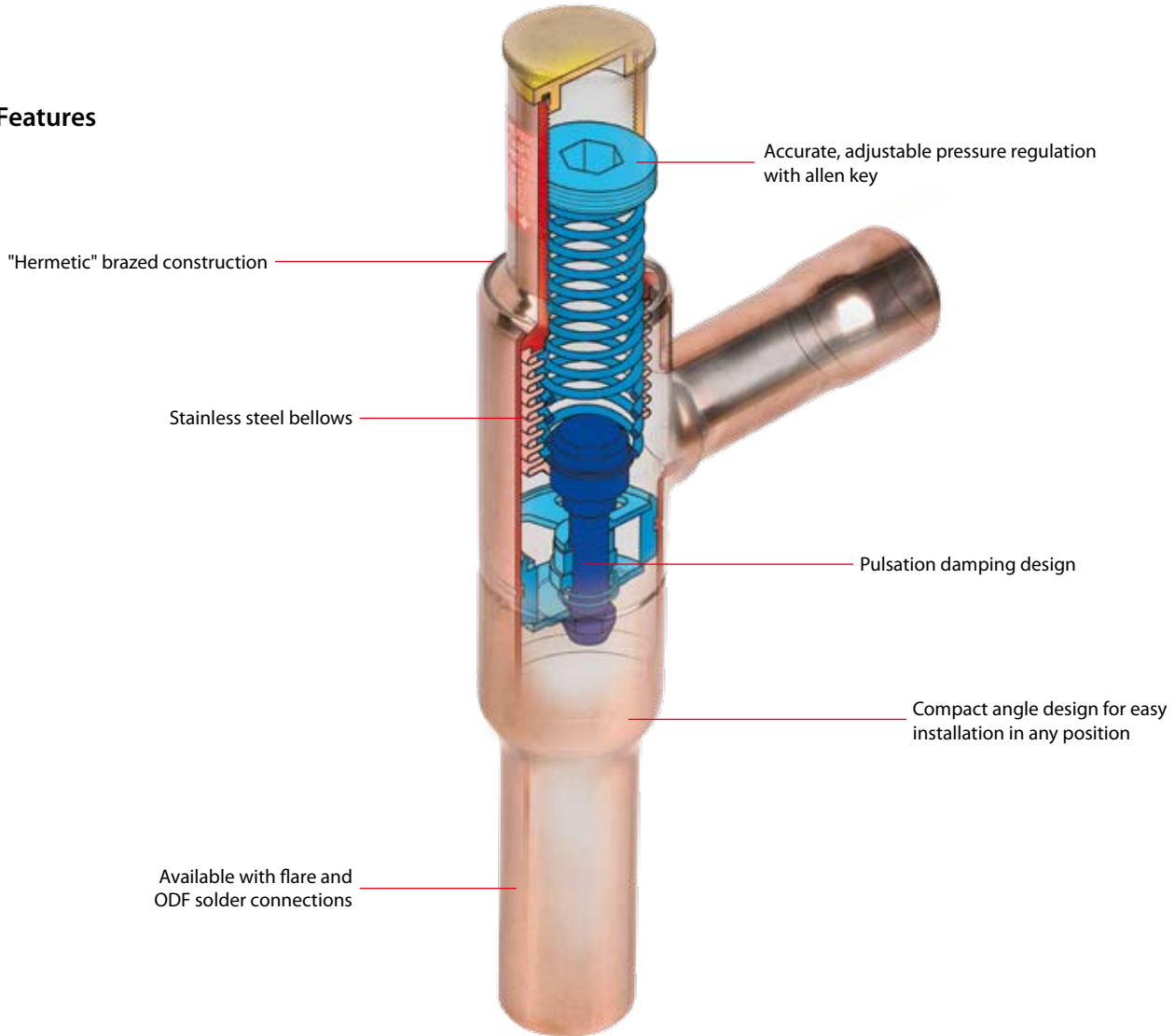

Applications	Advantages	Facts
<ul style="list-style-type: none"> · Traditional refrigeration · Air conditioning units · Transport refrigeration 	<ul style="list-style-type: none"> · Unaffected by ambient pressure variations · Bellows welded to the body for long lifetime · Accurate, adjustable pressure regulation · Easy adjustment before start up 	<ul style="list-style-type: none"> · Wide capacity and operating range · Regulation range: 0.2 to 6 bar · For use with CFC, HCFC and HFC refrigerants

Technical data and ordering

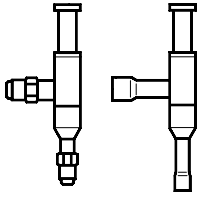

Cranksheet pressure regulator

Type	Rated capacity in kW ¹⁾				Flare connection ²⁾³⁾		Code no. ⁴⁾	Solder connection ³⁾		Code no. ⁴⁾
	R22	R134a	R404A/R507	R407C	in.	mm		in.	mm	
KVL 12	7.1	5.3	6.3	6.4	1/2	12	034L0041	1/2		034L0043
									12	
KVL 15	7.1	5.3	6.3	6.5	5/8	16	034L0042	5/8	16	034L0049
KVL 22	7.1	5.3	6.3	6.5				7/8	22	034L0045
KVL 28	17.8	13.2	15.9	16.4				1 1/8		034L0046
									28	
KVL 35	17.8	13.2	15.9	16.4				1 3/8	35	034L0052

¹⁾ Rated capacity is the capacity of the regulator at
 - Evaporating temperature $t_e = -10^\circ\text{C}$,
 - Condensing temperature $t_c = +25^\circ\text{C}$
 - Pressure drop in regulator $\Delta p = 0.2 \text{ bar}$

²⁾ Supplied without flare nuts. Separate flare nuts can be supplied:
 1/2 in./12 mm, code no. **011L1103**, 5/8 in./16 mm, code no. **011L1167**.

³⁾ The connection dimensions chosen must not be too small, since gas velocities in excess of 40 m/s at the inlet of the regulator can give flow noise.

⁴⁾ Code numbers in bold are normally on stock and a shorter delivery time can therefore be expected.

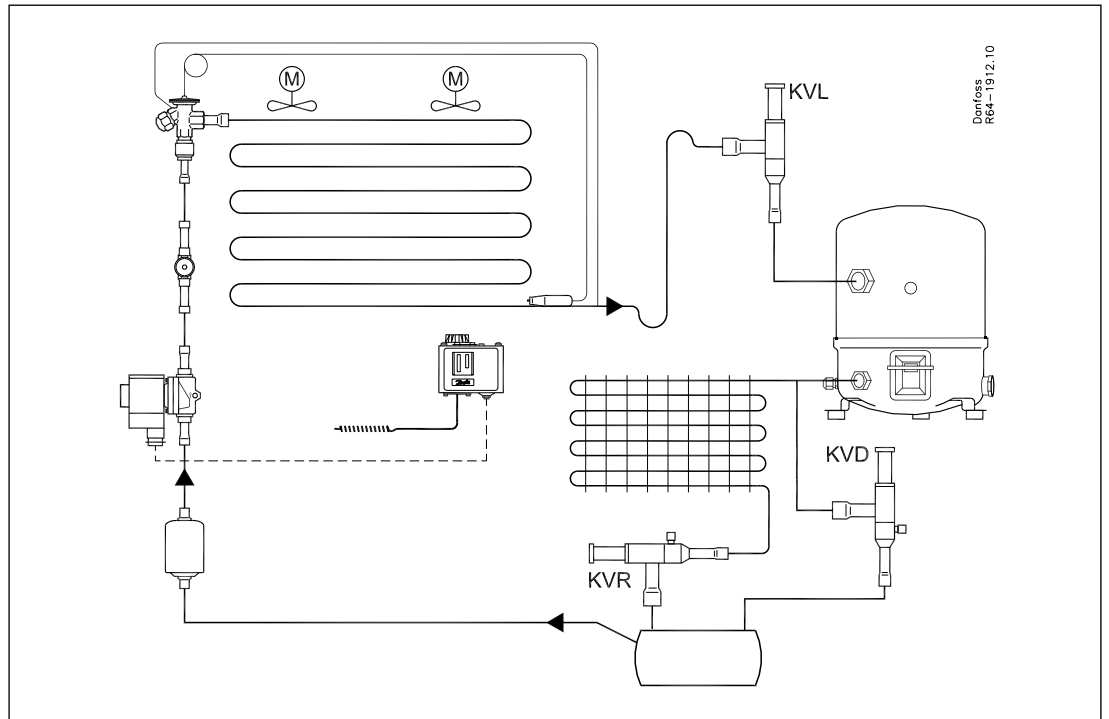



KVD Receiver pressure regulator

KVD is a modulating pressure regulator. It opens on falling receiver pressure and bypasses hot gas to maintain the receiver pressure at the regulator setting (adjustable). KVD and KVR form a regulating system, used to maintain constant and adequately high condensing and receiver pressure in plant with heat-recovery, and in refrigeration and air conditioning plant with air-cooled condensers.

Features

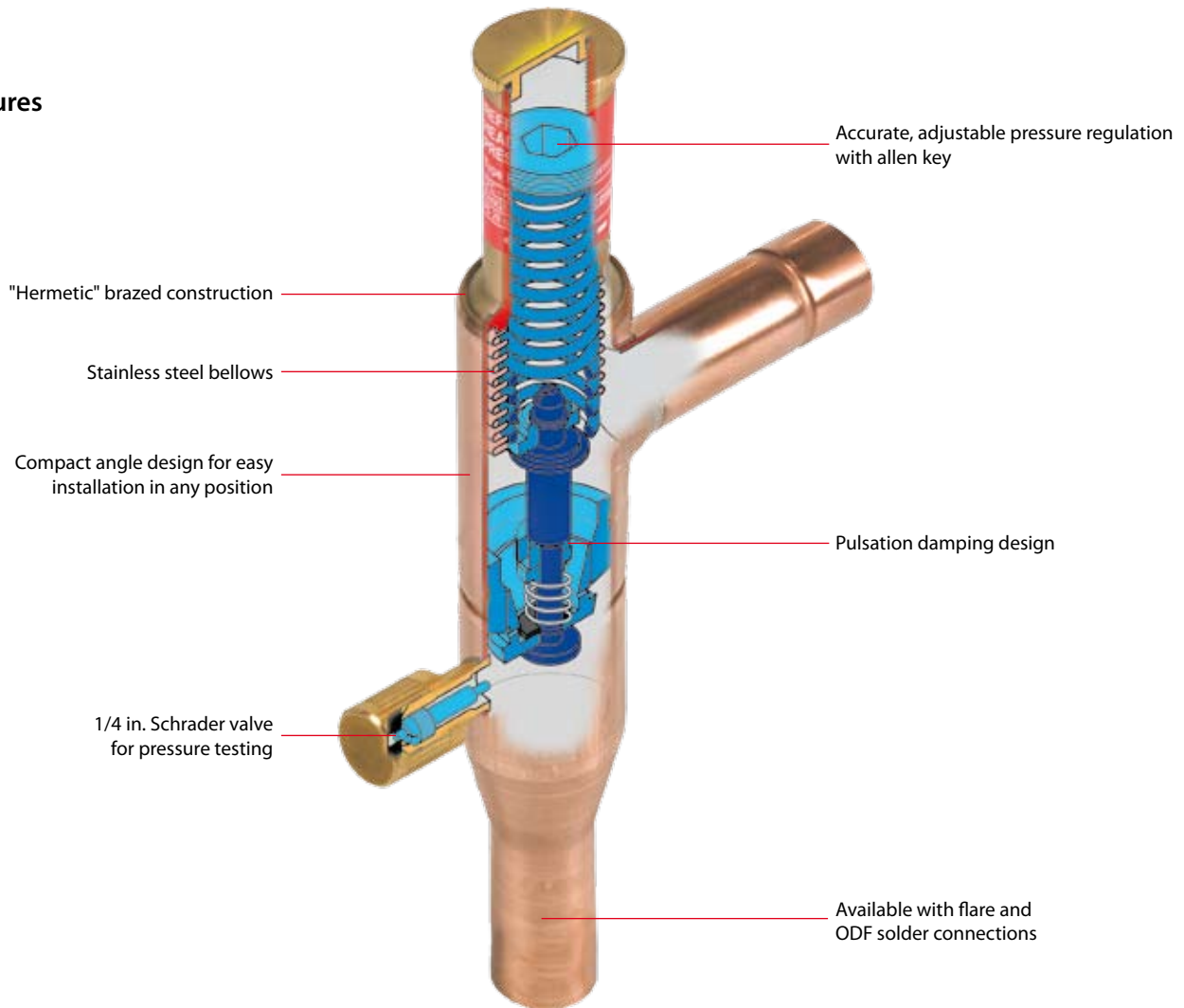

Applications	Advantages	Facts
<ul style="list-style-type: none"> Traditional refrigeration Air conditioning units 	<ul style="list-style-type: none"> The regulator is equipped with an effective damping device (9) against pulsations which can normally arise in a refrigeration plant. KVD regulations is only dependent upon the outlet pressure. Pressure variations on the inlet side of the regulator do not affect the degree of opening since KVD is equipped with an equalization bellows. 	<ul style="list-style-type: none"> Wide capacity and operating range Regulation range: 3 to 20 bar Max. working pressure PS = 28 bar Can be used as a relief valve from high pressure to suction side For use with CFC, HCFC and HFC refrigerants

Technical data and ordering

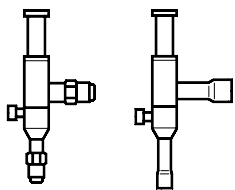

Receiver pressure regulators

Type	k, value m ³ /h ¹⁾	Flare connection ^{2) 3)}		Code no.	Solder connection ³⁾		Code no.
		in.	mm		in.	mm	
KVD 12	1.75	1/2	12	034L0171	1/2		034L0173
	1.75					12	
KVD 15	1.75	5/8	16	034L0172	5/8	16	034L0177

¹⁾ The k, value is the flow of water in m³/h at a pressure drop across valve of 1 bar, $\rho = 1000 \text{ kg/m}^3$.

²⁾ Supplied without flare nuts. Separate flare nuts can be supplied: 1/2 in./12 mm, code no. **011L1103**, 5/8 in./16 mm, code no. **011L1167**.

³⁾ The connection dimensions chosen must not be too small, since gas velocities in excess of 40 m/s at the inlet of the regulator can give flow noise.

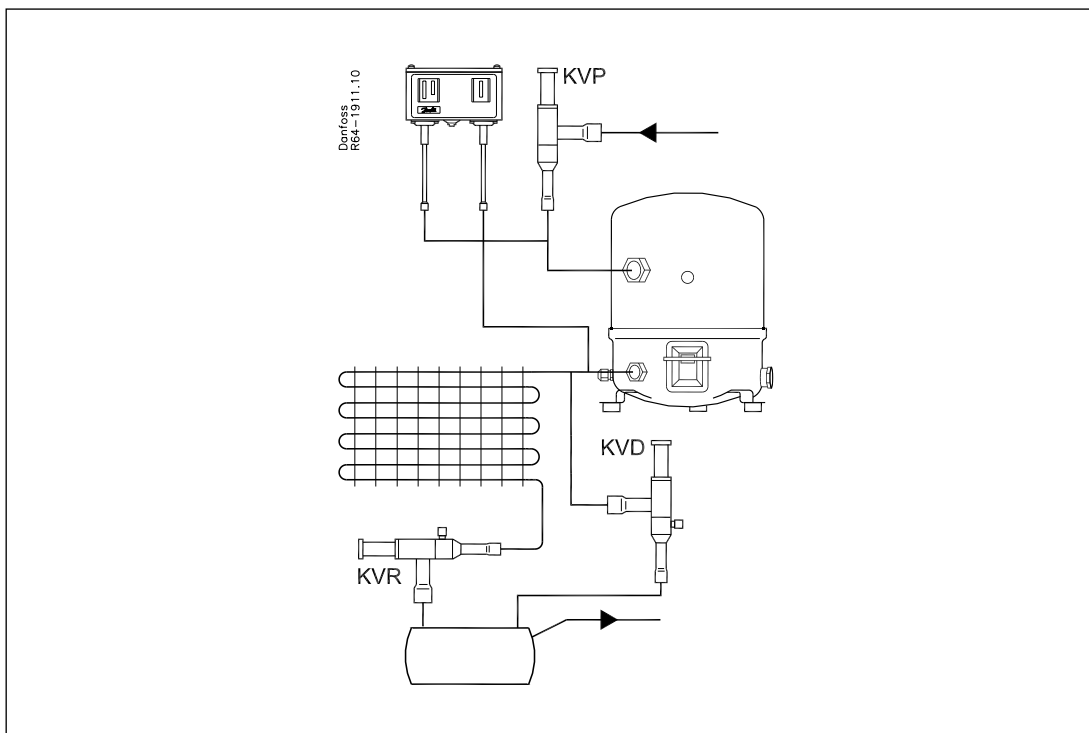



KVC Capacity regulator

KVC is a capacity regulator used for the adaption of the compressor capacity to the actual evaporator load. Placed in a bypass between high- and low pressure sides of the refrigeration system, KVC imposes a lower limit on the compressor suction pressure by supplying the low pressure side with replacement capacity in the form of hot gas/cool gas from the high pressure side.

Features

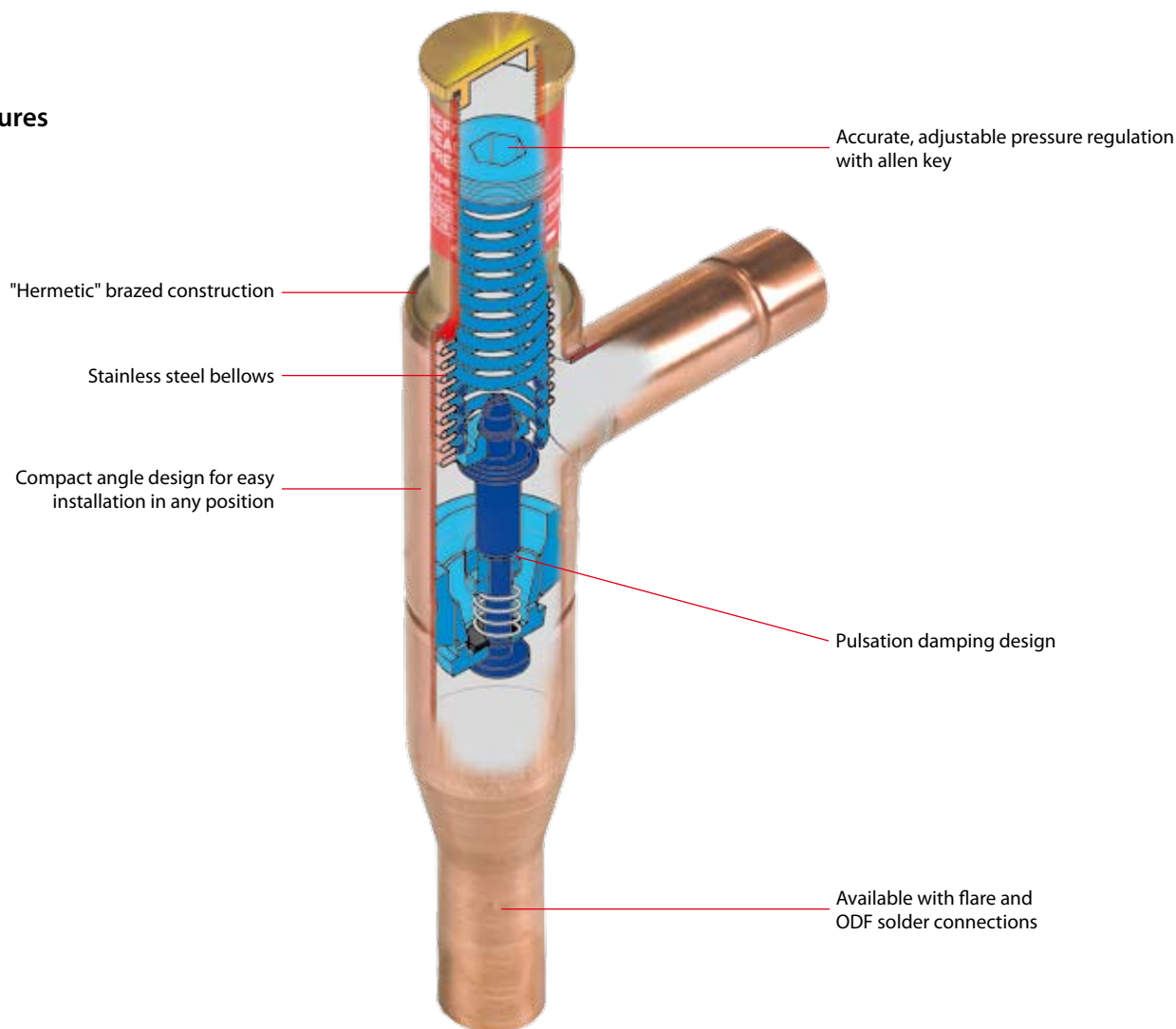

Applications	Advantages	Facts
<ul style="list-style-type: none"> · Traditional refrigeration · Air conditioning units · Transport refrigeration 	<ul style="list-style-type: none"> · KVC regulations is only dependent upon the outlet pressure. Pressure variations on the inlet side of the regulator do not affect the degree of opening since KVC is equipped with an equalization bellows. · The regulator is also equipped with an effective damping device against pulsations which can normally arise in a refrigeration plant. 	<ul style="list-style-type: none"> · Wide capacity and operating range · Regulation range: 0,2 to 6 bar · <i>Maximum working pressure</i> PS = 28 bar · The damping device to ensure long life for the regulator · For use with CFC, HCFC and HFC refrigerants

Technical data and ordering

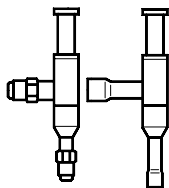

Capacity regulators

Type	Rated capacity in kW ⁴⁾				Flare connection ¹⁾²⁾		Code no.	Solder connection ²⁾		Code no.
	R22	R134a	R404A/R507	R407C	in.	mm		in.	mm	
KVC 12 ³⁾	7.6	4.8	6.9	8.4	1/2	12	034L0141	1/2	12	034L0143
KVC 15 ³⁾	14.9	9.4	13.6	16.4	5/8	16	034L0142	5/8	16	034L0147
KVC 22 ³⁾	19.1	12.0	17.4	21.0				7/8	22	034L0144

¹⁾ Supplied without flare nuts. Separate flare nuts can be supplied:
 1/2 in./12 mm, code no. **011L1103**, 5/8 in./16 mm, code no. **011L1167**.

²⁾ The connection dimensions chosen must not be too small, since gas velocities in excess of 40 m/s at the inlet of the regulator can give flow noise.

³⁾ If the discharge tube temperature becomes too high in relation to the compressor specification, the installation of an injection valve in a bypass between liquid line and compressor suction line is recommended.

⁴⁾ Rated capacity is the capacity of the regulator at:
 - Evaporating temperature $t_e = -10^\circ\text{C}$,
 - Condensing temperature $t_c = +25^\circ\text{C}$

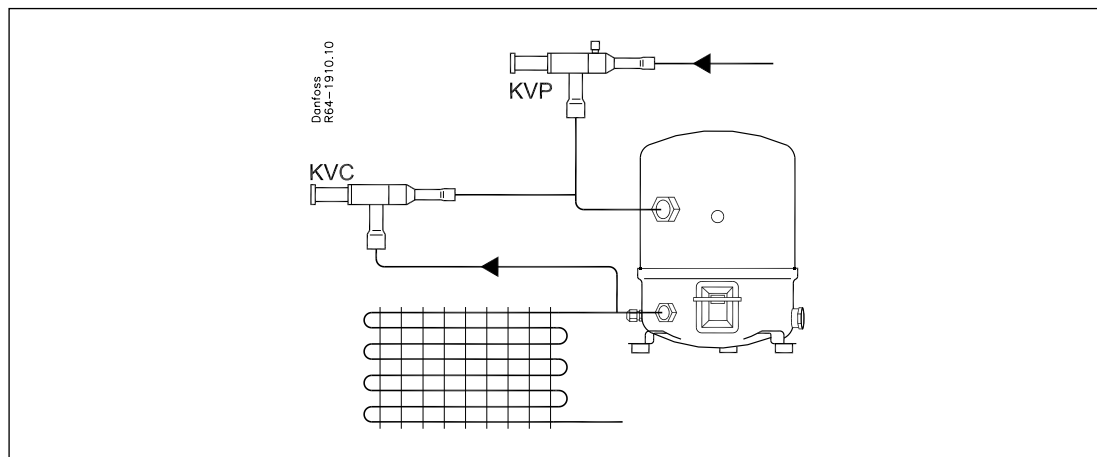



CPCE capacity regulator

CPCE capacity regulators adapt compressor capacity to actual evaporator load. They are designed for installation in a bypass line between the low and high pressure sides of the refrigeration system, for hot gas injection between evaporator and thermostatic expansion valve. Injection should be arranged to occur through an LG liquid-gas mixer.

Features

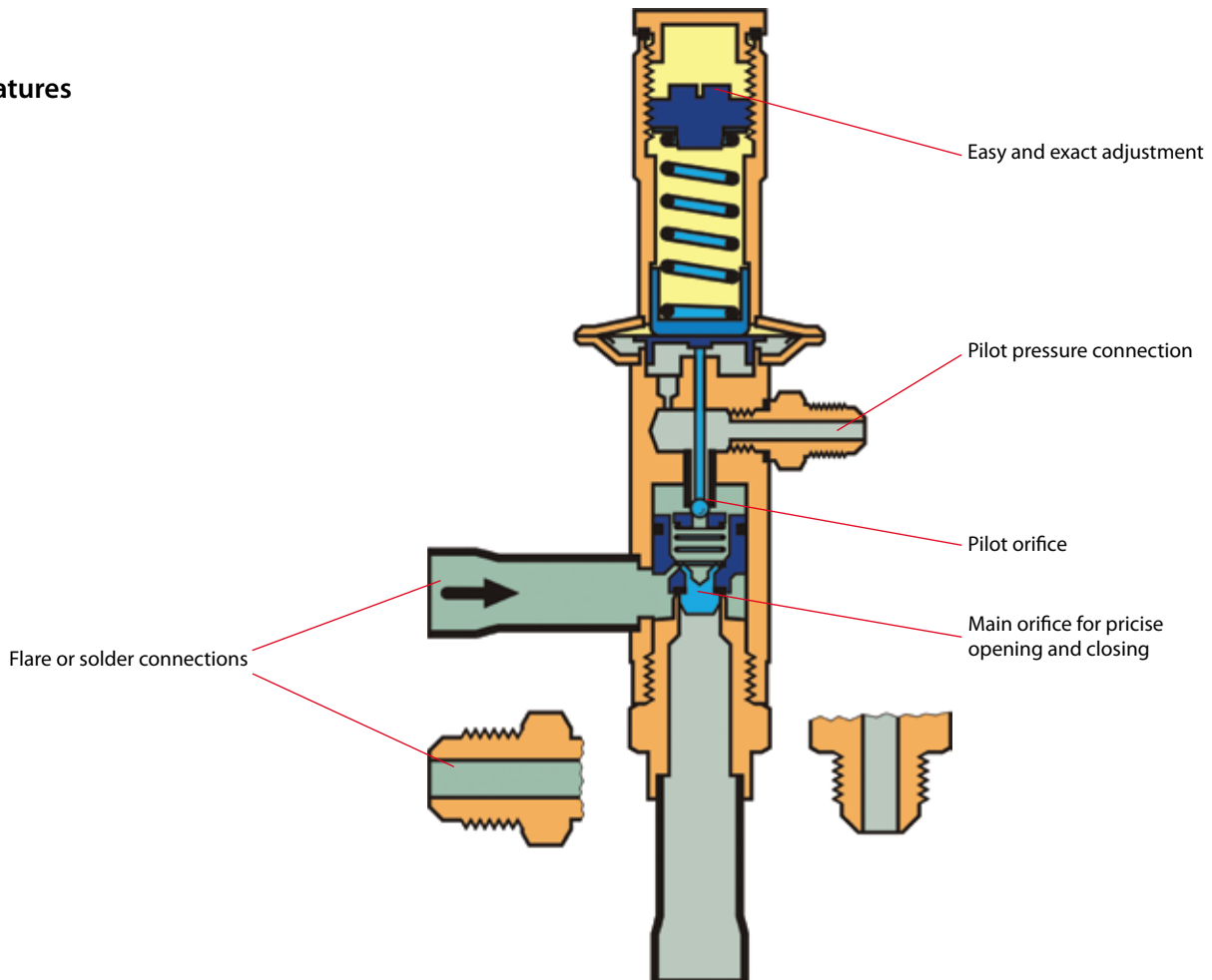

Applications	Advantages	Facts
<ul style="list-style-type: none"> Traditional refrigeration Air conditioning units 	<ul style="list-style-type: none"> Avoids high suction superheats by combining hot gas injection with expansion valve characteristics Protection against too low an evaporating temperature, i.e. avoids evaporator icing LG can be used for hot gas defrosting or reverse cycle systems 	<ul style="list-style-type: none"> The regulator increases evaporator gas velocity thus ensuring better oil return to compressor Direct connection to system suction line regulates hot gas injection independent of evaporator pressure drop LG provides homogenous mixing of the liquid and hot gas refrigerant injected into the evaporator Can be used for CFC, HCFC and HFC refrigerants Max. working pressure PS = 28 bar

Technical data and ordering

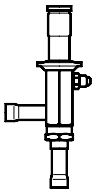

Capacity regulators

Type	Rated capacity in kW ¹⁾				Flare connection		Solder connection		Code no.
	R22	R134a	R404A/R507	R407C	in.	mm	in.	mm	
CPCE 12	17.4	7.9	16.4	19.0	½	12			034N0081
CPCE 12	17.4	7.9	16.4	19.0			½	12	034N0082
CPCE 15	25.6	11.6	24.2	27.9			⅝	16	034N0083
CPCE 22	34.0	15.2	32.0	37.1			⅞	22	034N0084

¹⁾ Rated capacity is the capacity of the regulator at:
 – Evaporating temperature $t_e = -10^\circ\text{C}$,
 – Condensing temperature $t_c = +30^\circ\text{C}$
 – Reduction of suction temperature/pressure $\Delta t_s = \text{CPCE}: 4 \text{ K}$.



Liquid-gas mixer

Type	Connection						Code no.
	Expansion valve ODM		Hot gas ODF		Liquid distributor ODF		
	in.	mm	in.	mm	in.	mm	
LG 12-16	⅝	16	½	12	⅝	16	069G4001
LG 12-22	⅞	22	½	12	⅞	22	069G4002
LG 16-28	1½	28	⅝	16	1½	28	069G4003
LG 22-35	1¾	35	⅞	22	1¾	35	069G4004

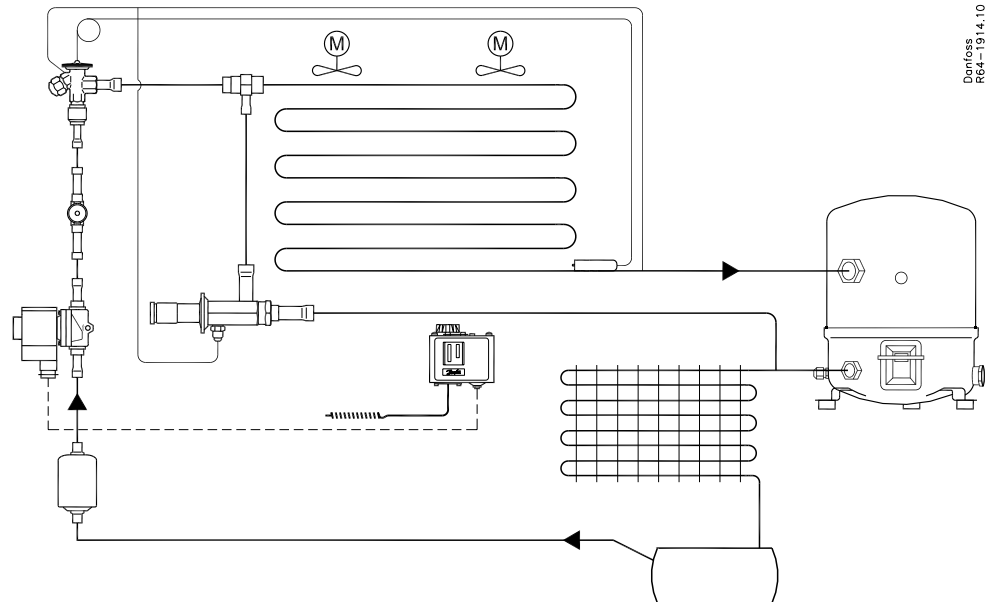

DocRef: R64-1314.10



Modularity, flexibility and unique features

Danfoss' extensive experience has been used to create a new valve concept which sets new and improved standards with respect to the demands required from control and injection valves. ICM valves are manufactured with a series of unique features.

Features

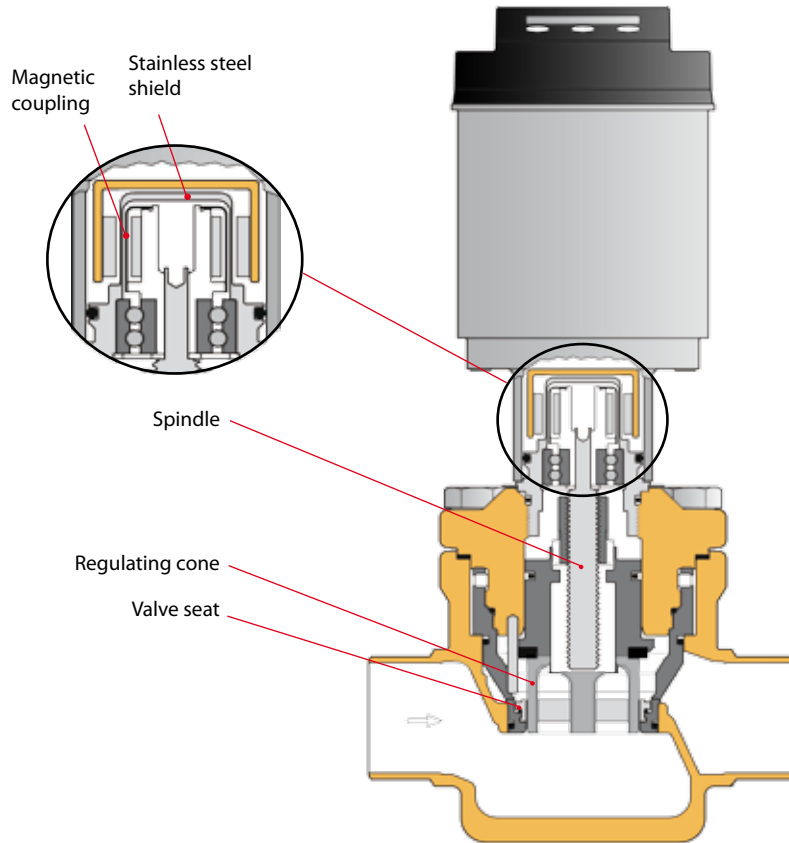

Advantages and features

- Designed for industrial refrigeration applications for a maximum working pressure of 52 bar/754 psig.
- Modular Concept
 - Each valve body is available with several different connection types and sizes
 - Valve overhaul is performed by replacing the function module
 - Possible to convert ICM motor valve to ICS servo valve.
- Low weight and compact design.
- Low temperature steel body
- Direct coupled connections
Connection types include butt weld, socket weld, solder and threaded connections.
- V-port regulating cone ensures optimum regulating accuracy particularly at part load.
- Manual opening possible via ICAD or Multifunction tool.
- Cavitation resistant valve seat.
- Magnet coupling - real hermetic sealing.

Facts

- Refrigerants:
Applicable to all common refrigerants including R717 and R744 (CO₂) and non-corrosive gases/liquids.
Use with flammable hydrocarbons cannot be recommended; please contact Danfoss.
- Temperature range
-60/+120°C (-76/+248°F).
- Surface protection
The external surface is zinc-chromated to provide good corrosion protection.
- Pressure range
The valve is designed for:
Max. working pressure: 52 bar g (754 psig)
- Max. opening pressure differential (MOPD)
 - ICM 20-32: 52 bar (750 psi)
 - ICM 40: 40 bar (580 psi)
 - ICM 50: 30 bar (435 psi)
 - ICM 65: 20 bar (290 psi)

The ICM concept

The ICM concept is developed around a modular principle. This gives the possibility of combining function modules and top covers with valve bodies, which are available in many different sizes and with a variety of connection possibilities.

The valve body



There are six valve bodies available.

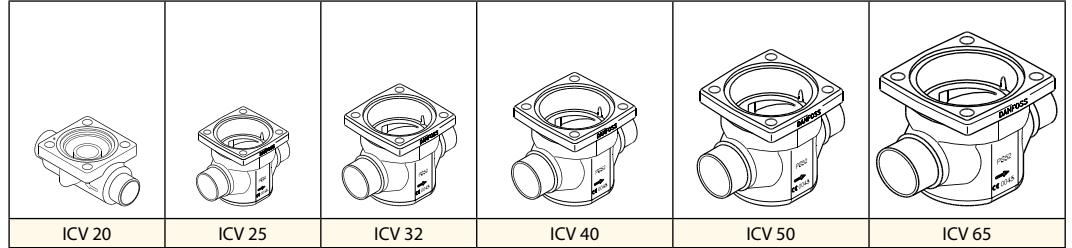

Each valve body is available with a range of undersized through oversized connection sizes and types.

D	A	J	SOC	SD	SA	FPT
Butt-weld DIN	Butt-weld ANSI	Butt-weld JIS	Socket weld ANSI	Solder DIN	Solder ANSI	Female Pipe Thread

The function module / top cover



Each body may be fitted with multiple function module / top cover to give different capacities.

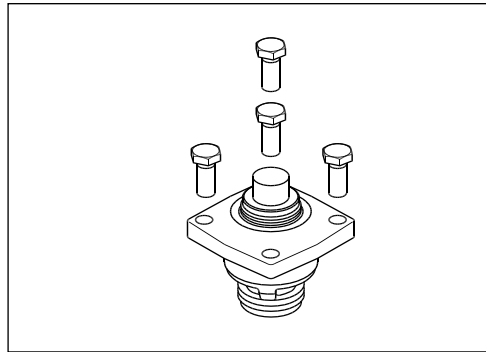

Type	Valve body size	K_v (m ³ /h)	C_v (USgal/min)
ICM20-A	20	0.6	0.7
ICM20-B		2.4	2.8
ICM20-C		4.6	5.3
ICM25-A	25	6	7.0
ICM25-B		12	13.9
ICM32-A	32	9	10.4
ICM32-B		17	20
ICM40-A	40	15	17
ICM40-B		26	30
ICM50-A	50	23	27
ICM50-B		40	46
ICM65-B	65	70	81

The actuator



A magnetic coupled actuator is easily installed. Two actuators cover the entire ICM program

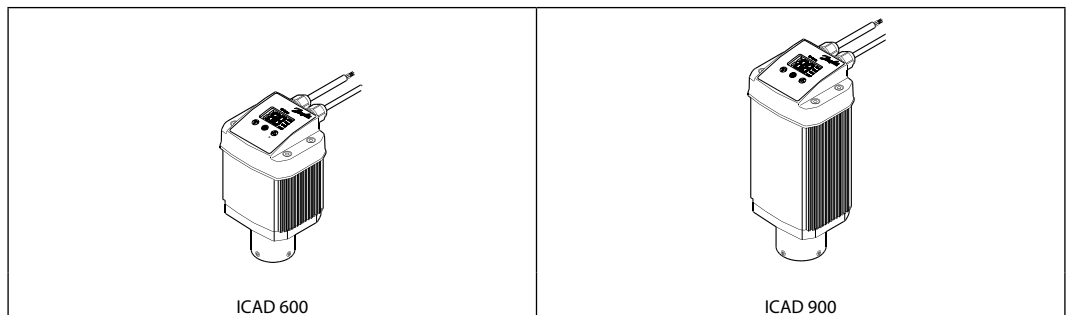

Quick selection of ICM valves

Suction line (capacity in kW)

Type		Refrigerant								K _v value (m ³ /h)
		R 717		R 744		R 407C		R 404A		
		-40°C	-10°C	-50°C	-30°C	-5°C	5°C	-40°C	-10°C	
		Δp bar								
		0.1	0.2	0.2	0.2	0.2	0.2	0.1	0.2	
ICM 20-A	DN20	1.4	4	2.1	3.1	1.65	2.4	0.45	1.3	0.6
ICM 20-B		5.6	16.2	8.3	12	6.5	7.6	1.8	5	2.4
ICM 20-C		10.8	31	16	23	12.5	14.2	3.4	10	4.6
ICM 25-A	DN25	14.1	40	21	31	16.5	18.5	4.5	13	6
ICM 25-B		28.2	81	42	61	31	37	9	26	12
ICM 32-A	DN32	21.2	61	31	46	23	28	6.5	19	9
ICM 32-B		40	115	59	86	43	52	12.5	36	17
ICM 40-A	DN40	35.3	101	52	76	37	46	11	32	15
ICM 40-B		61.2	175	90	132	65	79	19	56	26
ICM 50-A	DN50	54	155	80	117	57	70	16.5	49	23
ICM 50-B		94	270	138	203	99	122	30	86	40
ICM 65-B	DN65	164	472	241	355	174	213	51	150	70

Liquid line (capacity in kW)

Type		Refrigerant								K _v value (m ³ /h)
		R 717		R 744		R 407C		R 404A		
		-40°C	-10°C	-50°C	-30°C	-5°C	5°C	-40°C	-10°C	
		Δp bar								
		0.2	0.2	0.2	0.2	0.2	0.2	0.2	0.2	
ICM 20-A	DN20	62	64	15	15.4	13.5	13.9	7.2	9	0.6
ICM 20-B		249	255	60	62	54	56	29	34	2.4
ICM 20-C		478	489	115	118	103	107	55	65	4.6
ICM 25-A	DN25	624	638	150	154	135	139	72	85	6
ICM 25-B		1248	1277	300	308	270	278	143	170	12
ICM 32-A	DN32	936	958	225	231	202	208	107	128	9
ICM 32-B		1769	1809	425	436	381	393	203	241	17
ICM 40-A	DN40	1561	1596	375	385	337	347	179	213	15
ICM 40-B		2705	2767	650	667	584	602	310	369	26
ICM 50-A	DN50	2393	2447	575	590	516	532	274	327	23
ICM 50-B		4162	4256	1000	1026	898	926	477	568	40
ICM 65-B	DN65	7284	7449	1750	1796	1571	1654	835	994	70

Hot gas line (capacity in kW)

Type		Refrigerant								K _v value (m ³ /h)
		R 717		R 744		R 407C		R 404A		
		-40°C	-10°C	-50°C	-30°C	-5°C	5°C	-40°C	-10°C	
		Δp bar								
		0.2	0.2	0.2	0.2	0.2	0.2	0.2	0.2	
ICM 20-A	DN20	6.4	6.9	3.8	4.2	2.97	3.3	1	2	0.6
ICM 20-B		25	28	15.5	17	12.2	11	6	7	2.4
ICM 20-C		48	53	29	32	19.9	21	11	13	4.6
ICM 25-A	DN25	64	69	38	41	26	27	15	18	6
ICM 25-B		126	139	76	83	52	54	29	35	12
ICM 32-A	DN32	95	104	57	62	39	41	22	26	9
ICM 32-B		180	196	108	117	73	77	42	50	17
ICM 40-A	DN40	157	173	95	104	65	68	37	44	15
ICM 40-B		272	300	165	180	112	119	64	76	26
ICM 50-A	DN50	240	266	146	159	99	105	56	67	23
ICM 50-B		420	462	254	276	172	182	98	117	40
ICM 65-B	DN65	735	809	443	484	302	309	172	205	70

Conditions: R717, R404A, R407C: t_{liq} = 30°C, R744: t_{liq} = 10°C

Please note:

For proper selection of the ICM motor valve Danfoss recommend that you use the technical leaflet (DKRCI.PD.HT0.A) or the Danfoss calculation Software DIRCalc™. The software is free of charge. Please contact your local Danfoss sales office.

Ordering the ICM valve

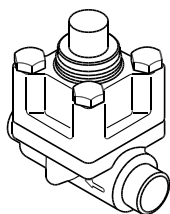

ICM 20

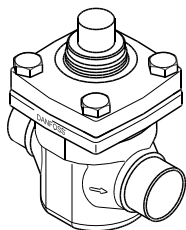

ICM 25-65

Type		ICM 20-A	ICM 20-B	ICM 20-C	ICM 25-A	ICM 25-B	ICM 32-A	ICM 32-B
		Operates with ICAD 600 actuator (not included)						
Connection		Code no.	Code no.	Code no.	Code no.	Code no.	Code no.	Code no.
Butt-weld DIN	DN 20	027H1030	027H1031	027H1032				
	DN 25	027H1020	027H1021	027H1022	027H2000	027H2001		
	DN 32						027H3000	027H3001
	DN 40				027H2016		027H3012	
Solder DIN & ANSI	22 mm	027H1045	027H1046	027H1047	027H2006	027H2007		
	28 mm				027H2008	027H2009		
	35 mm				027H2014		027H3006	027H3007
	7/8" SA	027H1050	027H1051	027H1052	027H2010	027H2011		
	1 1/8" SA				027H2012	027H2013		
	1 3/8" SA						027H3006	027H3007
	1 5/8" SA						027H3008	027H3009

Type		ICM 40-A	ICM 40-B	ICM 50-A	ICM 50-B	ICM 65-B
		Operates with ICAD 900 actuator (not included)				
Connection		Code no.	Code no.	Code no.	Code no.	Code no.
Butt-weld DIN	DN 40	027H4000	027H4001			
	DN 50	027H4010		027H5000	027H5001	
	DN 65			027H5008		027H6001
Solder DIN & ANSI	42 mm	027H4008	027H4009			
	54 mm			027H5006	027H5007	
	76 mm					027H6009
	1 5/8" SA	027H4006	027H4007			
	2 1/8" SA			027H5006	027H5007	
2 5/8" SA					027H6007	

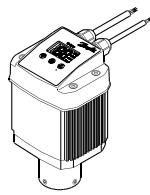

ICAD 600

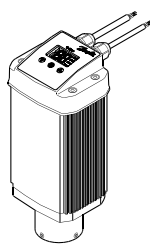

ICAD 900

Actuator type	Supply voltage	Load	Input	Output	Code no.
ICAD 600	24 V d.c.	1.2 A	0/4-20 mA	0/4-20 mA	027H1200
ICAD 900		2.0 A	0/2-10 V		027H1201



Service Tool	Functions	Code no.
for ICM 20-32	Featuring a magnetic coupling for manual operation of the ICM and a threaded end for dismantling of the ICS function module and other useful functions.	027H0180
for ICM 40-65		027H0181

Can be ordered as parts programme (separate ordering of valve body, function / top cover and actuator).
Please contact your local Danfoss sales company for more information.



Modularity, flexibility and unique features

Danfoss' extensive experience has been used to create a new valve concept which sets new and improved standards with respect to the demands required from control and injection valves. ICS valves are manufactured with a series of unique features.

Features

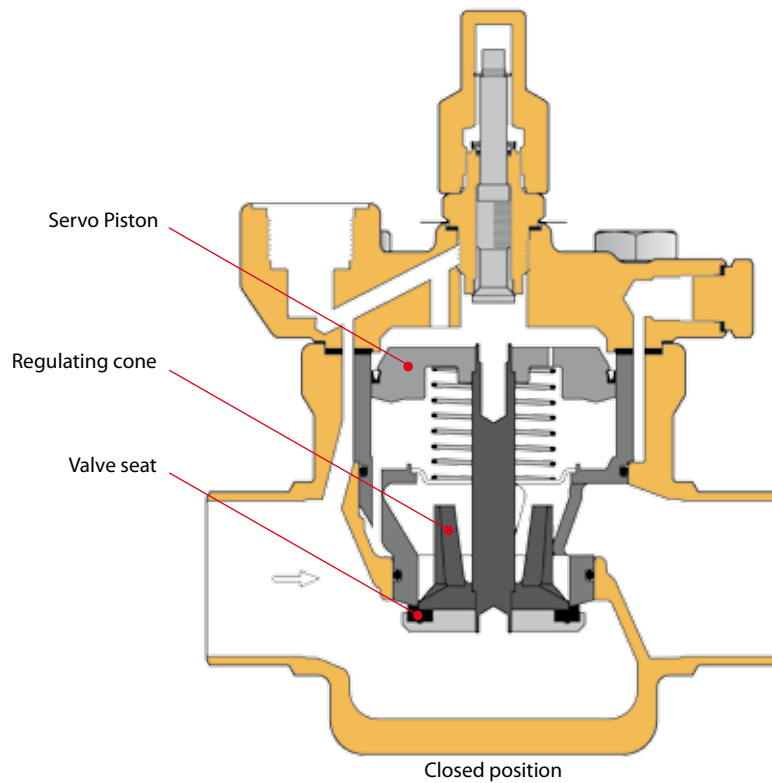

Advantages and features

- Designed for industrial refrigeration applications for a maximum working pressure of 52 bar/754 psig.
- Modular Concept
 - Each valve body is available with several different connection types and sizes
 - Valve overhaul is performed by replacing the function module
 - Possible to convert ICS servo to ICM motor valve
- Low weight and compact design.
- Low temperature steel body
- Direct coupled connections
Connection types include butt weld, socket weld, solder and threaded connections.
- V-port regulating cone ensures optimum regulating accuracy particularly at part load.
- Manual operating spindle.
- The ICS valve is a multifunction valve where 1 or up to 3 pilot valves can be mounted into the pilot ports.

Facts

- Refrigerants:
Applicable to all common refrigerants including R717 and R744 (CO₂) and non-corrosive gases/liquids.
Use with flammable hydrocarbons cannot be recommended; please contact Danfoss.
- Temperature range
-60/+120°C (-76/+248°F).
- Surface protection
The external surface is zinc-chromated to provide good corrosion protection.
- Pressure range
The valve is designed for:
Max. working pressure: 52 bar g (754 psig)

The ICS concept

The ICS concept is developed around a modular principle. This gives the possibility of combining function modules and top covers with valve bodies, which are available in many different sizes and with a variety of connection possibilities.

The valve body



There are five valve bodies available.

ICS 25	ICS 32	ICS 40	ICS 50	ICS 65

Each valve body is available with a range of undersized through oversized connection sizes and types.

D	A	J	SOC	SD	SA	FPT
Butt-weld DIN	Butt-weld ANSI	Butt-weld JIS	Socket weld ANSI	Solder DIN	Solder ANSI	Female Pipe Thread

The top cover



Each valve body may be fitted with a 1 pilot or 3 pilot top cover.

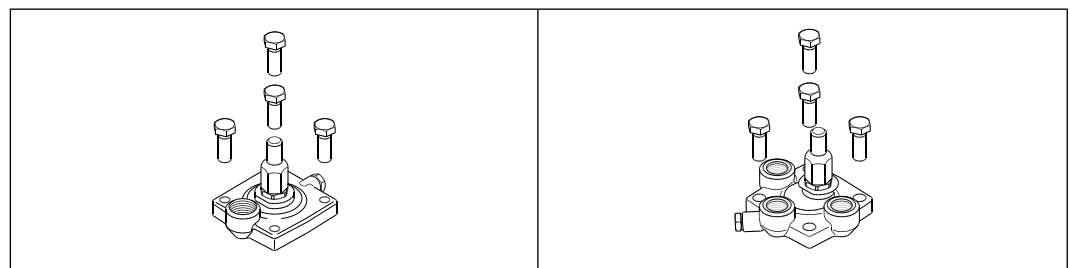

The function module



In ICS, multiple inserts (function modules) are available to give different capacities.

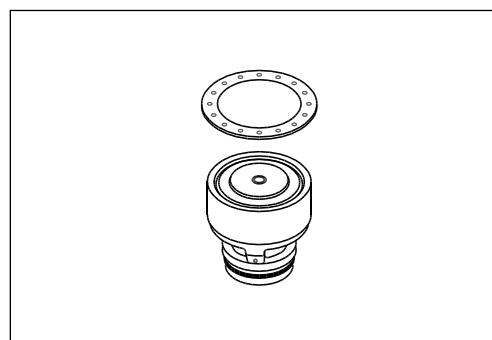

Type	Valve body size	K_v (m ³ /h)
ICS25-5	25	1.7
ICS25-10		3.5
ICS25-15		6.0
ICS25-20		8
ICS25-25		11.5
ICS32	32	17
ICS40	40	27
ICS50	50	44
ICS65	65	70

Quick selection of ICS valves

Suction line

Example:
 R407C - suction line
 $Q_o = 23 \text{ kW}$
 $t_o = 0^\circ\text{C}$

Result:
 Both ICS 25-20
 and ICS 25-25
 can be used.

Conditions:
 Evaporating temperature:
 R717 $t_o = -10^\circ\text{C}$
 R407C $t_o = 0^\circ\text{C}$
 R404A $t_o = -40^\circ\text{C}$

Condensing temperature:
 $t_c = +32^\circ\text{C}$
 $t_{liq} = +30^\circ\text{C}$

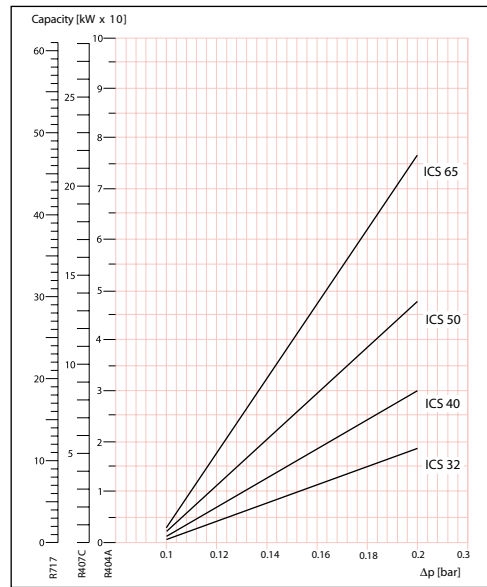
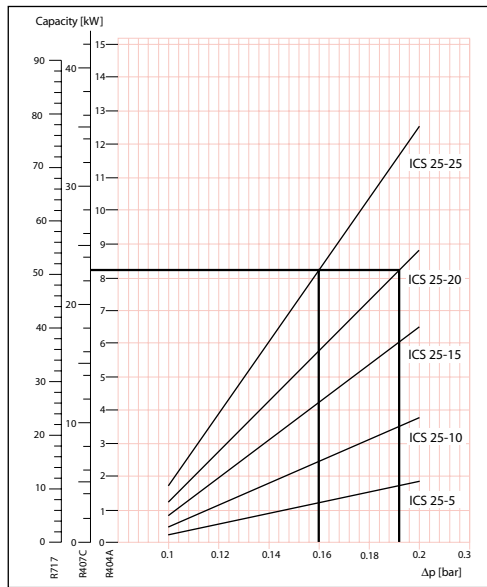

Liquid line

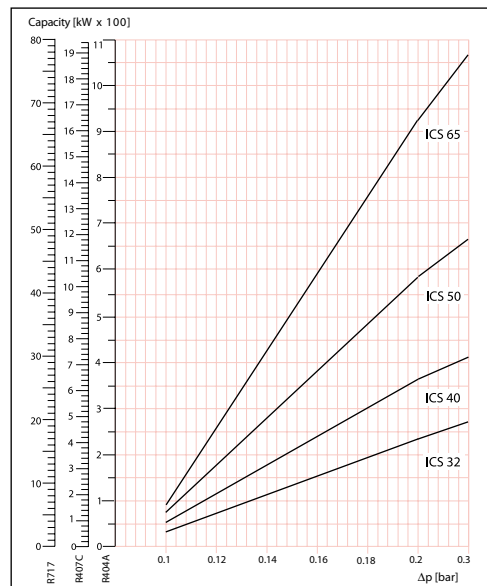
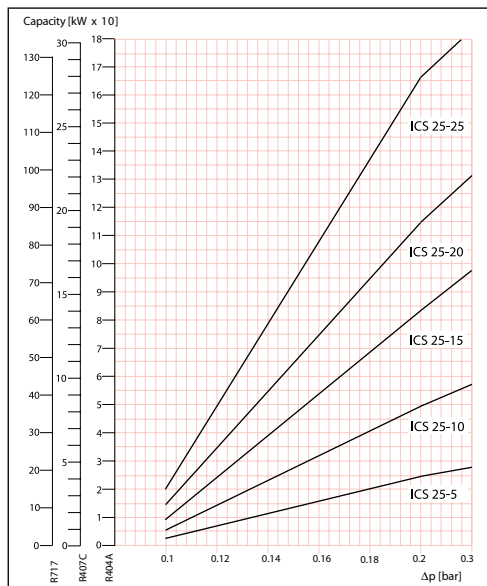

Hot gas line

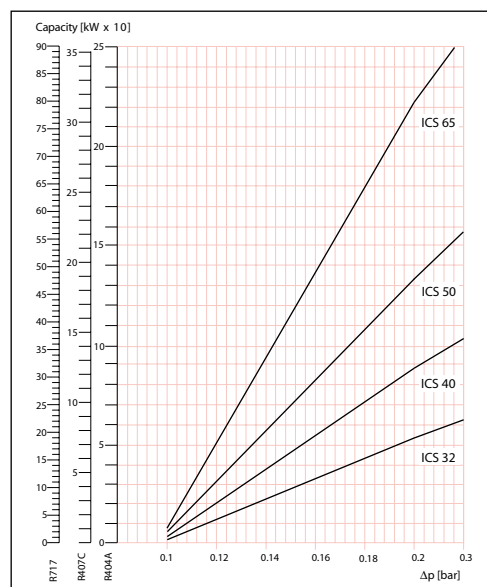
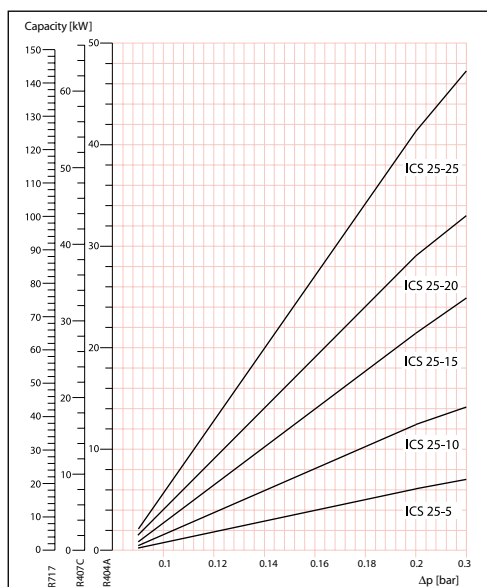

The capacities in the range 0.1 bar to 0.2 bars are approx. values.
 For proper selection of the ICS valve Danfoss recommend that you use the technical leaflet (DKRCI.PD.H50.A) or the Danfoss calculation Software DIRCalcTM. The software is free of charge. Please contact your local Danfoss sales office.

Ordering the ICS valve

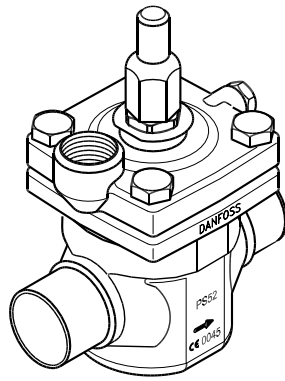

1 pilot

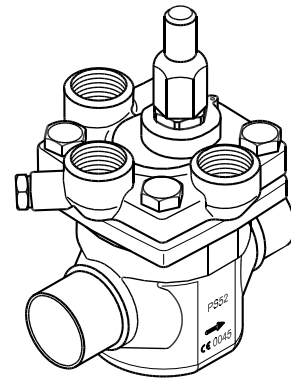

3 pilots

		Available connections							
		20 D (3/4 in.)	25 D (1 in.)	32 D (1 1/4 in.)	40 D (1 1/2 in.)	35 SD (1 3/8 in. SA)	28 SA (1 1/8 in.)	22 SA (7/8 in.)	28 SD (1 1/8 in.)
ICS 25-5	1 Pilot	027H2028	027H2020				027H2026	027H2025	027H2024
	3 Pilots	027H2078	027H2070				027H2076	027H2075	027H2074
ICS 25-10	1 Pilot	027H2038	027H2030				027H2036	027H2035	027H2034
	3 Pilots	027H2088	027H2080				027H2086	027H2085	027H2084
ICS 25-15	1 Pilot	027H2048	027H2040				027H2046	027H2045	027H2044
	3 Pilots	027H2098	027H2090				027H2096	027H2095	027H2094
ICS 25-20	1 Pilot	027H2058	027H2050				027H2056	027H2055	027H2054
	3 Pilots	027H2108	027H2100				027H2106	027H2105	027H2104
ICS 25-25	1 Pilot	027H2068	027H2060				027H2066	027H2065	027H2064
	3 Pilots	027H2118	027H2110				027H2116	027H2115	027H2114

		22 SD (7/8 in.)	20 A (3/4 in.)	25 A (1 in.)	32 A (1 1/4 in.)	20 SOC (3/4 in.)	25 SOC (1 in.)	20 FPT (3/4 in.)	25 FPT (1 in.)
ICS 25-5	1 Pilot	027H2023	027H2029	027H2021		027H2140			
	3 Pilots	027H2073	027H2079	027H2071		027H2145			
ICS 25-10	1 Pilot	027H2033	027H2039	027H2031		027H2141			
	3 Pilots	027H2083	027H2089	027H2081		027H2146			
ICS 25-15	1 Pilot	027H2043	027H2049	027H2041		027H2142			
	3 Pilots	027H2093	027H2099	027H2091		027H2147			
ICS 25-20	1 Pilot	027H2053	027H2059	027H2051		027H2143			
	3 Pilots	027H2103	027H2109	027H2101		027H2148			
ICS 25-25	1 Pilot	027H2063		027H2061			027H2062		
	3 Pilots	027H2113		027H2111			027H2112		

		Available connections							
		32 D (1 1/4 in.)	40 D (1 1/2 in.)	42 SA (1 5/8 in.)	42 SD (1 5/8 in.)	35 SD (1 3/8 in. SA)	32 A (1 1/4 in.)	32 SOC (1 1/4 in.)	40 A (1 1/2 in.)
ICS 32	1 Pilot	027H3020				027H3023	027H3021	027H3022	
	3 Pilots	027H3030				027H3033	027H3031	027H3032	

		Available connections						
		40 D (1 1/2 in.)	50 D (2 in.)	42 SA (1 5/8 in.)	42 SD (1 5/8 in.)	40 A (1 1/2 in.)	40 SOC (1 1/2 in.)	50 A (2 in.)
ICS 40	1 Pilot	027H4020		027H4024	027H4023	027H4021	027H4022	
	3 Pilots	027H4030		027H4034	027H4033	027H4031	027H4032	

		Available connections					
		50 D (2 in.)	65 D (2 1/2 in.)	54 SD (2 1/8 in. SA)	65 A (2 1/2 in.)	50 A (2 in.)	50 SOC (2 in.)
ICS 50	1 Pilot	027H5020		027H5023		027H5021	027H5022
	3 Pilots	027H5030		027H5033		027H5031	027H5032

		Available connections							
		65 D (2 1/2 in.)	65 A (2 1/2 in.)	65 SOC (2 1/2 in.)	80 D (3 in.)	80 A (3 in.)	67 SA (2 5/8 in.)	76 SD (3 in.)	65 J (2 1/2 in.)
ICS 65	1 Pilot	027H6020	027H6021	027H6023			027H6025	027H6024	
	3 Pilots	027H6030	027H6031	027H6033			027H6035	027H6034	

Can be ordered as parts programme (separate ordering of valve body, top cover and function module).
Please contact your local Danfoss sales company for more information.

ICS application examples

There are several combination possibilities; here you will see an overview of the most important ICS application possibilities.

<p>Example no. 1-1</p> <p>Constant pressure regulation. -0.66 to 7 bar g (19.5 in. Hg to 102 psig).</p>		<p>Products</p> <p>1 × ICS 1 Pilot 1 × CVP (LP)</p>	
<p>Example no. 1-2</p> <p>Differential pressure regulation. 0 to 7 bar g (0 to 102 psig).</p>		<p>Products</p> <p>1 × ICS 1 Pilot 1 × CVPP (LP)</p>	
<p>Example no. 1-5</p> <p>On/off regulation (solenoid valve).</p>		<p>Products</p> <p>1 × ICS 1 Pilot 1 × EVM 1 × coil</p>	
<p>Example no. 1-11</p> <p>Electronically controlled media temperature regulation. -1 to 8 bar g (0 in. Hg to 116 psig).</p>		<p>Products</p> <p>1 × ICS 1 Pilot 1 × CVQ</p>	
<p>Example no. 3-1</p> <p>Constant pressure regulation combined with electrical shut off. -0.66 to 7 bar g (19.5 in. Hg to 102 psig).</p>		<p>Products</p> <p>1 × ICS 3 Pilots 1 × blanking plug 1 × CVP (LP) 1 × EVM 1 × coil</p>	

The ICS valve will be fully open if the pilot valve in P is fully open, irrespective of the degree of opening of pilot valves SI and SII. The ICS valve will be fully closed if the pilot valve in P is fully closed and at least one of the valves in SI or SII is fully closed at the same time. The relation between the pilot valves in ports SI, SII and P is shown in the table below.

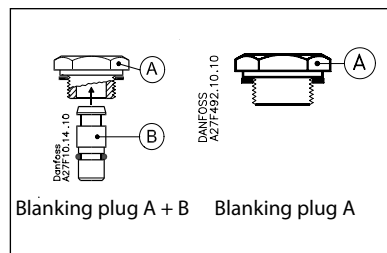
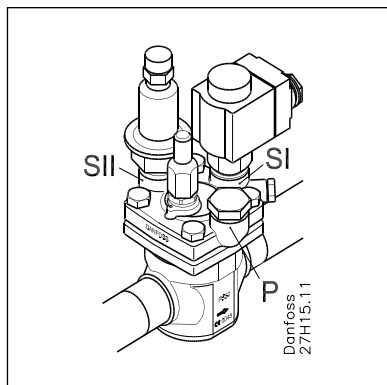

	Pilot valve port			ICS valve
	SI	SII	P	
Open	Open	Closed	Open	
Open	Open	Open	Open	
Open	Closed	Closed	Closed	
Open	Closed	Open	Open	
Closed	Open	Closed	Closed	
Closed	Open	Open	Open	
Closed	Closed	Closed	Closed	
Closed	Closed	Open	Open	

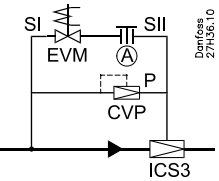
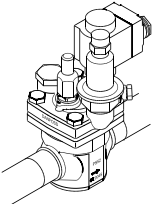
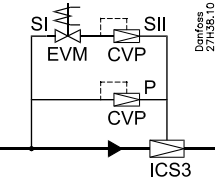
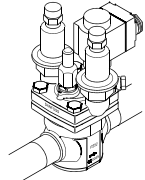
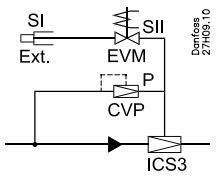
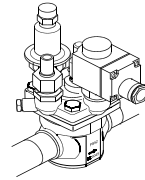
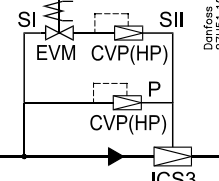
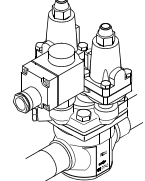
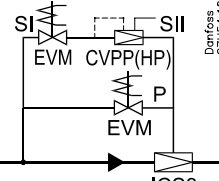
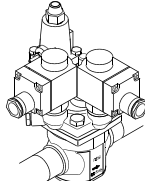
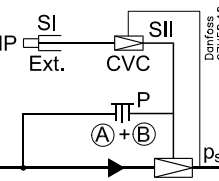
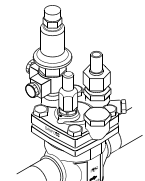
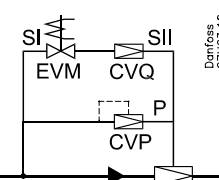
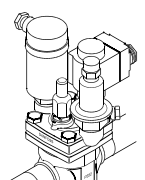
<p>Example no. 3-2</p> <p>Constant pressure regulation combined with electrical wide open. -0.66 to 7 bar g (19.5 in. Hg to 102 psig).</p>	 <p style="text-align: right;">Danfoss 27H06.10</p>	<p>Products</p> <ul style="list-style-type: none"> 1 × ICS 3 Pilots 1 × blanking plug 1 × CVP (LP) 1 × EVM 	
<p>Example no. 3-4</p> <p>Constant pressure regulation with change-over between two preset evaporating pressures. -0.66 to 7 bar g (19.5 in. Hg to 102 psig).</p>	 <p style="text-align: right;">Danfoss 27H051.10</p>	<p>Products</p> <ul style="list-style-type: none"> 1 × ICS 3 Pilots 2 × CVP (LP) 1 × EVM 1 × coil 	
<p>Example no. 3-5</p> <p>External control pressure with electrical shut off combined with constant pressure regulation. -0.66 to 7 bar g (19.5 in. Hg to 102 psig).</p>	 <p style="text-align: right;">Danfoss 27H09.10</p>	<p>Products</p> <ul style="list-style-type: none"> 1 × ICS 3 Pilots 1 × nipple for external control pressure 1 × CVP (LP) 1 × EVM 1 × coil 	
<p>Example no. 3-18</p> <p>Constant pressure regulation with change-over between two preset evaporating pressures. -0.66 to 28 bar g (19.5 in. Hg to 406 psig).</p>	 <p style="text-align: right;">Danfoss 27H451.10</p>	<p>Products</p> <ul style="list-style-type: none"> 1 × ICS 3 Pilots 2 × CVP (HP) 1 × EVM 1 × coil 	
<p>Example no. 3-21</p> <p>Differential pressure regulation combined with electrical wide open and shut off. 0 to 22 bar g (0 to 319 psig).</p>	 <p style="text-align: right;">Danfoss 27H454.10</p>	<p>Products</p> <ul style="list-style-type: none"> 1 × ICS 3 Pilots 1 × CVPP (HP) 2 × EVM 2 × coils 	
<p>Example no. 3-25</p> <p>Crankcase pressure regulation (max. suction pressure regulation) at low pressure drops across the valve. -0.45 to 7 bar g (13.3 in. Hg to 102 psig).</p>	 <p style="text-align: right;">Danfoss 27H455.10</p>	<p>Products</p> <ul style="list-style-type: none"> 1 × ICS 3 Pilots 1 × blanking plug 1 × nipple for external control pressure 1 × CVC 	
<p>Example no. 3-31</p> <p>Electronically controlled media temperature regulation combined with electrical shut off and changeover to constant pressure regulation. -1 to 8 bar g (0 in. Hg to 116 psig).</p>	 <p style="text-align: right;">Danfoss 27H63.10</p>	<p>Products</p> <ul style="list-style-type: none"> 1 × ICS 3 Pilots 1 × CVQ 1 × CVP (LP) 1 × EVM 1 × coil 	



WVFX: Correct condensing and receiver pressure

The pressure controlled water valve WVFX are used for regulating the flow of water in refrigeration plant with water-cooled condensers. The water valve modulates the condensing pressure to maintain it at a constant level during operation. When the refrigeration plant is stopped, the cooling water flow is shut off automatically.

Features

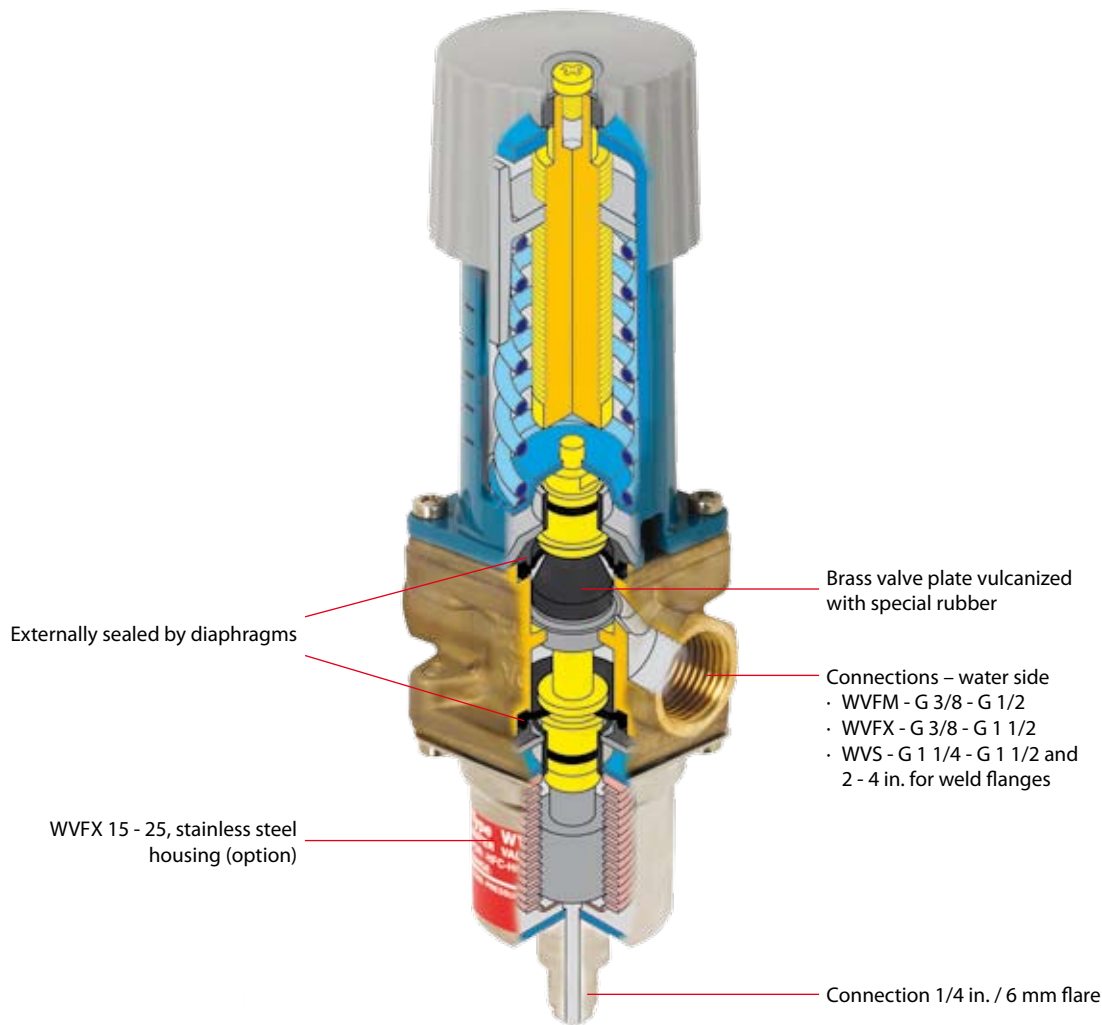

Applications	Advantages	Facts
<ul style="list-style-type: none"> · Traditional refrigeration · Air conditioning units · Other applications with watercooled condenser 	<ul style="list-style-type: none"> · WVFX 15, 20 and 25 can be supplied in stainless steel housing which can be used in connection with sea water cooling of condensers and compressors. · The valves are pressure-relieved in such a way that a variation in the water pressure will not affect their setting. 	<ul style="list-style-type: none"> · Below 20% of max. capacity the WVS will act as an on-off regulator. · WVFX 10 - 40 are direct actuated valves. · WVS 32 - 100 are servo-operated valves.

Technical data and ordering

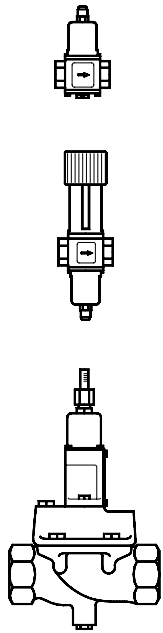

WVFX, complete valves

Type	Connection		Range bar	Code no.
	Water side ISO 228/1	Condenser side		
WVFX 10	G 3/8	1/4 in. / 6 mm flare	3.5 16	003N1100
WVFX 10	G 3/8	1/4 in. / 6 mm flare	4.0 23	003N1105
WVFX 15	G 1/2	1/4 in. / 6 mm flare	3.5 16	003N2100
WVFX 15	G 1/2	1/4 in. / 6 mm flare	4.0 23	003N2105
WVFX 20	G 3/4	1/4 in. / 6 mm flare	3.5 16	003N3100
WVFX 20	G 3/4	1/4 in. / 6 mm flare	4.0 23	003N3105
WVFX 25	G 1	1/4 in. / 6 mm flare	3.5 16	003N4100
WVFX 25	G 1	1/4 in. / 6 mm flare	4.0 23	003N4105
WVFX 32	G 1 1/4	1/4 in. / 6 mm flare	4.0 17	003F1232
WVFX 40	G 1 1/2	1/4 in. / 6 mm flare	4.0 17	003F1240

WVFX with stainless steel housing (W. no. 1.4581)

WVFX 15	G 1/2	1/4 in. / 6 mm flare	3.5 16	003N2101
WVFX 15	G 1/2	1/4 in. / 6 mm flare	4.0 23	003N2104
WVFX 20	G 3/4	1/4 in. / 6 mm flare	3.5 16	003N3101
WVFX 20	G 3/4	1/4 in. / 6 mm flare	4.0 23	003N3104
WVFX 25	G 1	1/4 in. / 6 mm flare	3.5 16	003N4101
WVFX 25	G 1	1/4 in. / 6 mm flare	4.0 23	003N4104

WVS, parts programme

Type	Connection	Code no.			
		Valve body	Pilot unit ³⁾	Flange set ⁴⁾	Servo spring for differential pressure range of 1 10 bar
WVS 32	1 1/4 ¹⁾	016D5032	016D1017		016D1327
WVS 40	1 1/2 ¹⁾	016D5040	016D1017		016D0575
WVS 50	2 weld flange	016D5050 ²⁾	016D1017	027N3050	016D0576
WVS 65	2 1/2 weld flange	016D5065 ²⁾	016D1017	027N3065	016D0577
WVS 80	3 weld flange	016D5080 ²⁾	016D1017	027N3080	016D0578
WVS 100	4 weld flange	016D5100 ²⁾	016D1017	027N3100	016D0579

- 1) ISO 228/1 - G
 2) Code numbers cover valve body, flange gaskets, flange bolts and screws for pilot valve.
 3) Code numbers cover control element and spring housing.
 4) Code numbers cover an inlet and an outlet flange.

Accessories

Description	Code no.
1 m capillary tube 1/4 in. (6 mm) flare coupling nuts at each end	060-0071
Bracket for WVFX 10 25	003N0388

Technical data

Type	Refrigerant	Condenser side			Media	Liquid side		k _v value ¹⁾ m ³ /h
		Control press. adjustable closing press. bar	Max. working pressure PB bar	Max. test pressure p' bar		Max. working pressure PB bar	Max. test pressure p' bar	
WVFX 10 ²⁾	CFC, HCFC, HFC	4.0 23.0	26.4	29.0	Fresh water, neutral brine, sea water ³⁾	16	24	1.4
WVFX 15		3.5 16.0	26.4	29.0		16	24	1.9
WVFX 15 ²⁾		4.0 23.0	26.4	29.0		16	24	1.9
WVFX 20		3.5 16.0	26.4	29.0		16	24	3.4
WVFX 20 ²⁾		4.0 23.0	26.4	29.0		16	24	3.4
WVFX 25		3.5 16.0	26.4	29.0		16	24	5.5
WVFX 25 ²⁾		4.0 23.0	26.4	29.0		16	24	5.5
WVFX 32		4.0 17.0	24.1	26.5		10	10	11.0
WVFX 40		4.0 17.0	24.1	26.5		10	10	11.0
WVS 32		CFC, HCFC, HFC R717 (NH ₃)	2.2 19.0	26.4		29.0	Fresh water, neutral brine	10
WVS 40	2.2 19.0		26.4	29.0	10	16		21.0
WVS 50	2.2 19.0		26.4	29.0	10	16		32.0
WVS 65	2.2 19.0		26.4	29.0	10	16		45.0
WVS 80	2.2 19.0		26.4	29.0	10	16		80.0
WVS 100	2.2 19.0		26.4	29.0	10	16		125.0

- 1) The k_v value is the flow of water in m³/h at a pressure drop across valve of 1 bar, ρ = 1000 kg/m³.
 2) Fully open valve requires 33% higher pressure than a WVFX, range 3.5 16 bar.
 3) WVFX 15, 20 and 25 with stainless steel housing only.



AVTA : Thermostatic regulation of condensing water

Thermostatically operated valves are used for the infinite, proportional regulation of flow quantity, depending on the setting and the sensor temperature.

The valves are self-acting, i.e. they operate without the supply of auxiliary energy such as electricity.

The required temperature is maintained constant with no over consumption of cooling water in cooling systems.

Features

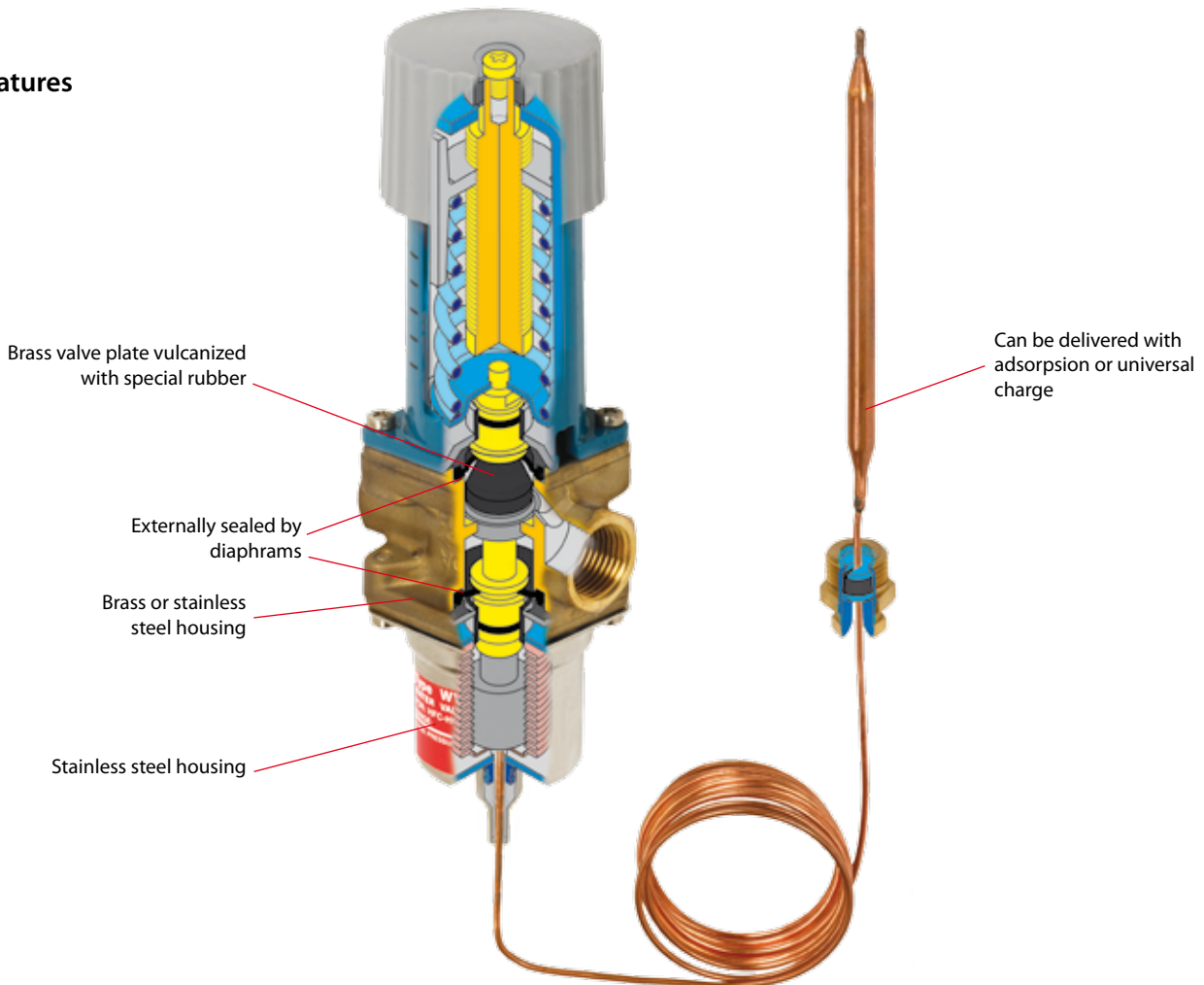

Applications	Advantages	Facts
<ul style="list-style-type: none"> Traditional refrigeration with water cooled condenser 	<ul style="list-style-type: none"> Insensitive to dirt Insensitive to water pressure Needs no power supply - self acting The valve can be placed in any position 	<ul style="list-style-type: none"> Differential pressure: 0 to 10 bar Max. working pressure: 16 bar Max. pressure on sensor: 25 bar Opens on rising sensor temperature The regulation range is defined for the point at which the valve begins to open

Technical data and ordering

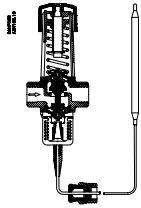

Small sensor dimensions
– Ø 9,5 × 160 mm

AVTA with adsorption charge

Connection ISO 228	Regulating range [°C]	Max.temp. sensor [°C]	k_v value (m ³ /h at $\Delta p = 1$ bar)	Capillary tube length [m]	Type	Code no. ¹⁾
G 3/8	+10 to +80	130	1.4	2.3	AVTA 10	003N1144
G 1/2			1.9		AVTA 15	003N0107
G 3/4			3.4		AVTA 20	003N0108
G 1			5.5		AVTA 25	003N0109

1) Code no. covers complete valve incl. capillary tube gland. Immersion pockets, see "Spare parts and accessories", page 8.

The charge consists of active carbon and CO₂ which is adsorbed on falling sensor temperature and thereby produces pressure changes in the element.

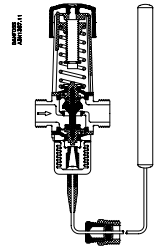

Sensor dimensions
– Ø 18 × 210 mm

AVTA with universal charge

Connection ISO 228	Regulating range [°C]	Max.temp. sensor [°C]	k_v value (m ³ /h at $\Delta p = 1$ bar)	Capillary tube length [m]	Type	Code no. ¹⁾		
G 3/8	+0 to +30	57	1.4	2.0	AVTA 10	003N1132		
G 1/2			1.9		AVTA 15	003N2132		
G 3/4			3.4		AVTA 20	003N3132		
G 1			5.5		AVTA 25	003N4132		
G 3/8	+25 to +65	90	1.4	2.0	AVTA 10	003N1162		
G 1/2			1.9	2.0	AVTA 15	003N2162		
G 1/2			1.9	2.0 (armoured)	AVTA 15	003N0041		
G 3/4			3.4	2.0	AVTA 20	003N3162		
G 3/4			3.4	5.0	AVTA 20	003N3165		
G 3/4			3.4	2.0 (armoured)	AVTA 20	003N0031		
G 1			5.5	2.0	AVTA 25	003N4162		
G 1			5.5	2.0 (armoured)	AVTA 25	003N0032		
G 1			5.5	5.0	AVTA 25	003N4165		
G 3/8			+50 to +90	125	1.4	2.0	AVTA 10	003N1182
G 1/2					1.9	2.0	AVTA 15	003N2182
G 3/4					3.4	2.0	AVTA 20	003N3182
G 1	5.5	2.0			AVTA 25	003N4182		
G 1	5.5	3.0			AVTA 25	003N4183 ²⁾		

1) Code no. covers complete valve incl. capillary tube gland.
2) A Ø 2 mm bypass is drilled in the valve body.

The charge is a mix of liquid and gas where the liquid surface (regulating point) is always inside the sensor. Which charge medium is used depends on the regulation range.

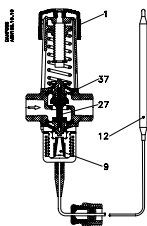

Small sensor dimensions
– Ø 9,5 × 160 mm

AVTA with mass charge

Connection ISO 228	Regulating range [°C]	Max.temp. sensor [°C]	k_v value (m ³ /h at $\Delta p = 1$ bar)	Capillary tube length [m]	Type	Code no. ¹⁾
G 1/2	+0 to +30	57	1.9	2.0	AVTA 15	003N0042
G 3/4			3.4		AVTA 20	003N0043
G 1/2	+25 to +65	90	1.9	2.0	AVTA 10	003N0045
G 1/2			1.9	2.0 (armoured)	AVTA 15	003N0299
G 1/2			1.9	5.0	AVTA 15	003N0034
G 3/4			3.4	2.0	AVTA 20	003N0046
G 1			5.5	2.0	AVTA 25	003N0047

1) Code no. covers complete valve incl. capillary tube gland.

The charge is a mix of liquid and gas. Due to the volumetric conditions the sensor must be installed warmer than the valve, since the liquid surface (regulation point) must be in the sensor.

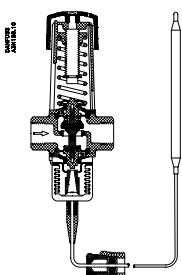

Small sensor dimensions
– Ø 9,5 × 160 mm

AVTA in stainless steel with adsorption charge

Connection ISO 228	Regulating range [°C]	Max.temp. sensor [°C]	k_v value (m ³ /h at $\Delta p = 1$ bar)	Capillary tube length [m]	Type	Code no. ¹⁾
G 1/2	+10 to +80	130	1.9	2.3	AVTA 15	003N2150
G 3/4			3.4		AVTA 20	003N3150
G 1			5.5		AVTA 25	003N4140

1) Code no. covers complete valve incl. capillary tube gland.

The charge consists of active carbon and CO₂ which is adsorbed on falling sensor temperature and thereby produces pressure changes in the element.

GBC: excellent mounting and service

GBC ball valves are manually operated shut-off valves suitable for bi-directional flow. Ball valves are used in liquid, suction and hot gas lines in refrigeration, freezing and air conditioning systems. The GBC bi-directional ball valves can be delivered with or without external access port. The valves have one-piece wire seal cap to prevent unintentional cap removal or tampering between services.

Features

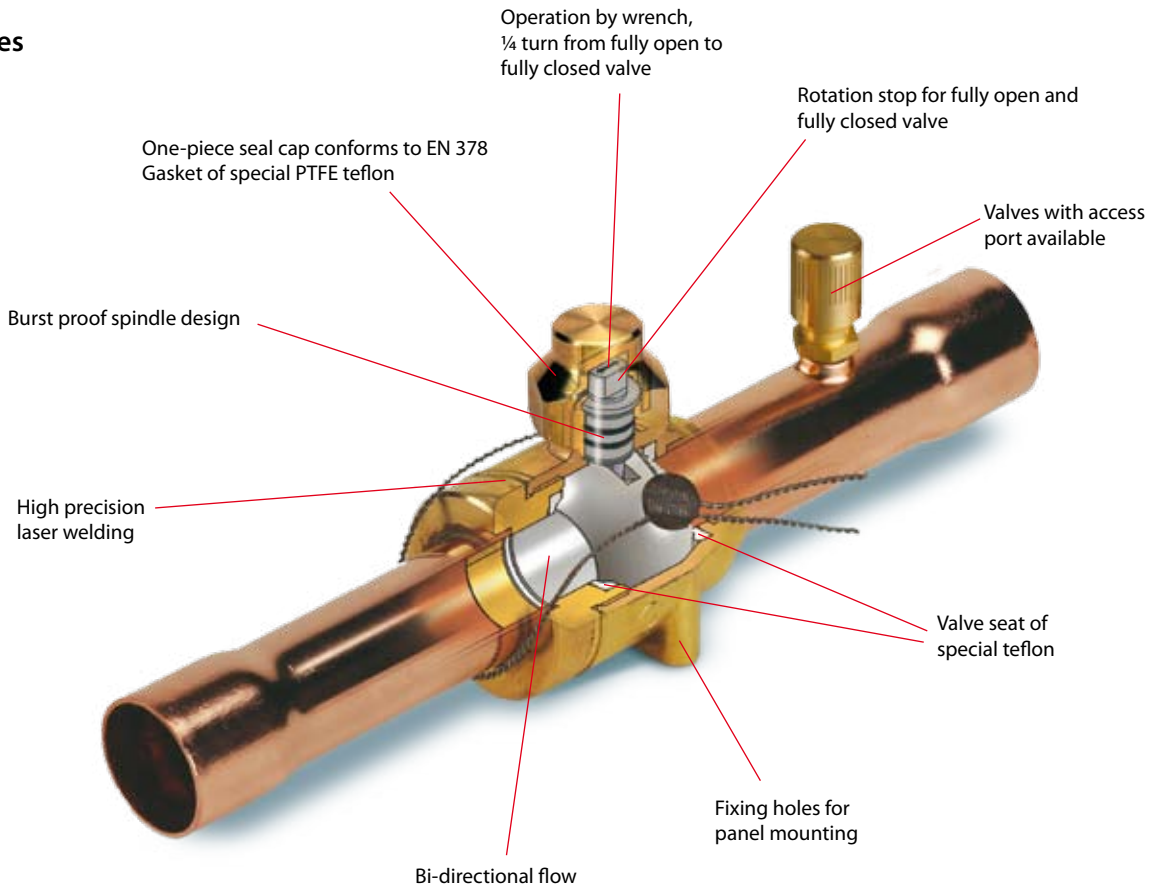

Applications	Advantages	Facts
<ul style="list-style-type: none"> GBC valves are used in liquid, suction and hot gas lines in all refrigeration and air-conditioning systems with fluorinated refrigerants. 	<ul style="list-style-type: none"> Full flow with minimum pressure drop. Bi-directional flow, i.e. valve orientation is unimportant. Slimline design ensures easy operational handling. Burst proof spindle design prevents liquid from being trapped internally. Valve seat of special teflon to secure maximum tightness and a long life-time. The available access port saves money if service of the system is necessary. 	<ul style="list-style-type: none"> GBC can be used for all fluorinated refrigerants (CFC, HCFC and HFC). Temperature range: -40 to +150°C Max. working pressure (PS/MWP) 45 bar (650 psig). Test pressure: 65 bar (940 psig). Approvals: UL, CSA and CE.

Technical data and ordering

Standard valve

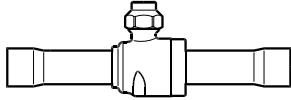

Standard GBC valve

Type	Solder ODF connection		Solder ODF connection		k _v value ¹⁾
	in.	Code no. ²⁾	mm	Code no. ²⁾	
GBC 6s	1/4	009G7020	6	009G7030	2.0
GBC 10s	3/8	009G7021	10	009G7031	5.7
GBC 12s	1/2	009G7022	12	009G7032	10.6
GBC 16s	5/8	009G7023	16	009G7023	14.1
GBC 18s	3/4	009G7024	18	009G7035	20.4
GBC 22s	7/8	009G7025	22	009G7025	28.2
GBC 28s	1 1/8	009G7026	28	009G7033	52.0
GBC 35s	1 3/8	009G7027	35	009G7027	80.9
GBC 42s	1 5/8	009G7028	42	009G7034	121
GBC 54s	2 1/8	009G7029	54	009G7029	225
GBC 67s	2 5/8	009G7036			246
GBC 79s	3 1/8	009G7037			223

Valve with access port



GBC valve with access port

Type	Solder ODF connection		Solder ODF connection		k _v value ¹⁾
	in.	Code no. ²⁾	mm	Code no. ²⁾	
GBC 6s	1/4	009G7050	6	009G7060	2.0
GBC 10s	3/8	009G7051	10	009G7061	5.7
GBC 12s	1/2	009G7052	12	009G7062	10.6
GBC 16s	5/8	009G7053	16	009G7053	14.1
GBC 18s	3/4	009G7054	18	009G7065	20.4
GBC 22s	7/8	009G7055	22	009G7055	28.2
GBC 28s	1 1/8	009G7056	28	009G7063	52.0
GBC 35s	1 3/8	009G7057	35	009G7057	80.9
GBC 42s	1 5/8	009G7058	42	009G7064	121
GBC 54s	2 1/8	009G7059	54	009G7059	225
GBC 67s	2 5/8	009G7066			246
GBC 79s	3 1/8	009G7067			223

¹⁾ CFD calculated values (Computational Fluid Dynamics)

²⁾ Code numbers in bold are normally on stock and a shorter delivery time can, therefore, be expected.





NRV and NRVH: correct flow direction - flexible to use

NRV and NRVH check valves can be used in liquid, suction and hot gas lines in refrigeration and air conditioning plants with fluorinated refrigerants. The valves ensure the correct flow direction and prevent back-condensation from a warm part of the system to the cold evaporator. A built-in damping piston makes the valves suitable for installation in lines where pulsation can occur, e.g. in the discharge line from the compressor.

Features

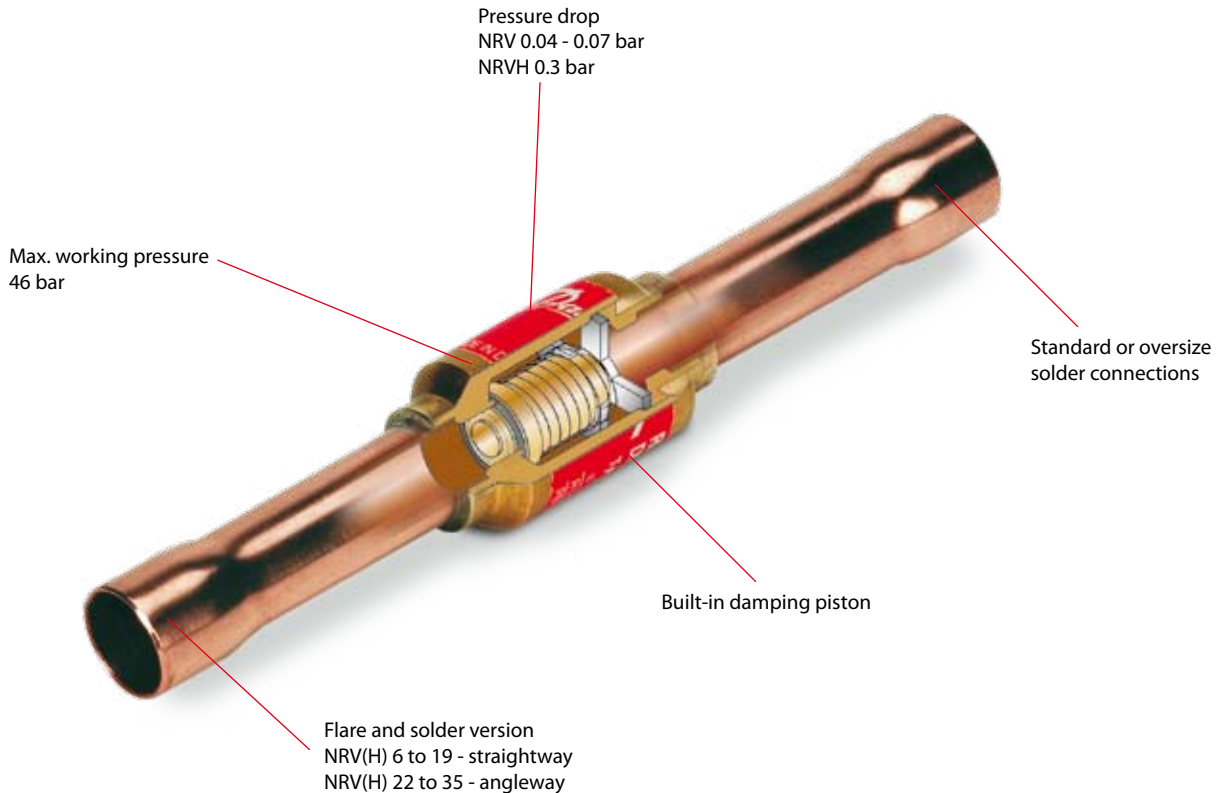

Applications	Advantages	Facts
<ul style="list-style-type: none"> Traditional refrigeration Heat pump systems Air conditioning units Liquid coolers Transport refrigeration 	<ul style="list-style-type: none"> For all fluorinated refrigerants Resonance problems can be avoided at partial load in the refrigeration plant. Oversize connections provide flexibility in use. Prevents back-condensation from warm to cold system part. Ensures correct flow direction. 	<ul style="list-style-type: none"> In refrigeration plants with compressors connected in parallel, it is advantageous to use NRVH, since the spring is stronger than in NRV. Both straightway and angleway versions. Max. working pressure PS/MWP = 46 bar Max. test pressure p' = 60 bar Temperature of the medium -50 140°C

Technical data and ordering

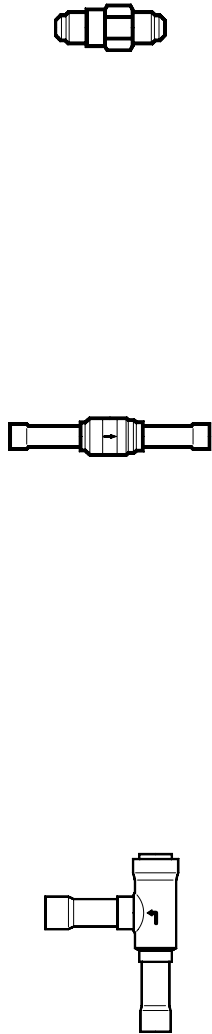

Type	Version		Connection				Pressure drop across valve Δp bar ²⁾	k_v -value ³⁾ m ³ /h	Max. working pressure				
			in.		mm								
			Size	Code no. ¹⁾	Size	Code no. ¹⁾							
NRV6	Flare		¼	020-1040	6	020-1040	0.07	0.56	46 bar				
NRV 10			¾	020-1041	10	020-1041		1.43					
NRV 12			½	020-1042	12	020-1042		2.05					
NRV 16			⅝	020-1043	16	020-1043	0.05	3.60					
NRV 19			¾	020-1044	19	020-1044		5.50					
NRV 6s			Straight-way		¼	020-1010	6	020-1014		0.07	0.56		
NRV 6s ⁴⁾	¾	020-1057			10	020-1050							
NRVH 6s ⁴⁾	¾	020-1069			10	020-1062	0.30						
NRV 10s	¾	020-1011			10	020-1015	0.07	1.43					
NRVH 10s	¾	020-1046			10	020-1036	0.30						
NRV 10s ⁴⁾	½	020-1058			12	020-1051	0.07						
NRVH 10s ⁴⁾	½	020-1070			12	020-1063	0.30	2.05					
NRV 12s	½	020-1012			12	020-1016	0.05						
NRVH 12s	½	020-1039			12	020-1037	0.30						
NRV 12s ⁴⁾	Solder ODF				⅝	020-1052	16	020-1052		0.05	3.60		
NRVH 12s ⁴⁾					⅝	020-1064	16	020-1064		0.30			
NRV 16s					⅝	020-1018	16	020-1018		0.05			
NRVH 16s					⅝	020-1038	16	020-1038		0.30	5.50		
NRV 16s ⁴⁾					-	-	18	020-1053		0.05			
NRVH 16s ⁴⁾					-	-	18	020-1065		0.30			
NRV 16s ⁴⁾					Angle-way		¾	020-1059		19	020-1059	0.05	8.50
NRVH 16s ⁴⁾							¾	020-1071		19	020-1071	0.30	
NRV 19s							-	-		18	020-1017	0.05	
NRVH 19s							-	-		18	020-1008	0.30	19.00
NRV 19s							¾	020-1019		19	020-1019	0.05	
NRVH 19s							¾	020-1023		19	020-1023	0.30	
NRV 19s ⁴⁾					⅞	020-1054	22	020-1054		0.05	29.00		
NRVH 19s ⁴⁾					⅞	020-1066	22	020-1066		0.30			
NRV 22s					⅞	020-1020	22	020-1020		0.04			
NRVH 22s			⅞	020-1032	22	020-1032	0.30	19.00					
NRV 22s ⁴⁾			1½	020-1060	28	020-1055	0.04						
NRVH 22s ⁴⁾			1½	020-1072	28	020-1067	0.30						
NRV 28s	1½	020-1021	28	020-1025	0.04	29.00							
NRVH 28s	1½	020-1029	28	020-1033	0.30								
NRV 28s ⁴⁾	1¾	020-1056	35	020-1056	0.04								
NRVH 28s ⁴⁾	1¾	020-1068	35	020-1068	0.30	29.00							
NRV 35s	1¾	020-1026	35	020-1026	0.04								
NRVH 35s	1¾	020-1034	35	020-1034	0.30								
NRV 35s ⁴⁾			1½	020-1061	42	020-1027	0.04	29.00					
NRVH 35s ⁴⁾			1½	020-1073	42	020-1035	0.30						

¹⁾ Code numbers in bold are normally on stock and a shorter delivery time can, therefore, be expected.
²⁾ Δp = the minimum pressure at which the valve is completely open.
The NRVH with a stronger spring is used in the discharge line from compressors connected in parallel.
³⁾ The k_v value is the flow of water in m³/h at a pressure drop across valve of 1 bar, $\rho = 1000 \text{ kg/m}^3$.
⁴⁾ Oversize connections.



OUB: The easy way for oil return

The oil separator type OUB is for use in all refrigeration plant where the compressor lubricating oil must be returned direct to the compressor oil sump under all operating conditions. In this way lubricating oil from the compressor is prevented from circulating with the refrigerant in the refrigeration system itself.

Features

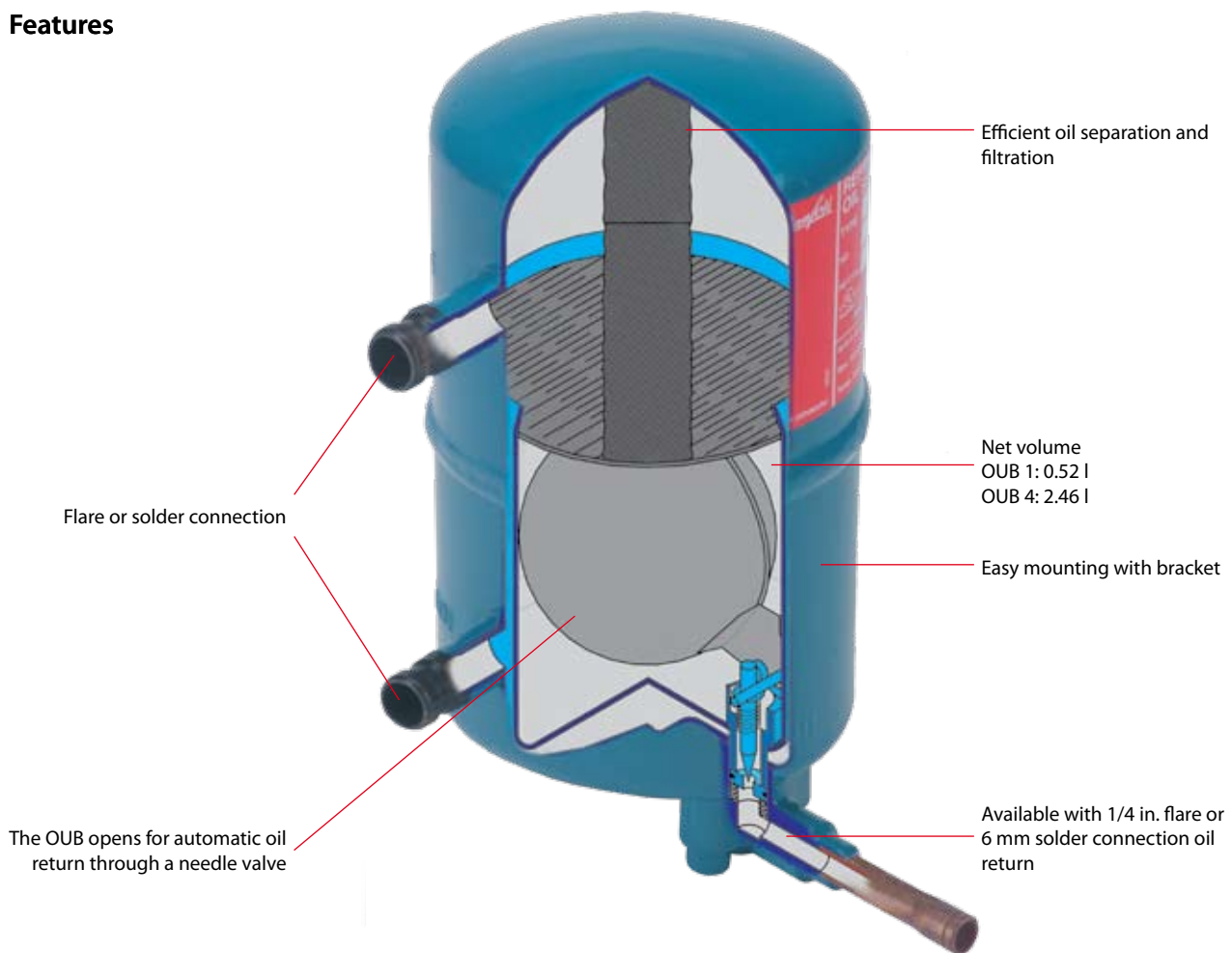

Applications	Advantages	Facts
<ul style="list-style-type: none"> Traditional refrigeration Air conditioning units 	<ul style="list-style-type: none"> High efficiency Due to the interaction of reduced flow and a change of flow direction for oil concentration. The collection of the separated oil at high temperature and the automatic return of the oil to the crankcase. High efficiency Protects against liquid hammer in compressor Better utilisation of condenser and evaporator capacity (no oil-gas collection). 	<ul style="list-style-type: none"> Ensures oil return to compressor oil sump. Prevents compressor breakdown caused by lack of lubrication. Increases compressor operating life. Pulsation and noise damping on high-pressure side of system Max. working pressure PS = 28 bar Refrigerants CFC, HCFC, HFC

Technical data and ordering

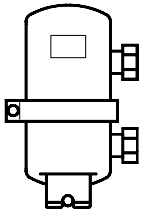

OUB 1 / OUB 4

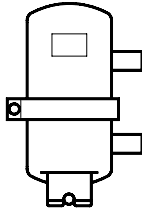

OUB 1s

Type	Connection			Rated plant capacity kW					Code no. for OUB + unions (straightway)
	in.	mm	Version	R22	R134a	R404A	R507	R407C	
OUB 1	3/8	10	Flare	3.1	2.5	3.5	3.5	4.4	040B0010 + 2 × 040B0132
	3/8		Solder						040B0010 + 2 × 040B0140
		10	Solder						040B0010 + 2 × 040B0138
	1/2	12	Flare						040B0010 + 2 × 040B0134
	1/2		Solder						040B0010 + 2 × 040B0142
		12	Solder						040B0010 + 2 × 040B0139
	5/8	16	Flare						040B0010 + 2 × 040B0136
	5/8	16	Solder						040B0010 + 2 × 040B0144
Without connection unions									040B0010
OUB 1s ¹⁾		10	Solder	3.1	2.5	3.5	3.5	4.4	040B0023
OUB 1s ²⁾		10	Solder						040B0029
OUB 4	5/8	16	Flare	11.6	9.6	12.8	12.8	16.0	040B0040 + 2 × 040B0256
	5/8	16	Solder						040B0040 + 2 × 040B0266
	3/4	18	Flare						040B0040 + 2 × 040B0258
	3/4		Solder						040B0040 + 2 × 040B0268
	7/8		Solder						040B0040 + 2 × 040B0270
		22	Solder						040B0040 + 2 × 040B0264
	1	25	Flare						040B0040 + 2 × 040B0260
	1		Solder						040B0040 + 2 × 040B0272
	1 1/8		Solder						040B0040 + 2 × 040B0274
		28	Solder						040B0040 + 2 × 040B0265
	Without connection unions								

- 1) 1/4 in. flare connection to oil return line.
 2) 6 mm ODF solder connection to oil return line.

HE : utilization of cooling effect

Heat exchanger type HE is used primarily for heat transfer between the liquid and suction lines of the refrigeration plant.

The purpose is to utilize the cooling effect which without a heat exchanger is otherwise lost to the ambient air via uninsulated suction lines.

In the heat exchanger, this effect is used to subcool the refrigerant liquid.

Features

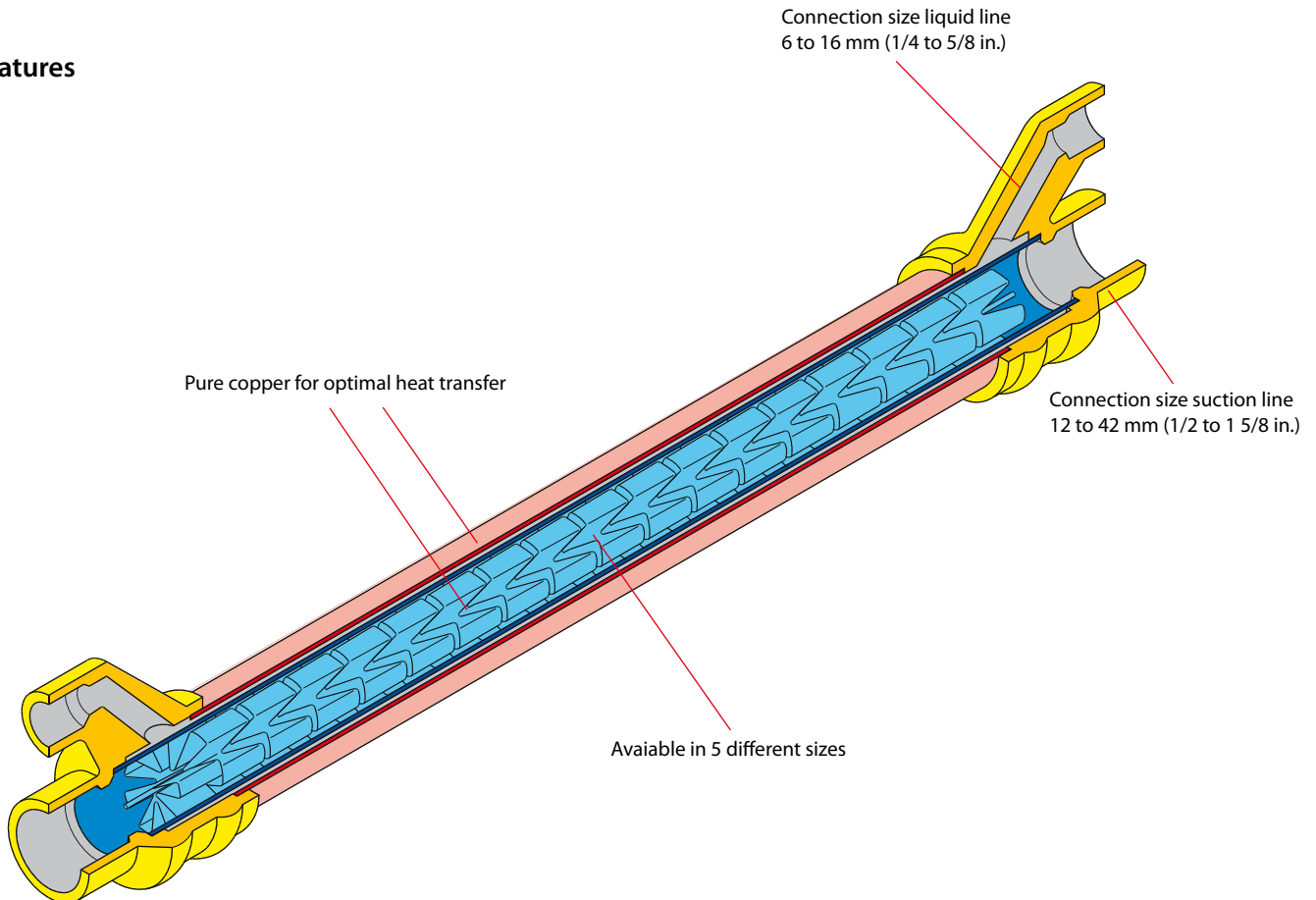

Applications	Advantages	Facts
<ul style="list-style-type: none"> Traditional refrigeration Air conditioning units 	<ul style="list-style-type: none"> The design is such that normal suction gas velocities are achieved, with a subsequent small pressure drop. Thus the heat exchanger capacity will match plant capacity. At the same time, oil return to the compressor is ensured. An HE used as an auxiliary condenser must always be selected according to the connection dimensions. 	<ul style="list-style-type: none"> For use with CFC, HCFC and HFC refrigerants Max. working pressure HE 0.5, 1.0, 1.5, 4.0: PS = 28 bar HE 8.0: PS = 21.5 bar

Technical data and ordering

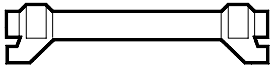

Type	Solder connection ODF				Code no.
	Liquid line		Suction line		
	in.	mm	in.	mm	
HE 0.5		6		12	015D0001
	1/4		1/2		015D0002
HE 1.0		10		16	015D0003
	3/8		5/8		015D0004
HE 1.5		12		18	015D0005
	1/2		3/4		015D0006
HE 4.0		12		28	015D0007
	1/2		1 1/8		015D0008
HE 8.0		16		42	015D0009
	5/8		1 5/8		015D0010

Selection

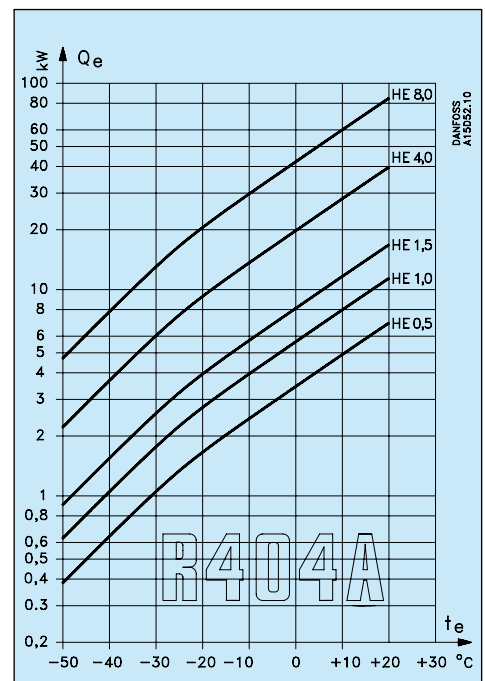
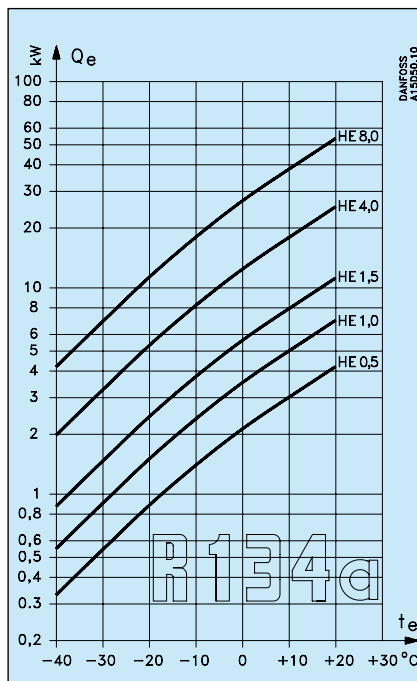
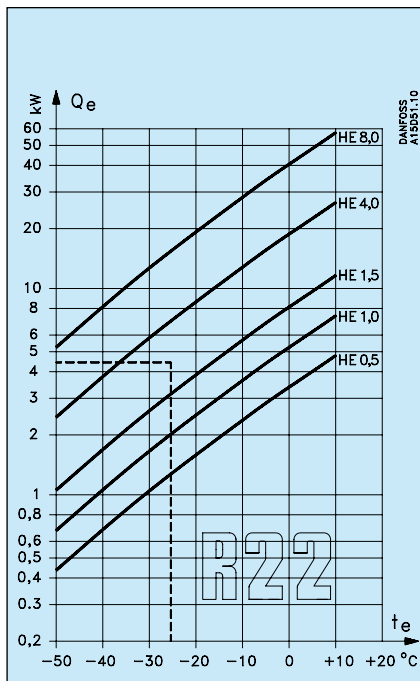

The curve for R22 shows that an HE 4.0 is suitable. The curve for HE 4.0 lies immediately above the intersection of the lines through

$$Q_e = 4.5 \text{ kW and } t_e = -25^\circ\text{C.}$$

The heat flow Q during heat exchange is calculated from the formula:

$$Q = k \times A \times \Delta t_m$$

Q heat flow in W

k heat transfer coefficient in $W/m^2 \text{ } ^\circ\text{C}$

A transfer area of the heat exchanger in m^2

Δt_m the average temperature difference in $^\circ\text{C}$, calculated from the formula:

$$\Delta t_m = \frac{\Delta t_{\max} - t_{\min.}}{\ln \frac{\Delta t_{\max.}}{\Delta t_{\min.}}}$$

$k \times A$ values

Determined by experiment (see table).

Type	$K \times A$
	¹⁾ Dry suction gas / refrigerant liquid (normal use in refrigeration plant with fluorinated refrigerants) $W / ^\circ\text{C}$
HE 0.5	2.3
HE 1.0	3.1
HE 1.5	4.9
HE 4.0	11.0
HE 8.0	23.0

¹⁾ These figures apply to dry gas only. Even if a thermostatic expansion valve is used, the suction gas will carry very small liquid drops into the suction line. The fins of the HE catch these drops which then evaporate. This may result in a smaller superheat than the theoretically calculated value.

Precise heat exchanger sizing can be obtained from the curves which show plant capacity Q_e for R22, R134a and R404A depending on evaporating temperature t_e .

Example

Plant capacity $Q_e = 4.5 \text{ kW}$

Refrigerant = R22

Evaporating temperature $t_e = -25^\circ\text{C}$



SGN/H, SGR, SGRN/H: secure optimal protection

Sight glasses are mostly installed in the liquid line between the filter drier and the expansion valve to monitor the condition of the refrigerant. The SGR is mainly used to indicate the condition of the refrigerant as well as the liquid level in the receiver or the oil level in the compressor and has no moisture indicator. The SGN/H and SGRN/H are equipped with sensitive indicators that reflect a colour, depending on the moisture content in the refrigerant.



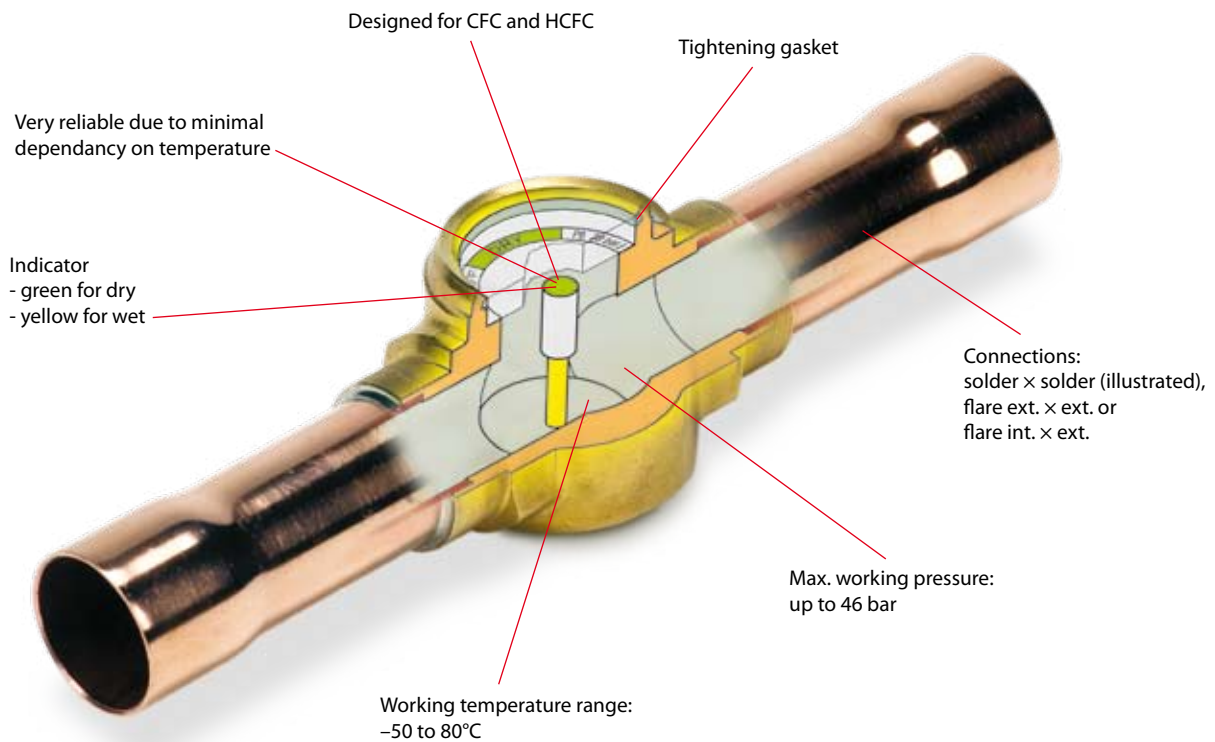







Features



Applications	Advantages	Facts
<ul style="list-style-type: none"> Traditional refrigeration Heat pump systems Air conditioning units Liquid coolers Transport refrigeration 	<ul style="list-style-type: none"> Best visual indication of moisture (minimal dependence on temperature). The flare ext. x int. version can be screwed together with filter drier (reduction of assembly costs). Flare connections are 4-sided for quick installation. Extended solder connections. Glass diameter permits high working pressures. 	<ul style="list-style-type: none"> Designed for HFC refrigerants. Flare-/solder connection or socket type. Wide range with sizes from 6 to 22 mm. Max. working pressure: up to 46 bar. Working temperature: -50 to 80°C. Approvals: PED, UL, GOST.

Technical data and ordering

	Moisture content ppm = parts per million					
	Green - dry	Intermed. color	Yellow - wet	Green - dry	Intermed. color	Yellow - wet
SGN and SGRN	Liquid temperature 25°C			Liquid temperature 43°C		
R22	< 30	30 - 120	>120	< 50	50 - 200	>200
R134a	< 30	30 - 100	>100	< 45	45 - 170	>170
R404A	< 20	20 - 70	> 70	< 25	25 - 100	>100
R407C	< 30	30 - 140	>140	< 60	60 - 225	>225
R507	< 15	15 - 60	> 60	< 30	30 - 110	>110
SGH and SGRH	Liquid temperature 25°C			Liquid temperature 43°C		
R410A	< 20	20 - 165	>165	< 40	40 - 350	>350

Type	Version	Connection		Code no. ¹⁾	MWP	
		in.	mm			
 SGN 6 SGN 10 SGN 12 SGN 16 SGN 19	Flare, ext. x ext.	1/4 x 1/4	6 x 6	014-0161	35	
		3/8 x 3/8	10 x 10	014-0162		
		1/2 x 1/2	12 x 12	014-0163		
		5/8 x 5/8	16 x 16	014-0165		
		3/4 x 3/4	19 x 19	014-0166		
 SGN 6 SGN 10 SGN 12 SGN 16 SGN 19	Flare, int. x ext. ²⁾	1/4 x 1/4	6 x 6	014-0171	35	
		3/8 x 3/8	10 x 10	014-0172		
		1/2 x 1/2	12 x 12	014-0173		
		5/8 x 5/8	16 x 16	014-0174		
		3/4 x 3/4	19 x 19	014-0175		
 SGN 6s SGN 6s SGN 10s SGN 10s SGN 12s SGN 12s SGN 16s SGN 18s SGN 19s SGN 22s SGN 22s	Solder, ODF x ODF	1/4 x 1/4	6 x 6	014-0181	35	
		3/8 x 3/8	10 x 10	014-0182		
		1/2 x 1/2	12 x 12	014-0192		
		5/8 x 5/8	16 x 16	014-0183		
		3/4 x 3/4	18 x 18	014-0193		
		7/8 x 7/8	19 x 19	014-0184		
		1 1/8 x 1 1/8	22 x 22	014-0185		
				014-0186		
				014-0187		
 SGN 6s SGN 10s SGN 12s SGN 16s SGN 22s	Solder, ODF x ODM ²⁾	1/4 x 1/4		014-0201	35	
		3/8 x 3/8				014-0202
		1/2 x 1/2				014-0203
		5/8 x 5/8	16 x 16			014-0204
		7/8 x 7/8	22 x 22			014-0206
 SGH 6	Flare, ext. x ext.	1/4 x 1/4		014-1660	46	
 SGH 6s SGH 10s SGH 12s SGH 16s SGH 22s SGH 22s	Solder, ODF x ODF	1/4 x 1/4		014-1090	46	
		3/8 x 3/8				014-1092
		1/2 x 1/2				014-1091
		5/8 x 5/8				014-1094
		7/8 x 7/8				014-1096
		1 1/8 x 1 1/8				014-1098
 SGR	Pipe thread NPT NPT	G 3/4 A ³⁾		014-0004	35	
		3/4 NPT		014-0005		
		1/2 NPT		014-0002		
 SGRN 1/2 SGRN for saddle	NPT M	1/2 NPT		014-0006	35	
		M	M24 x 1	014-1155		
 Sight glass saddle for SGRN	Tube fitting (M24 x 1)	7/8		014-1059	-	
		1 1/8				014-1056
		1 3/8				014-1057
		1 5/8				014-1058
		2 1/8				014-1067
		3 1/8				014-1068
 SGRH for saddle	M		M20 x 1	014-1601	46	
 Sight glass saddle for SGRH	Tube fitting (M20 x 1/2)	3 1/8		014-1072	-	

¹⁾ Code numbers in bold are normally on stock and a shorter delivery time can, therefore, be expected.

²⁾ Can be mounted directly into the filter drier.

³⁾ ISO 228/1.



DML: Excellent protection of your refrigeration system

The DML liquid line filter driers protect refrigeration and air conditioning systems from moisture, acids and solid particles. The 100% solid molecular sieve core, assures a high drying capacity and avoids acid formation in the system.

Features

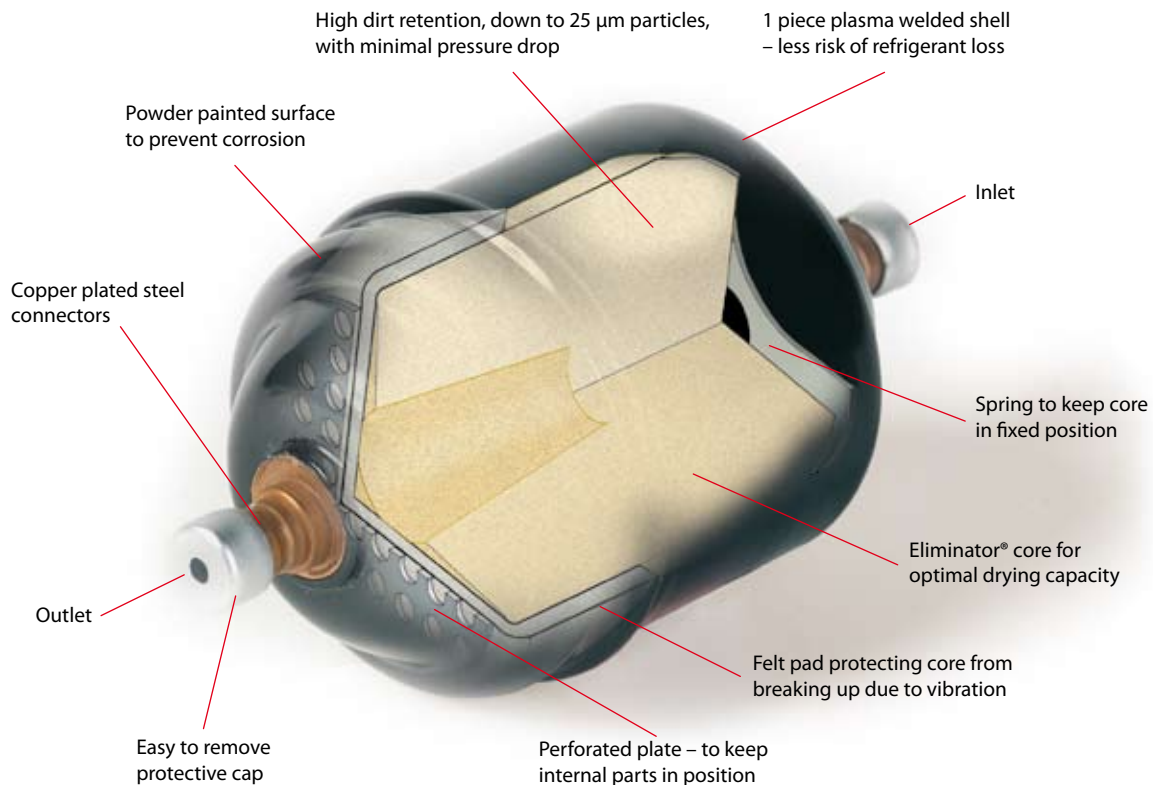

Applications	Advantages	Facts
<ul style="list-style-type: none"> Traditional refrigeration Air conditioning units Transport refrigeration 	<ul style="list-style-type: none"> High drying capacity avoiding the risk of acid formation in the refrigeration system. Driers with flare connections have hard plastic screw type end caps for greater protection and easy removal. Aluminium caps on driers with solder connections. Wide range with sizes from 3 to 75 cubic inches. 	<ul style="list-style-type: none"> 100% 3Å molecular sieve core. Optimized for HFC refrigerants (R134a, R404A, R410A, etc.) with POE and PAG oils. Compatible with R22. MWP (PS): up to 42 bar (610 psi). HCFC & HFC refrigerants. Available with flare- or solder connectors (copper-plated steel). Wide range with sizes from 3 to 75 cubic inches. UL and PED approvals – label indicating internal free volume. Can be installed in any position provided "the arrow" is in the direction of flow.

Technical data and ordering

Filter drier

Type	Connection		Solid core		Drying capacity [kg refrigerant] ¹⁾						Liquid capacity in kW ²⁾			Solder		Flare
			Surface [cm ³]	Volume [cm ³]	R134a		R404A R507		R22 R407C R410A		R134a	R404A R507	R22 R407C R410A	Code no. ³⁾	Code no. ³⁾	Code no. ³⁾
	24°C	52°C			24°C	52°C	24°C	52°C	in.	mm						
DML 032 DML 033	1/4 3/8	6 10	65	41	5.5	5	7.5	4.5	4.5	4	7 17	5 13	7 19	023Z4552⁴⁾ 023Z4555	023Z4551⁴⁾ 023Z4554	023Z5035⁴⁾ 023Z5036 ⁴⁾
DML 052 DML 053	1/4 3/8	6 10	75	65	8.5	8	13	7.5	8	7	7 18	5 14	8 19	023Z4559 023Z4562	023Z4558 023Z4561	023Z5037 023Z5038
DML 082 DML 083 DML 084 DML 085	1/4 3/8 1/2 5/8	6 10 12 16	110	100	12.5	12	20	11.5	12.5	11	7 19 26 42	5 14 20 31	8 21 29 46	023Z4567 023Z4570 023Z4572 023Z4573	023Z4566 023Z4569 023Z4571 023Z4573	023Z5039 023Z5040 023Z5041 023Z5073
DML 162 DML 163 DML 164 DML 165 DML 166	1/4 3/8 1/2 5/8 3/4	6 10 12 16 19	175	225	27	25.5	43.5	24	27	23	7 22 30 43 44	5 16 22 30 31	8 24 33 47 48	023Z4575 023Z4578 023Z4580 023Z4581 023Z4582	023Z4574 023Z4577 023Z4579 023Z4581 023Z4582	023Z5042 023Z5043 023Z5044 023Z5045 023Z5046
DML 303 DML 304 DML 305 DML 306 DML 307	3/8 1/2 5/8 3/4 7/8	10 12 16 19 22	330	480	57	54	92.5	51	57	48.5	21 31 45 62 62	15 22 33 45 45	23 34 49 68 68	023Z4585 023Z4587 023Z4588 023Z4589 023Z4590	023Z4584 023Z4586 023Z4588 023Z4589 023Z4590	023Z0049 023Z0050 023Z0051 023Z0193
DML 414 DML 415 DML 417	1/2 5/8 7/8	12 16 22	400	650	80	75	130	70	80	74	32 53 91	23 37 65	35 58 100	023Z4594 023Z4595 023Z4696	023Z4593 023Z4595 023Z4596	023Z0109 023Z0110
DML 606 DML 607 DML 609	3/4 7/8 1 1/8	19 22 28	660	960	113	107	185	101	114	97	44 75 87	32 54 64	48 82 95	023Z4601 023Z4602 023Z4603	023Z4601 023Z4602 023Z4603	
DML 757 DML 759	7/8 1 1/8	22 28	800	1300	160	150	260	140	160	148	82 94	60 68	90 102	023Z4605 023Z4607	023Z4605 023Z4606	

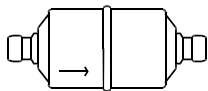

Solder version

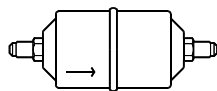

Flare version

- ¹⁾ Drying capacity is based on following moisture content test standards before and after drying:
R134a: From 1050 ppm W to 75 ppm W. If drying to 50 ppm W is required, reduce stated capacities by 15%.
R404A, R507: From 1020 ppm W to 30 ppm W.
R407C: From 1020 ppm W to 30 ppm W.
R410A: From 1050 ppm W to 60 ppm W.
R22: From 1050 ppm W to 60 ppm W in accordance with ARI 710-86.
²⁾ Given in accordance with ARI 710-86 for $t_c = -15^\circ\text{C}$ (5°F), $t_c = 30^\circ\text{C}$ (85°F) and $\Delta p = 0.07$ bar (1 psig).
³⁾ Code numbers in bold are normally on stock and a shorter delivery time can therefore be expected.
⁴⁾ Wire mesh in filter drier outlet.

Flare / solder adapter

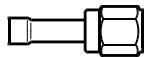

Type	Connection flare x solder in.	Code no. ³⁾ for 1 pc	Code no. ³⁾ for 2 pcs.	Type	Connection flare x solder mm	Code no. ³⁾ for 1 pc	Code no. ³⁾ for 2 pcs.
FSA 22	1/4 x 1/4	023U8012	023U8002	FSA 26m	1/4 x 6	023U8011	023U8001
FSA 32	3/8 x 1/4	023U8022	-	FSA 36m	3/8 x 6	023U8021	-
FSA 33	3/8 x 3/8	023U8014	023U8004	FSA 310m	3/8 x 10	023U8013	023U8003
FSA 44	1/2 x 1/2	023U8016	023U8006	FSA 412m	1/2 x 12	023U8015	023U8005
FSA 516m	5/8 x 5/8	023U8017	023U8007	FSA 516m	5/8 x 16	023U8017	023U8007
FSA 66	3/4 x 3/4	023U8020	023U8010	FSA 618m	3/4 x 18	023U8019	023U8009

Accessories



Copper seal	Size	Qty.	Code no. ³⁾	Copper seal	Size	Qty.	Code no. ³⁾
B2 - 4 spec.	1/4 in./6 mm	300	011L4025	B2 -10	5/8 in./16 mm	100	011L4019
B2 - 6	3/8 in./10 mm	300	011L4017	B2 -12	3/4 in./18 mm	50	011L4020
B2 - 8	1/2 in./12 mm	200	011L4018				



DCR: compact design for easy installation and service

DCR filter driers protect refrigeration and air conditioning systems from moisture, acids and solid particles. They utilise (a) replaceable solid core(s) and are suitable for liquid and suction line installation in both single and multi-compressor configurations. The solid core assures a high drying capacity and avoids acid formation in the system.

Features

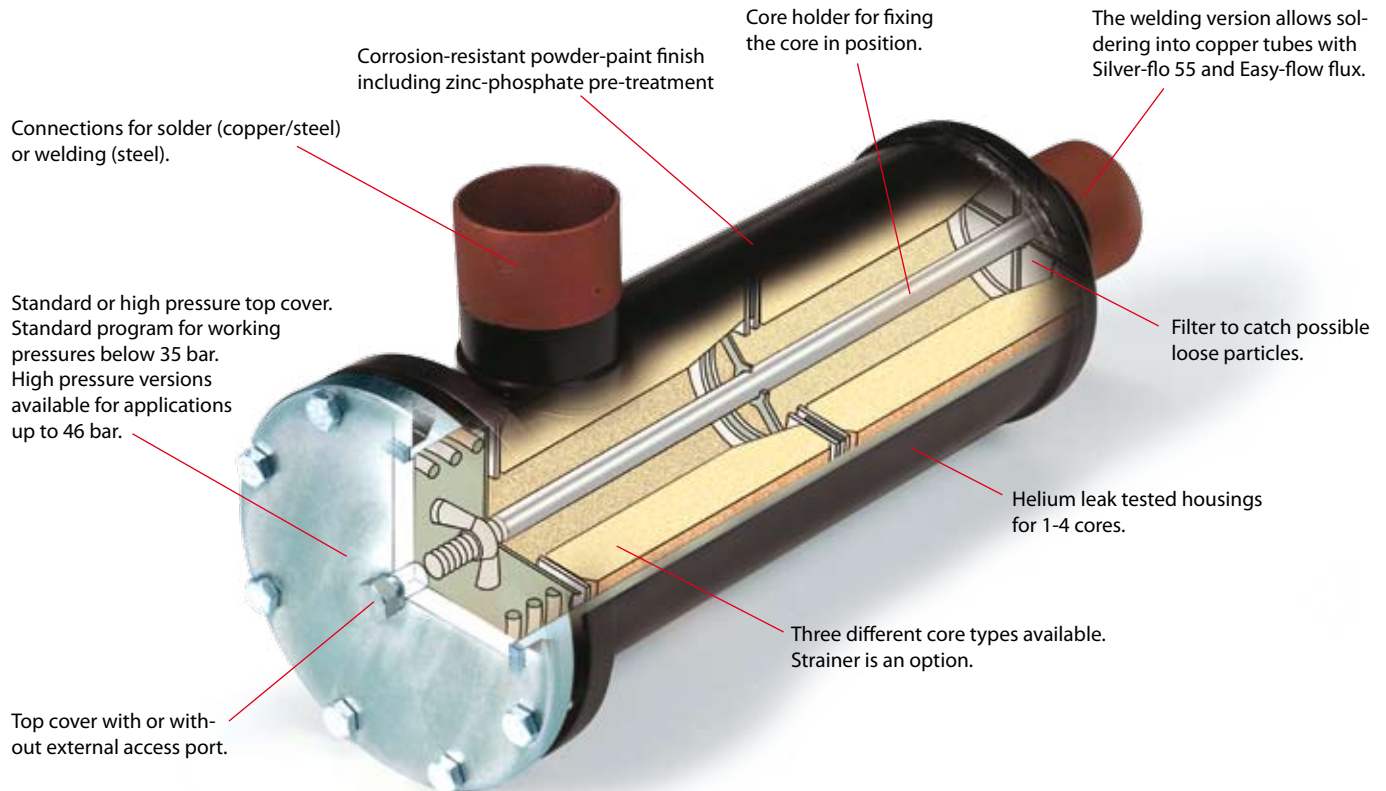

Applications	Advantages	Facts
<ul style="list-style-type: none"> Commercial plants with fluorinated refrigerants or CO₂. Industrial plants with fluorinated refrigerants or CO₂. 	<ul style="list-style-type: none"> Highly efficient dirt retaining capabilities on both the suction and the liquid line. Can be used in all environments, including marine applications. The new core holder requires minimum free space to remove the core for replacement. One of the 8 holes for fixing the screws in the cover has a split screw hole to keep the cover in place (very easy to place the cover back in position and fix the screws). Can be installed in any position. 	<ul style="list-style-type: none"> 48 - DM core for liquid line application (100% molecular sieve for HFC). Provides high moisture adsorption at low and high condensing temperatures. Effective protection against impurities. 48 - DC core for liquid line application (80% molecular sieve and 20% activated alumina for CFC and HCFC). Effectively adsorbs moisture and acid in the system. 48 - DA core for suction line after a compressor burn-out (30% molecular sieve and 70% activated alumina for CFC/HCFC/HFC). 48 - F strainer for suction line.

Capacities

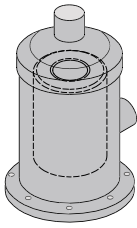

48-DM

Type	Number of cores	Drying capacity [kg refrigerant] ¹⁾						Liquid capacity [kW] ²⁾		
		R134a		R404A/R507		R407C/R410A		R134a	R404A/R507	R407C/R410A
		24°C	52°C	24°C	52°C	24°C	52°C			
DCR 0485	1							79	57	88
DCR 0487								139	99	153
DCR 0489								186	133	206
DCR 04811		82.5	78.5	135.0	74.0	83.0	71.0	227	162	259
DCR 04813								227	162	259
DCR 04817								227	162	259
DCR 04821							227	162	259	
DCR 0967	2							140	100	155
DCR 0969								217	155	240
DCR 09611		165.0	157.0	270.0	148.0	166.0	142.0	295	211	326
DCR 09613								358	256	396
DCR 09617							358	256	396	
DCR 1449	3							226	162	250
DCR 14411								356	255	394
DCR 14413		247.5	235.5	405.0	222.0	249.0	213.0	356	255	394
DCR 14417								356	255	394
DCR 19211	4							372	266	411
DCR 19213		330.0	314.0	540.0	296.0	332.0	284.0	460	329	509
DCR 19217								460	329	509

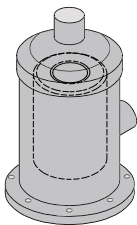

48-DC

Type	Number of cores	Drying capacity [kg refrigerant] ¹⁾								Liquid capacity [kW] ²⁾			
		R22		R134a		R404A/R507		R407C/R410A		R22	R134a	R404A/R507	R407C/R410A
		24°C	52°C	24°C	52°C	24°C	52°C	24°C	52°C				
DCR 0485	1									88	79	57	88
DCR 0487										153	139	99	153
DCR 0489										206	186	133	206
DCR 04811		67.0	62.0	71.0	67.5	115.0	62.0	70.5	60.0	259	227	162	259
DCR 04813										259	227	162	259
DCR 04817										259	227	162	259
DCR 04821									259	227	162	259	
DCR 0967	2									155	140	100	155
DCR 0969										240	217	155	240
DCR 09611		134.0	124.0	142.0	135.0	230.0	124.0	141.0	120.0	326	295	211	326
DCR 09613										396	358	256	396
DCR 09617									396	358	256	396	
DCR 1449	3									250	226	162	250
DCR 14411										394	356	255	394
DCR 14413		201.0	186.0	213.0	202.5	345.0	186.0	211.5	180.0	394	356	255	394
DCR 14417										394	356	255	394
DCR 19211	4									411	372	266	411
DCR 19213		268.0	248.0	284.0	270.0	460.0	248.0	282.0	240.0	509	460	329	509
DCR 19217										509	460	329	509
DCR 19221										509	460	329	509

¹⁾ Drying capacity is based on the following moisture contents before and after drying:
R22: From 1050 ppm W to 60 ppm W in accordance with ARI 710-86.
R134a: From 1050 ppm W to 75 ppm W. If refrigerant is to be dried to 50 ppm W, reduce the stated capacities by 15%.
R404A, R407C & R507: From 1020 ppm W to 30 ppm W.
R410A: From 1050 ppm W to 60 ppm W.

²⁾ Liquid capacity given in accordance with ARI 710-2002 evaporating temperature $t_e = -15^\circ\text{C}$, condensing temperature $t_c = +30^\circ\text{C}$ and pressure drop across filter drier $\Delta p = 0.07$ bar.

Capacities



Drying capacity [g of water] ³⁾

48-DA

Type	Number of cores	Evaporating temperature t_e [°C]												Acid capacity ⁴⁾ [g]
		-40	-20	4.4	-30	-20	4.4	-40	-20	4.4	-40	-20	4.4	
		R22			R134a			R404A/R507			R407C/R410A			
DCR 048	1	28	19	12	45	38	27	47	30	19	42	35	25	26.6
DCR 096	2	56	37	24	90	77	54	94	60	37	84	70	50	53.3
DCR 144	3	84	56	36	135	115	81	142	90	56	126	105	75	79.9
DCR 192	4	112	74	48	180	153	108	189	120	75	168	140	100	106.5

³⁾ Drying capacity is expressed during drying in:
 R22: EPD = 10 ppm W, corresponding to a dew point temperature = -50°C
 R134a: EPD = 50 ppm W, corresponding to a dew point temperature = -37°C
 R404A: EPD = 10 ppm W, corresponding to a dew point temperature = -40°C
 R407C: EPD = 10 ppm W, corresponding to a dew point temperature = -40°C

⁴⁾ Adsorption capacity of oleic acid at 0.05 TAN (Total Acid Number).



Recommended plant capacity [kW] ⁵⁾ in suction line - burn-out

48-DA

Type	Evaporating temperature t_e [°C]											
	-40	-20	4.4	-30	-20	4.4	-40	-20	4.4	-40	-20	4.4
	Pressure drop [Δp bar]											
	0.04	0.10	0.21	0.04	0.07	0.14	0.04	0.10	0.21	0.04	0.10	0.21
	R22			R134a			R404A/R507			R407C/R410A		
DCR 0485	3.1	8.9	21.0	3.0	5.4	13.0	2.4	7.1	17.5	3.1	8.9	21.0
DCR 0487	5.8	16.1	37.8	5.6	9.9	23.4	4.5	12.9	31.2	5.8	16.1	37.8
DCR 0489	7.8	21.6	50.7	7.5	13.3	31.5	6.0	17.2	41.8	7.8	21.6	50.7
DCR 04811	10.0	27.3	63.3	9.6	16.8	39.5	7.7	21.8	51.9	10.0	27.3	63.3
DCR 04813	10.0	27.3	63.3	9.6	16.8	39.5	7.7	21.8	51.9	10.0	27.3	63.3
DCR 04817	10.0	27.3	63.3	9.6	16.8	39.5	7.7	21.8	51.9	10.0	27.3	63.3
DCR 04821	10.0	27.3	63.3	9.6	16.8	39.5	7.7	21.8	51.9	10.0	27.3	63.3
DCR 0965	3.3	9.1	21.4	3.2	5.7	13.4	2.5	7.4	18.0	3.3	9.2	21.6
DCR 0967	5.8	16.2	38.1	5.6	9.9	23.6	4.5	12.9	31.4	5.8	16.2	38.1
DCR 0969	8.7	24.6	58.3	8.4	15.0	35.9	6.8	19.7	48.1	8.7	24.6	58.3
DCR 09611	11.9	33.4	79.3	11.4	20.4	48.9	9.3	26.8	65.4	11.9	33.4	79.3
DCR 09613	14.1	39.9	95.2	13.6	24.3	58.5	11.0	32.0	78.7	14.1	39.9	95.2
DCR 09617	14.1	39.9	95.2	13.6	24.3	58.5	11.0	32.0	78.7	14.1	39.9	95.2
DCR 09621	14.1	39.9	95.2	13.6	24.3	58.5	11.0	32.0	78.7	14.1	39.9	95.2
DCR 1445	3.5	10.0	22.8	3.4	6.0	14.0	2.7	7.7	18.9	3.5	10.0	22.8
DCR 1447	6.6	18.9	42.9	6.3	11.2	26.4	5.1	14.5	35.6	6.6	18.9	42.9
DCR 1449	8.8	25.1	57.2	8.4	15.0	35.2	6.8	19.4	47.5	8.8	25.1	57.2
DCR 14411	13.2	38.1	92.2	12.7	23.0	56.2	10.3	30.7	76.6	13.2	38.1	92.2
DCR 14413	13.2	38.1	92.2	12.7	23.0	56.2	10.3	30.7	76.6	13.2	38.1	92.2
DCR 14417	13.2	38.1	92.2	12.7	23.0	56.2	10.3	30.7	76.6	13.2	38.1	92.2
DCR 14421	13.2	38.1	92.2	12.7	23.0	56.2	10.3	30.7	76.6	13.2	38.1	92.2
DCR 1925	4.2	11.5	27.3	4.0	7.1	16.8	3.2	9.2	22.7	4.2	11.5	27.3
DCR 1927	7.9	21.6	51.4	7.6	13.4	31.6	6.1	17.4	42.7	7.9	21.6	51.4
DCR 1929	10.6	28.9	68.9	10.2	18.0	42.1	8.2	23.3	57.2	10.6	28.9	68.9
DCR 19211	14.8	41.8	99.4	14.3	25.5	61.2	11.6	33.6	82.2	14.8	41.8	99.4
DCR 19213	18.0	51.1	122.1	17.4	31.1	75.0	14.1	41.1	101.0	18.0	51.1	122.1
DCR 19217	18.0	51.1	122.1	17.4	31.1	75.0	14.1	41.1	101.0	18.0	51.1	122.1
DCR 19221	18.0	51.1	122.1	17.4	31.1	75.0	14.1	41.1	101.0	18.0	51.1	122.1

⁵⁾ Recommended plant capacity is given in accordance with ARI-Standard 710-2002 at:
 Evaporating temperature t_e = 4.4°C
 Condensing temperature t_c = 32.2°C



Strainer mounted in suction line

48-F

Refrigerant	R22			R134a			R404A/R507			R407C/R410A		
Evaporating temperature [°C]	-40	-20	4.4	-30	-20	4.4	-40	-20	4.4	-40	-20	4.4
Pressure drop [Δp bar]	0.04	0.10	0.21	0.04	0.07	0.14	0.04	0.10	0.21	0.04	0.10	0.21
Recommended plant capacity [kW]	15	47	113	15	28	69	12	38	93	15	47	113

Strainer mounted in liquid line ⁶⁾

Refrigerant	R22	R134a	R404A/R507	R407C/R410A
Recommended plant capacity [kW]	390	350	260	390

⁶⁾ Recommended plant capacity is given in accordance with ARI-Standard 710-2002 at:
 Evaporating temperature t_e = -15°C
 Condensing temperature t_c = +30°C
 Pressure drop across filter drier Δp = 0.07 bar

The data given apply to DCR 04811 with 48-F core.

Technical data and ordering

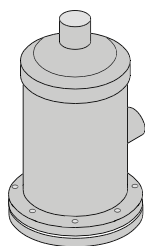

DCR housing
incl. top cover

Steel connectors

Type	Number of cores	Solder		Butt weld	Code no. ⁷⁾	Max. working pressure (PS/MWP)
		ODF in.	ODF mm	in.		
DCR 0485	1	$\frac{5}{8}$	16	$\frac{1}{2}$	023U7050	35 bar
DCR 0487		$\frac{7}{8}$	22	$\frac{3}{4}$	023U7051	
DCR 0489		$1 \frac{1}{8}$	-	1	023U7053	
DCR 04811		$1 \frac{3}{8}$	35	$1 \frac{1}{4}$	023U7054	
DCR 04813		$1 \frac{5}{8}$	-	$1 \frac{1}{2}$	023U7055	
DCR 04817		$2 \frac{1}{8}$	54	2	023U7057	
DCR 04821		$2 \frac{5}{8}$	-	$2 \frac{1}{2}$	023U7076	
DCR 0969	2	-	28	1	023U7059	
DCR 0969		$1 \frac{1}{8}$	-	1	023U7060	
DCR 09611		$1 \frac{3}{8}$	35	$1 \frac{1}{4}$	023U7061	
DCR 09613		$1 \frac{5}{8}$	-	$1 \frac{1}{2}$	023U7062	
DCR 09613		-	42	$1 \frac{1}{2}$	023U7063	
DCR 09617		$2 \frac{1}{8}$	54	2	023U7064	
DCR 1449		-	28	1	023U7065	
DCR 1449	3	$1 \frac{1}{8}$	-	1	023U7066	
DCR 14413		$1 \frac{5}{8}$	35	$1 \frac{1}{4}$	023U7068	
DCR 14413		-	42	$1 \frac{1}{2}$	023U7069	
DCR 14417		$2 \frac{1}{8}$	54	2	023U7070	
DCR 19211	4	$1 \frac{3}{8}$	35	$1 \frac{1}{4}$	023U7071	28 bar
DCR 19213		$1 \frac{5}{8}$	-	$1 \frac{1}{2}$	023U7072	
DCR 19213		-	42	$1 \frac{1}{2}$	023U7073	

Copper connectors

DCR 0485s	1	$\frac{5}{8}$	16	-	023U7250	35 bar
DCR 0487s		$\frac{7}{8}$	22	-	023U7251	
DCR 0489s		-	28	-	023U7252	
DCR 0489s		$1 \frac{1}{8}$	-	-	023U7253	
DCR 04811s		$1 \frac{3}{8}$	35	-	023U7254	
DCR 04813s		$1 \frac{5}{8}$	-	-	023U7255	
DCR 04813s		-	42	-	023U7256	
DCR 04817s		$2 \frac{1}{8}$	54	-	023U7257	
DCR 04821s		$2 \frac{5}{8}$	-	-	023U7276	
DCR 0969s		2	-	28	-	
DCR 09611s	$1 \frac{3}{8}$		35	-	023U7261	
DCR 09613s	-		42	-	023U7263	
DCR 09617s	$2 \frac{1}{8}$		54	-	023U7264	
DCR 1449s	3	-	28	-	023U7265	
DCR 14413s		-	42	-	023U7269	
DCR 14417s		$1 \frac{5}{8}$	54	-	023U7270	
DCR 19213s	4	-	42	-	023U7273	28 bar

High-pressure steel connectors

DCR 0487	1	$\frac{7}{8}$	22	$\frac{3}{4}$	023U7451	46 bar
DCR 0489		-	28	1	023U7452	
DCR0489		$1 \frac{1}{8}$	-	1	023U7453	
DCR 04811		$1 \frac{3}{8}$	35	$1 \frac{1}{4}$	023U7454	
DCR 04813		$1 \frac{5}{8}$	-	$1 \frac{1}{2}$	023U7455	
DCR 04817		$2 \frac{1}{8}$	54	2	023U7457	
DCR 0967		2	$\frac{7}{8}$	22	$\frac{3}{4}$	
DCR 0969	$1 \frac{1}{8}$		-	1	023U7459	
DCR 09611	$1 \frac{3}{8}$		35	$1 \frac{1}{4}$	023U7461	
DCR 09613	$1 \frac{5}{8}$		-	$1 \frac{1}{2}$	023U7462	
DCR 09617	$2 \frac{1}{8}$		54	2	023U7464	

DCR inserts with gasket

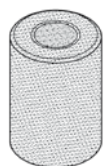

Replaceable
solid core



Strainer

Type	Material	Code no. ⁷⁾ 8 pcs.
48-DM solid core	100% molecular sieve	023U1392
48-DM solid core	100% molecular sieve (with special gasket kit)	023U1496
48-DC solid core	80% molecular sieve & 20% Al ₂ O ₃	023U4381
48-DA solid core	30% molecular sieve & 70% Al ₂ O ₃	023U5381
48-F strainer		023U1921

⁷⁾ Code numbers in bold are normally on stock and a shorter delivery time can, therefore, be expected.

DMB: Drying out in bi-flow systems

Bi-flow filter driers have built-in check valves which ensure that refrigerant liquid always flows through the filter driers from the outer side of the filter core towards the center. Thus all dirt particles are retained irrespective of flow direction.

DMB filter driers ensure fast and effective adsorption of moisture as well as organic and inorganic acids.

Features

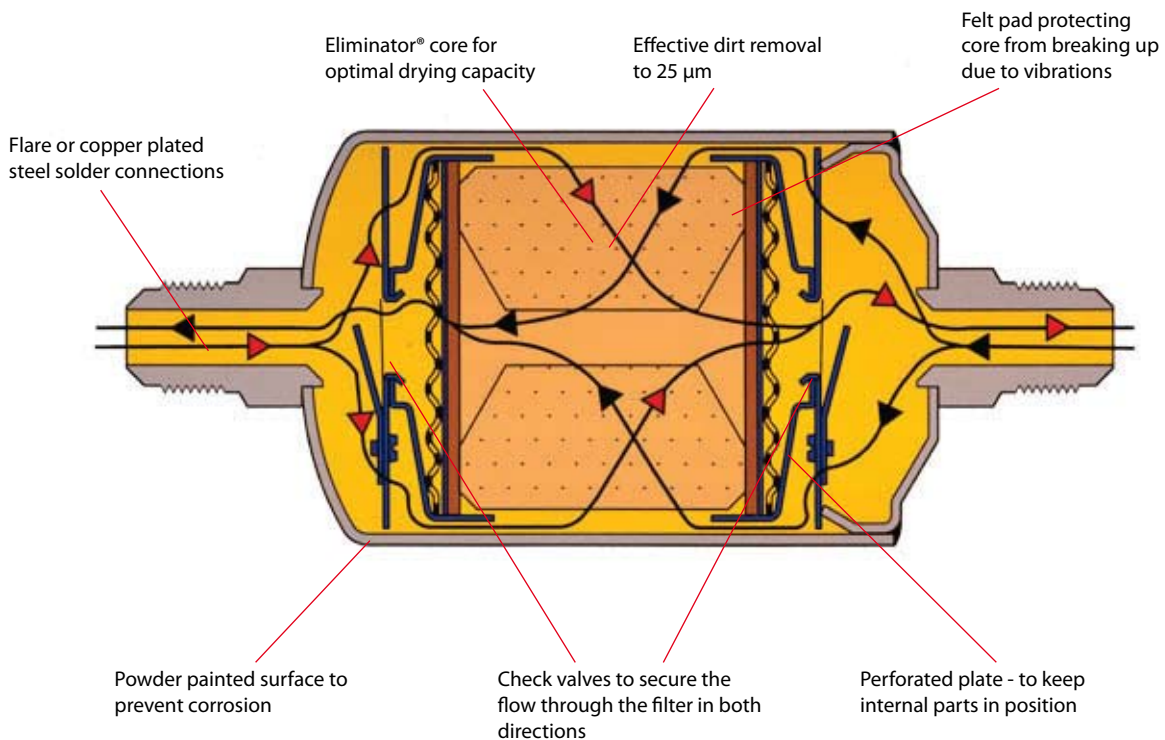

Applications	Advantages	Facts
<ul style="list-style-type: none"> Traditional refrigeration Heat pumps Air conditioning units 	<ul style="list-style-type: none"> No dirt released by reversing the flow direction The check valves are not sensitive to dirt and give minimum restriction, irrespective of flow direction When building heat pump systems, the use of Bi-flow filters can, depending on the type of system, save up to ten solder connections. This reduces production costs and the number of potential leakage points. 	<ul style="list-style-type: none"> DMB filter driers contain a solid core consisting of 100% 3Å Molecular Sieve. DMB filter driers are especially suitable for heat pumps with HFC refrigerant and polyolester oil with additives Optimum flow characteristics and dirt retention Specially designed for HCFC refrigerants and mineral oil, and also with HFC refrigerants and polyolester oil.

Technical data and ordering

Solder (Cu-plated - ODF)

Type	Conn. in.	Code no.	Conn. mm	Code no.
DMB 082s	1/4	023Z1473	6	023Z1461
DMB 083s	3/8	023Z1472	10	023Z1459
DMB 084s	1/2	023Z1471	12	023Z1457
DMB 163s	3/8	023Z1476	10	023Z1455
DMB 164s	1/2	023Z1475	12	023Z1453
DMB 165s	5/8	023Z1474	16	023Z1474
DMB 304s	1/2	023Z1479	12	023Z1451
DMB 305s	5/8	023Z1478	16	023Z1478
DMB 307s	7/8	023Z1477	22	023Z1477

Flare

Type	Conn. in.	Code no.	Code no.
DMB 082	1/4	6	023Z1412
DMB 083	3/8	10	023Z1411
DMB 084	1/2	12	023Z1410
DMB 162	1/4	6	023Z1416
DMB 163	3/8	10	023Z1415
DMB 164	1/2	12	023Z1414
DMB 165	5/8	16	023Z1413
DMB 303	3/8	10	023Z1419
DMB 304	1/2	12	023Z1418
DMB 305	5/8	16	023Z1417

Drying and liquid capacity

R134a, R507, R404A, R407C, R410A, R22

Type	Drying capacity [kg refrigerant] ¹⁾								Liquid capacity [kW] ²⁾			Max Working Pressure PS [bar]
	R134a		R404A R507		R407C R410A		R22		R134a	R404A R507	R22 R407C R410A	
	24°C	52°C	24°C	52°C	24°C	52°C	24°C	52°C				
DMB 082 / 082s									3.9	2.8	4.3	42
DMB 083 / 083s	9.2	8.5	8.7	8.1	8.0	7.3	8.7	8.0	7.4	5.3	8.2	42
DMB 084 / 084s									8.3	6.0	9.2	42
DMB 162									7.6	5.3	8.8	42
DMB 163 / 163s	17.8	16.5	16.8	15.7	15.4	14.1	16.8	15.6	18	13	20	42
DMB 164 / 164s									28	20	32	42
DMB 165 / 165s									37	29	40	42
DMB 303									19	15	21	42
DMB 304 / 304s	43.5	40.4	41.4	38.4	37.8	34.6	41.2	38.1	28	20	31	42
DMB 305 / 305s									38	28	42	42
DMB 307s									43	32	47	35

¹⁾ Drying capacity is based on following moisture content test standards before and after drying:
R134a: From 1050 ppm W to 75 ppm W. If drying to 50 ppm W is required, reduce stated capacities by 15%.
R404A, R507: From 1020 ppm W to 30 ppm W.
R407C: From 1020 ppm W to 30 ppm W.
R410A: From 1050 ppm W to 60 ppm W.
R22: From 1050 ppm W to 60 ppm W in accordance with ARI 710-86.

²⁾ Capacity given in accordance with ARI 710-86
t = -15°C (5°F)
t = 30°C (86°F)
 $\Delta p = 0.07 \text{ bar (1 psig)}$.

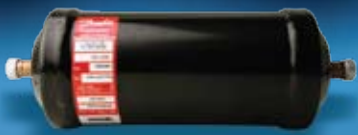

DMC: Combined filter drier and receiver

These filters contain a solid core consisting of 100% Molecular Sieve. DMC filter driers are especially suitable for A/C systems with HFC refrigerant and polyolester oil with additives. Under operating conditions where the condenser cannot contain the total quantity of refrigerant, a receiver might be necessary. This extra receiver capacity can be provided by using a DMC combined receiver and filter drier.

Features

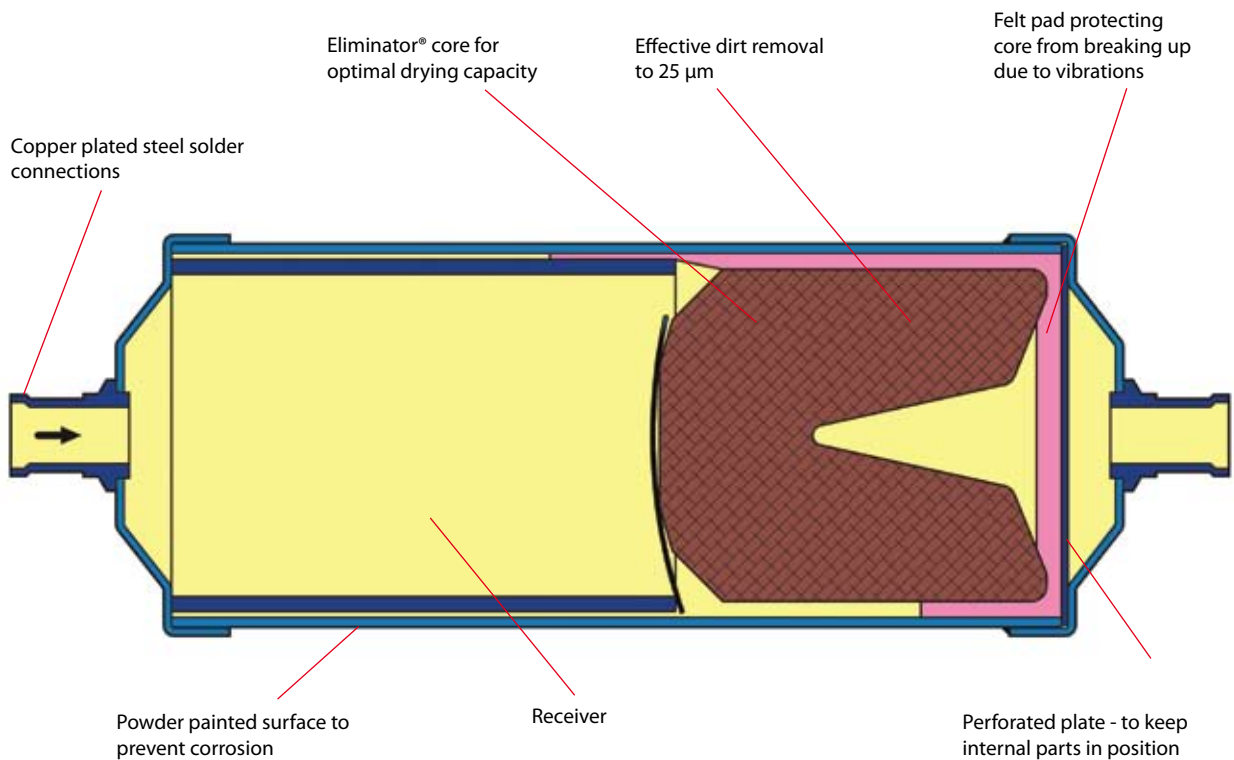

Applications	Advantages	Facts
<ul style="list-style-type: none"> • Air conditioning systems • Heat pumps 	<ul style="list-style-type: none"> • Combination of filter drier and receiver • Space-saving • Fast installation • High drying capacity at high and low liquid temperatures 	<ul style="list-style-type: none"> • DMC filter driers contain a solid core consisting of 100% 3Å Molecular Sieve. • Available with solder connections (Cu-plated steel connectors) • Optimum flow characteristics and dirt retention • Specially designed for HCFC refrigerants and mineral oil, and also with HFC refrigerants and polyolester oil. • Approved as HP container according to PED 97/23/EC - a3p3

Technical data and ordering

Type	Connections Cu-plated (ODF)	Industrial pack		Multi-pack	
		Code no.	Qty.	Code no.	Qty.
DMC 0432s	6 mm	023Z7012	16	023Z7019	28
DMC 0732s	6 mm	023Z7013	16	023Z7020	28
DMC 2032s	6 mm	023Z7007	10	023Z7021	18
DMC 2032s	1/4 in	023Z7008	10	023Z7022	18
DMC 2033s	10 mm	023Z7014	10	023Z7023	18
DMC 2033s	3/8 in	023Z7009	10	023Z7024	18
DMC 2034s	12 mm	023Z7015	10	023Z7025	18
DMC 2034s	1/2 in	023Z7010	10	023Z7026	18
DMC 40163s	10 mm	023Z7016	6	023Z7027	10
DMC 40163s	3/8 in	023Z7017	6	023Z7028	10
DMC 40164s	12 mm	023Z7018	6	023Z7029	10
DMC 40164s	1/2 in	023Z7011	6	023Z7030	10

Capacity

Drying and liquid capacity

R134a, R507, R404A, R407C, R410A, R22

Type	Drying Capacity (kg of refrigerant) ¹⁾								Liquid Capacity (kW) ²⁾			Max. Working Pressure PS [bar]
	R410A R407C		R22		R134a		R404A R507		R22 R410A R407C	R134a	R404A R507	
	24°C	52°C	24°C	52°C	24°C	52°C	24°C	52°C				
DMC 0432s	5.9	5.4	6.4	5.9	6.4	5.9	6.3	6.0	7.5	7.0	5.0	42
DMC 0732s	5.9	5.4	6.4	5.9	6.4	5.9	6.3	6.0	7.5	7.0	5.0	42
DMC 2032s	5.9	5.4	6.4	5.9	6.4	5.9	6.3	6.0	7.5	7.0	5.0	42
DMC 2033s									21.0	19.0	14.0	
DMC 2034s									26.5	24.0	18.5	
DMC 40163s	25.8	23.7	28.1	26.0	28.3	26.0	27.8	26.2	23.0	21.0	15.0	42
DMC 40164s									28.5	26.0	19.5	

¹⁾ Drying capacity is based on following moisture content in the refrigerant before and after drying:

R22:

From 1050 ppm W to 60 ppm W in accordance with ARI 710-86.

R134a:

From 1050 ppm W to 75 ppm W. If drying of refrigerant to 50 ppm W is required, this can be achieved with a 15% reduction of the stated capacities.

R404A, R407C og R507:

From 1020 ppm W to 30 ppm W.

R410A:

From 1050 ppm W to 60 ppm W.

²⁾ Given in accordance with

ARI 710-86 for

$t_e = -15^\circ\text{C}$ (5°F),

$t_c = 30^\circ\text{C}$ (86°C) and

$\Delta p = 0.07$ bar (1 psig).



DAS: Clean up your refrigerant

Eliminator burn-out filter driers type DAS are used in the suction line to clean up refrigeration and AC-systems with fluorinated refrigerants after a compressor motor burn-out. The solid core, which is composed of 70% activated alumina and 30% Molecular Sieve, adsorbs harmful acids as well as moisture. By adsorbing these acids, the DAS burn-out filter drier protects the new compressor against premature failure.

Features

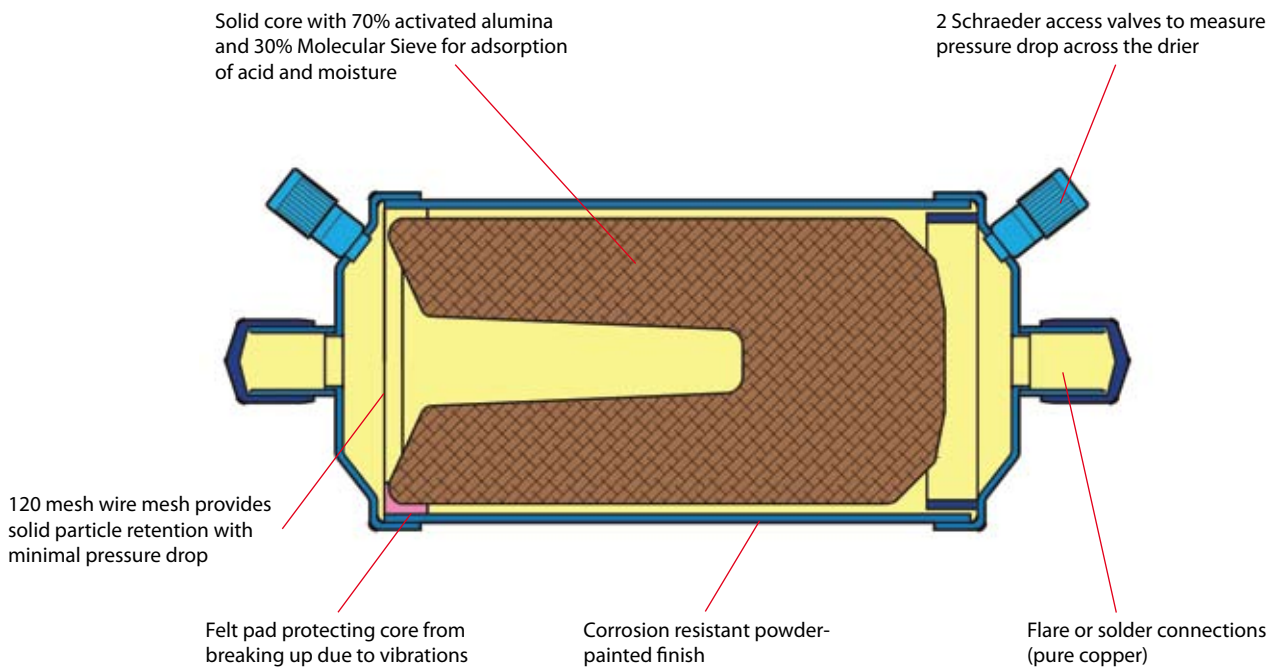

Applications	Advantages	Facts
<ul style="list-style-type: none"> · Traditional refrigeration · Air conditioning units · Transport refrigeration 	<ul style="list-style-type: none"> · The large diameter of the burn-out filter drier means that flow velocity is suitably low and the pressure drop minimal. · Powder formation is eliminated because the solid core grains are bonded and cannot move against each other. 	<ul style="list-style-type: none"> · Allows installation with any orientation provided the flow is in the arrow direction · Available in sizes from 8 to 60 cubic inches · For use with CFC, HCFC and HFC refrigerants

Technical data and ordering

Ordering

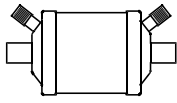

Flare

Type	Connection in.	Code no.
DAS 083	3/8	023Z1001
DAS 084	1/2	023Z1002
DAS 164	1/2	023Z1007
DAS 165	5/8	023Z1008

Solder

Type	Connection in.	Code no.
DAS 083	3/8	023Z1003
DAS 084	1/2	023Z1004
DAS 085	5/8	023Z1005
DAS 086	3/4	023Z1006
DAS 164	1/2	023Z1009
DAS 165	5/8	023Z1010
DAS 166	3/4	023Z1011
DAS 167	7/8	023Z1012
DAS 305	5/8	023Z1013
DAS 306	3/4	023Z1014
DAS 307	7/8	023Z1015
DAS 309	1 1/8	023Z1016
DAS 417	7/8	023Z1017
DAS 419	1 1/8	023Z1018
DAS 607	7/8	023Z1019
DAS 609	1 1/8	023Z1020

Capacities

	Rated capacity, Q_n ¹⁾						Acid capacity ²⁾
	R22/R407C/R410A		R134a		R404A/R507		[g]
	[TR]	[kW]	[TR]	[kW]	[TR]	[kW]	
DAS 083	1.7	6.0	1.0	3.5	1.3	4.5	3.8
DAS 084	2.9	10.0	1.6	5.5	2.3	8.0	
DAS 085	4.1	14.5	2.6	9.0	3.6	12.5	
DAS 086	5.4	19.0	3.3	11.5	4.7	16.5	
DAS 164	3.0	10.5	1.7	6.0	2.4	8.5	8.6
DAS 165	4.3	15.0	2.7	9.5	3.7	13.0	
DAS 166	5.7	20.0	3.4	12.0	4.9	17.0	
DAS 167	6.3	22.0	3.9	13.5	5.4	19.0	
DAS 305	5.1	18.0	3.1	11.0	4.3	15.0	18.2
DAS 306	6.3	22.0	4.0	14.0	5.4	19.0	
DAS 307	7.4	26.0	4.6	16.0	6.3	22.0	
DAS 309	8.9	31.0	5.7	20.0	7.7	27.0	
DAS 417	8.6	30.0	5.1	18.0	7.1	25.0	24.3
DAS 419	10.0	35.0	6.3	22.0	8.6	30.0	
DAS 607	5.7	20.0	3.4	12.0	4.9	17.0	36.5

¹⁾ Rated capacity is stated at: evaporating temperature $t_e = 4^\circ\text{C}$ pressure drop $\Delta p = 0.21 \text{ bar}$

²⁾ Adsorption capacity of oleic acid at 0.05 TAN (Total Acid Number).

Capacities for other temperatures than 4°C are calculated by use of correction factors. Divide your actual evaporator capacity with the correction factor given for your actual evaporating temperature.

Look up the capacity table for the necessary rated capacity.

$$Q_e / F_e = Q_n$$

Q_e = Actual evaporator capacity

Q_n = Nominal capacity

F_e = Correction factor

Correction factors. F_e evaporating temperatures $[\text{C}]$

$[\text{C}]$	4	0	-5	-10	-15	-20	-25	-30	-35	-40
F_e	1	0.9	0.75	0.6	0.5	0.4	0.35	0.25	0.2	0.15

Example

To select a burn-out filter drier for a R22 plant with an evaporator capacity at 8.5 kW at -20°C you may use a burn-out filter drier with a rated capacity of $8.5/0.4 = 21.25 \text{ kW}$ or bigger.

For example DAS 306.



SVA - Stop valves

SVA are angleway and straightway stop valves which are designed to meet all industrial refrigeration application requirements. The valves are designed to give favourable flow characteristics and are easy to dismantle and repair when necessary. The valve cone is designed to ensure perfect closing.



Advantages and features

- Applicable to all common refrigerants including R717 and non corrosive gases/liquids
- Optional accessories:
 - Heavy duty industrial hand wheel for frequent operation
 - Cap for infrequent operation
 - Lock washers for the stop valves subjected to high vibrations/pulsations
- The valves and caps are prepared for sealing, to prevent operation by unauthorized persons, using a seal wire
- Standard bonnet is suitable for installation in normal insulated systems
- SVA-HS valves has an extended bonnet, suitable for insulated low temperature applications.
- Internal metal backseating - DN 6 - 65 (1/4 - 2½ in.)
Internal PTFE backseating - DN 80 - 300 (3 - 12 in.)
- Accepts flow in both directions
- Housing and bonnet material for SVA-ST, -DL, -DH and HS is low temperature steel according to requirements of the Pressure Equipment Directive and other international classification authorities.
SVA-SS housing material is special cold resistant stainless steel approved for low temperature operations
- Exact capacity and setting of the valve can be calculated for all refrigerants by means of DIRcalc™ (Danfoss Industrial Refrigeration calculation programme). Please contact your local Danfoss Sales Company to have your own copy of DIRcalc™.
- Classification:
To get an updated list of certification on the products please contact your local Danfoss Sales Company.

Technical data and code numbers

The SVA stop valve range cover valves from DN 6 (¼ in.) up to DN 300 (12 in.)

- SVA-ST is the Danfoss standard industrial valve series up to DN 200.
- SVA-DL and SVA-DH are the large industrial valves with a balanced design that allows opening of the valves with a limited torque. Sizes from DN 250 (10 in.) up to DN 300 (12 in.)
- SVA-HS is the Danfoss valve series with higher specification for i.e. the petrochemical industry.
- SVA-SS is the Danfoss stainless steel industrial valve series.

Technical data

	SVA 6 - 10 and SVA-ST	SVA-HS	SVA -DI and SVA-DH	SVA - SS
Refrigerants	Applicable to all common non flammable refrigerants including R717 and non corrosive gases/liquids	Applicable to all common refrigerants including flammable hydrocarbons and all non-corrosive gases/liquids.	Applicable to all common non flammable refrigerants including R717 and non corrosive gases/liquids	Applicable to all common non flammable refrigerants including R717 and non corrosive gases/liquids
Temperature range	-50/+150°C	-60/+150°C	-60/+150°C	-60/+150°C
Pressure range	The valves are designed for max. working pressure 40 bar g. Valves for higher working pressure are available on request.	The valves are designed for max. working pressure 40 bar g. Valves for higher working pressure are available on request.	The valves are designed for max. working pressure 40 bar g. Valves for higher working pressure are available on request.	Are designed for max. working pressure 52 bar.

For further information please see installation instructions for SVA-ST, HS and SS or for SVA - DL and SVA - DH

Code numbers

SVA-ST stop valves:

DIN Size		Angleway		DIN Size		Straightway	
mm	in.	Type	Code number	mm	in.	Type	Code number
15	½	SVA-ST 15 D ANG H-Wheel	148B3361	15	½	SVA-ST 15 D STR H-Wheel	148B3401
15	½	SVA-ST 15 D ANG Cap	148B3362	15	½	SVA-ST 15 D STR Cap	148B3402
20	¾	SVA-ST 20 D ANG H-Wheel	148B3441	20	¾	SVA-ST 20 D STR H-Wheel	148B3481
20	¾	SVA-ST 20 D ANG Cap	148B3442	20	¾	SVA-ST 20 D STR Cap	148B3482
25	1	SVA-ST 25 D ANG H-Wheel	148B3521	25	1	SVA-ST 25 D STR H-Wheel	148B3561
25	1	SVA-ST 25 D ANG Cap	148B3522	25	1	SVA-ST 25 D STR Cap	148B3562
32	1¼	SVA-ST 32 D ANG H-Wheel	148B3601	32	1¼	SVA-ST 32 D STR H-Wheel	148B3641
32	1¼	SVA-ST 32 D ANG Cap	148B3602	32	1¼	SVA-ST 32 D STR Cap	148B3642
40	1½	SVA-ST 40 D ANG H-Wheel	148B3681	40	1½	SVA-ST 40 D STR H-Wheel	148B3711
40	1½	SVA-ST 40 D ANG Cap	148B3682	40	1½	SVA-ST 40 D STR Cap	148B3712
50	2	SVA-ST 50 D ANG H-Wheel	148B3032	50	2	SVA-ST 50 D STR H-Wheel	148B3038
50	2	SVA-ST 50 D ANG Cap	148B3033	50	2	SVA-ST 50 D STR Cap	148B3039
65	2½	SVA-ST 65 D ANG H-Wheel	148B3044	65	2½	SVA-ST 65 D STR H-Wheel	148B3050
65	2½	SVA-ST 65 D ANG Cap	148B3045	65	2½	SVA-ST 65 D STR Cap	148B3051
80	3	SVA-ST 80 D ANG H-Wheel	148B3061	80	3	SVA-ST 80 D STR H-Wheel	148B3081
80	3	SVA-ST 80 D ANG Cap	148B3062	80	3	SVA-ST 80 D STR Cap	148B3082
100	4	SVA-ST 100 D ANG H-Wheel	148B3101	100	4	SVA-ST 100 D STR H-Wheel	148B3121
100	4	SVA-ST 100 D ANG Cap	148B3102	100	4	SVA-ST 100 D STR Cap	148B3122
125	5	SVA-ST 125 D ANG H-Wheel	148B3141	125	5	SVA-ST 125 D STR H-Wheel	148B3161
125	5	SVA-ST 125 D ANG Cap	148B3142	125	5	SVA-ST 125 D STR Cap	148B3162
150	6	SVA-ST 150 D ANG H-Wheel	148B3181	150	6	SVA-ST 150 D STR H-Wheel	148B3201
150	6	SVA-ST 150 D ANG Cap	148B3182	150	6	SVA-ST 150 D STR Cap	148B3202
200	8	SVA-ST 200 D ANG H-Wheel	148B3221	200	8	SVA-ST 200 D STR H-Wheel	148B3241
200	8	SVA-ST 200 D ANG Cap	148B3222	200	8	SVA-ST 200 D STR Cap	148B3242

SVA-DL stop valves:

DIN Size		Type	Code number
mm	in.		
250	10	SVA-DL 250 D CAP	148B3760
250	10	SVA-DL 250 D H-HEEL	148B3761
300	12	SVA-DL 300 D CAP	148B3770
300	12	SVA-DL 300 D H-WHEEL	148B3771

SVA-DH stop valves:

DIN Size		Type	Code number
mm	in.		
250	10	SVA-DH 250 D CAP	148B3764
250	10	SVA-DH 250 D H-WHEEL	148B3765
300	12	SVA-DH 300 D CAP	148B3774
300	12	SVA-DH 300 D H-WHEEL	148B3775

Code numbers

SVA-HS stop valves:

DIN Size		Angleyway		DIN Size		Straightway	
mm	in.	Type	Code number	mm	in.	Type	Code number
15	½	SVA-HS 15 D ANG H-Wheel	148B3367	15	½	SVA-HS 15 D STR H-Wheel	148B3407
15	½	SVA-HS 15 D ANG Cap	148B3368	15	½	SVA-HS 15 D STR Cap	148B3408
20	¾	SVA-HS 20 D ANG H-Wheel	148B3447	20	¾	SVA-HS 20 D STR H-Wheel	148B3487
20	¾	SVA-HS 20 D ANG Cap	148B3448	20	¾	SVA-HS 20 D STR Cap	148B3488
25	1	SVA-HS 25 D ANG H-Wheel	148B3527	25	1	SVA-HS 25 D STR H-Wheel	148B3567
25	1	SVA-HS 25 D ANG Cap	148B3528	25	1	SVA-HS 25 D STR Cap	148B3568
32	1¼	SVA-HS 32 D ANG H-Wheel	148B3607	32	1¼	SVA-HS 32 D STR H-Wheel	148B3647
32	1¼	SVA-HS 32 D ANG Cap	148B3608	32	1¼	SVA-HS 32 D STR Cap	148B3648
40	1½	SVA-HS 40 D ANG H-Wheel	148B3687	40	1½	SVA-HS 40 D STR H-Wheel	148B3717
40	1½	SVA-HS 40 D ANG Cap	148B3688	40	1½	SVA-HS 40 D STR Cap	148B3718
50	2	SVA-HS 50 D ANG H-Wheel	148B3267	50	2	SVA-HS 50 D STR H-Wheel	148B3297
50	2	SVA-HS 50 D ANG Cap	148B3268	50	2	SVA-HS 50 D STR Cap	148B3298
65	2½	SVA-HS 65 D ANG H-Wheel	148B3327	65	2½	SVA-HS 65 D STR H-Wheel	148B3347
65	2½	SVA-HS 65 D ANG Cap	148B3328	65	2½	SVA-HS 65 D STR Cap	148B3348
80	3	SVA-HS 80 D ANG H-Wheel	148B3067	80	3	SVA-HS 80 D STR H-Wheel	148B3087
80	3	SVA-HS 80 D ANG Cap	148B3068	80	3	SVA-HS 80 D STR Cap	148B3088
100	4	SVA-HS 100 D ANG H-Wheel	148B3107	100	4	SVA-HS 100 D STR H-Wheel	148B3127
100	4	SVA-HS 100 D ANG Cap	148B3108	100	4	SVA-HS 100 D STR Cap	148B3128
125	5	SVA-HS 125 D ANG H-Wheel	148B3147	125	5	SVA-HS 125 D STR H-Wheel	148B3167
125	5	SVA-HS 125 D ANG Cap	148B3148	125	5	SVA-HS 125 D STR Cap	148B3168
150	6	SVA-HS 150 D ANG H-Wheel	148B3187	150	6	SVA-HS 150 D STR H-Wheel	148B3207
150	6	SVA-HS 150 D ANG Cap	148B3188	150	6	SVA-HS 150 D STR Cap	148B3208
200	8	SVA-HS 200 D ANG H-Wheel	148B3227	200	8	SVA-HS 200 D STR H-Wheel	148B3247
200	8	SVA-HS 200 D ANG Cap	148B3228	200	8	SVA-HS 200 D STR Cap	148B3248

SVA-SS (stainless steel) stop valves

15	½	SVA-SS 15 D ANG Cap 52 bar	148B3843	15	½	SVA-SS 15 D STR Cap 52 bar	148B4249
15	½	SVA-SS 15 D ANG H-Wheel 52 bar	148B3844	15	½	SVA-SS 15 D STR H-Wheel 52 bar	148B4250
20	¾	SVA-SS 20 D ANG Cap 52 bar	148B3845	20	¾	SVA-SS 20 D STR Cap 52 bar	148B4251
20	¾	SVA-SS 20 D ANG H-Wheel 52 bar	148B3846	20	¾	SVA-SS 20 D STR H-Wheel 52 bar	148B4252
25	1	SVA-SS 25 D ANG Cap 52 bar	148B3847	25	1	SVA-SS 25 D STR Cap 52 bar	148B4253
25	1	SVA-SS 25 D ANG H-Wheel 52 bar	148B3848	25	1	SVA-SS 25 D STR H-Wheel 52 bar	148B4254
32	1¼	SVA-SS 32 D ANG Cap 52 bar	148B3849	32	1¼	SVA-SS 32 D STR Cap 52 bar	148B4255
32	1¼	SVA-SS 32 D ANG H-Wheel 52 bar	148B3850	32	1¼	SVA-SS 32 D STR H-Wheel 52 bar	148B4256
40	1½	SVA-SS 40 D ANG Cap 52 bar	148B3851	40	1½	SVA-SS 40 D STR Cap 52 bar	148B4257
40	1½	SVA-SS 40 D ANG H-Wheel 52 bar	148B3852	40	1½	SVA-SS 40 D STR H-Wheel 52 bar	148B4258
50	2	SVA-SS 50 D ANG Cap 52 bar	148B3853	50	2	SVA-SS 50 D STR Cap 52 bar	148B4259
50	2	SVA-SS 50 D ANG H-Wheel 52 bar	148B3854	50	2	SVA-SS 50 D STR H-Wheel 52 bar	148B4260
65	2½	SVA-SS 65 D ANG Cap 52 bar	148B3855	65	2½	SVA-SS 65 D STR Cap 52 bar	148B4261
65	2½	SVA-SS 65 D ANG H-Wheel 52 bar	148B3856	65	2½	SVA-SS 65 D STR H-Wheel 52 bar	148B4262

- Example: SVA-HS 32 DIN angleyway with hand wheel = **148B3607**

- **Important!** Where products need to be certified according to specific certification societies or where higher pressures are required, the relevant information should be included at the time of order

- For a complete range of valves with ANSI, Socket and threaded connection please see the technical leaflet for further information and code numbers

- D = Butt-weld DIN, ANG= Angle-way, STR = Straight-way, Cap = Cap, H-Wheel = Hand wheel



REG and REG-SS - Regulating valves

REG and REG-SS are regulating valves which are available as angle-way and straight-way valves. When they are in closed position they act as a normal stop valve. The valves are designed to meet the strict quality requirements on refrigerating installations specified by the international classification societies and are carefully designed to present favourable flow conditions and accurate linear characteristics. REG are equipped with vented cap and have internal backseating enabling the spindle seal to be replaced with the valve still under pressure.

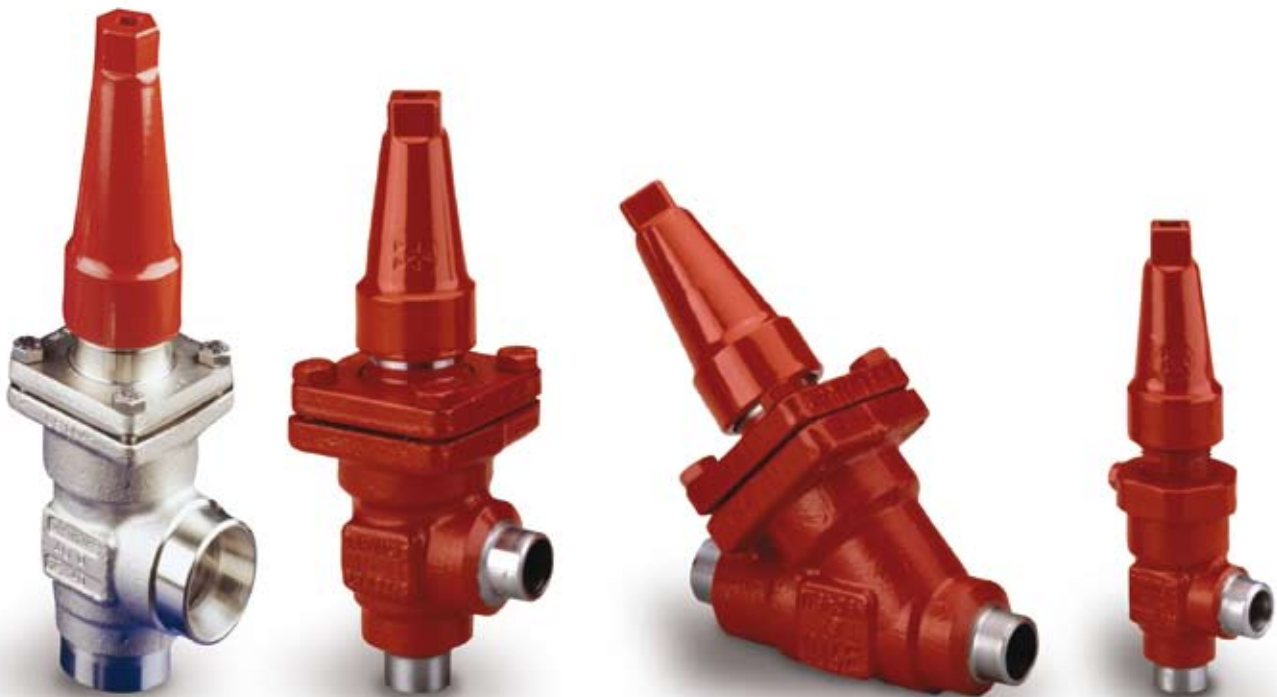

Advantages and features

- Applicable to all common non flammable refrigerants including R 717 and non corrosive gases/liquids.
- Designed to ensure perfect regulation.
- Internal backseating enables replacement of the spindle seal whilst the valve is active, i.e. under pressure.
- Easy to disassemble for inspection and possible repair.
- Act as a normal stop valve in closed position.
- Housing and bonnet material is low temperature steel according to requirements of the Pressure Equipment Directive and other international classification authorities. REG-SS housing material in special cold resistant stainless steel approved for low temperature operations.
- Exact capacity and setting of the valve can be calculated for all refrigerants by means of "DIRcalc™" (Danfoss Industrial Refrigeration calculation programme). Please contact your local Danfoss Sales Company to have your own copy of DIRcalc.
- Classification: To get an updated list of certification on the products please contact your local Danfoss Sales Company.

Technical data and code numbers

Technical data

	REG	REG-SS
Flow coefficients	Flow coefficients for fully opened valves from $k_v = 0.17$ to $81.4 \text{ m}^3/\text{h}$	Flow coefficients for fully opened valves from $k_v = 0.17$ to $81.4 \text{ m}^3/\text{h}$
Temperature range	-50/+150°C	-60/+150°C
Pressure range Max. operating pressure	40 bar g	52 bar g

Please see the technical leaflet for further details
Valves for higher working pressure are available on request.

Code numbers

DIN		Angleway	
Size		Type designation	Code number
mm	in.		
6	¼	REG 6 D ANG CONE#1	2415+426
6	¼	REG 6 D ANG CONE#2	2415+427
6	¼	REG 6 D ANG CONE#3	2415+428
10	⅜	REG 10 D ANG CONE#1	2415+432
10	⅜	REG 10 D ANG CONE#2	2415+433
10	⅜	REG 10 D ANG CONE#3	2415+434
15	½	REG 15 D ANG CONE#3	2415+883
15	½	REG 15 D ANG CONE#4	148G3239
15	½	REG 15 D ANG CONE#5	148G3240
15	½	REG 15 D ANG CONE#6	148G3241
15	½	REG 15 D ANG CONE#7	148G3242
20	¾	REG 20 D ANG CONE#4	148G3247
20	¾	REG 20 D ANG CONE#5	148G3248
20	¾	REG 20 D ANG CONE#6	148G3249
20	¾	REG 20 D ANG CONE#7	148G3250
25	1	REG 25 D ANG CONE#4	148G3255
25	1	REG 25 D ANG CONE#5	148G3256
25	1	REG 25 D ANG CONE#6	148G3257
25	1	REG 25 D ANG CONE#7	148G3258
32	1¼	REG 32 D ANG CONE#8	148G3263
32	1¼	REG 32 D ANG CONE#9	148G3264
32	1¼	REG 32 D ANG CONE#10	148G3265
40	1½	REG 40 D ANG CONE#8	148G3269
40	1½	REG 40 D ANG CONE#9	148G3270
40	1½	REG 40 D ANG CONE#10	148G3271
50	2	REG 50 D ANG CONE#11	148G3485
65	2½	REG 65 D ANG CONE#12	148G3486

DIN		Straightway	
Size		Type	Code number
mm	in.		
6	¼	REG 6 D STR CONE#1	2415+429
6	¼	REG 6 D STR CONE#2	2415+430
6	¼	REG 6 D STR CONE#3	2415+431
10	⅜	REG 10 D STR CONE#1	2415+435
10	⅜	REG 10 D STR CONE#2	2415+436
10	⅜	REG 10 D STR CONE#3	2415+437
15	½	REG 15 D STR CONE#4	148G3243
15	½	REG 15 D STR CONE#5	148G3244
15	½	REG 15 D STR CONE#6	148G3245
15	½	REG 15 D STR CONE#7	148G3246
20	¾	REG 20 D STR CONE#4	148G3251
20	¾	REG 20 D STR CONE#5	148G3252
20	¾	REG 20 D STR CONE#6	148G3253
20	¾	REG 20 D STR CONE#7	148G3254
25	1	REG 25 D STR CONE#4	148G3259
25	1	REG 25 D STR CONE#5	148G3260
25	1	REG 25 D STR CONE#6	148G3261
25	1	REG 25 D STR CONE#7	148G3262
32	1¼	REG 32 D STR CONE#8	148G3266
32	1¼	REG 32 D STR CONE#9	148G3267
32	1¼	REG 32 D STR CONE#10	148G3268
40	1½	REG 40 D STR CONE#8	148G3273
40	1½	REG 40 D STR CONE#9	148G3274
40	1½	REG 40 D STR CONE#10	148G3275

REG valves in stainless steel

DIN		Angleway	
Size		Type designation	Code number
mm	in.		
15	½	REG-SS 15 D ANG CONG#4 Reg valve 52 bar	148G3542
15	½	REG-SS 15 D ANG CONG#5 Reg valve 52 bar	148G3543
15	½	REG-SS 15 D ANG CONG#6 Reg valve 52 bar	148G3544
15	½	REG-SS 15 D ANG CONG#7 Reg valve 52 bar	148G3545
20	¾	REG-SS 20 D ANG CONG#4 Reg valve 52 bar	148G3546
20	¾	REG-SS 20 D ANG CONG#5 Reg valve 52 bar	148G3547
20	¾	REG-SS 20 D ANG CONG#6 Reg valve 52 bar	148G3548
20	¾	REG-SS 20 D ANG CONG#7 Reg valve 52 bar	148G3549
25	1	REG-SS 25 D ANG CONG#4 Reg valve 52 bar	148G3550
25	1	REG-SS 25 D ANG CONG#5 Reg valve 52 bar	148G3551
25	1	REG-SS 25 D ANG CONG#6 Reg valve 52 bar	148G3552
25	1	REG-SS 25 D ANG CONG#7 Reg valve 52 bar	148G3553
32	1¼	REG-SS 32 D ANG CONG#8 Reg valve 52 bar	148G3555
32	1¼	REG-SS 32 D ANG CONG#9 Reg valve 52 bar	148G3556
32	1¼	REG-SS 32 D ANG CONG#10 Reg valve 52 bar	148G3554
40	1½	REG-SS 40 D ANG CONG#8 Reg valve 52 bar	148G3558
40	1½	REG-SS 40 D ANG CONG#9 Reg valve 52 bar	148G3559
40	1½	REG-SS 40 D ANG CONG#10 Reg valve 52 bar	148G3557

DIN		Straightway	
Size		Type designation	Code number
mm	in.		
15	½	REG-SS 15 D STR CONG#4 Reg valve 52 bar	148G3640
15	½	REG-SS 15 D STR CONG#5 Reg valve 52 bar	148G3641
15	½	REG-SS 15 D STR CONG#6 Reg valve 52 bar	148G3642
15	½	REG-SS 15 D STR CONG#7 Reg valve 52 bar	148G3643
20	¾	REG-SS 20 D STR CONG#4 Reg valve 52 bar	148G3644
20	¾	REG-SS 20 D STR CONG#5 Reg valve 52 bar	148G3645
20	¾	REG-SS 20 D STR CONG#6 Reg valve 52 bar	148G3646
20	¾	REG-SS 20 D STR CONG#7 Reg valve 52 bar	148G3647
25	1	REG-SS 25 D STR CONG#4 Reg valve 52 bar	148G3648
25	1	REG-SS 25 D STR CONG#5 Reg valve 52 bar	148G3649
25	1	REG-SS 25 D STR CONG#6 Reg valve 52 bar	148G3650
25	1	REG-SS 25 D STR CONG#7 Reg valve 52 bar	148G3651
32	1¼	REG-SS 32 D STR CONG#8 Reg valve 52 bar	148G3653
32	1¼	REG-SS 32 D STR CONG#9 Reg valve 52 bar	148G3654
32	1¼	REG-SS 32 D STR CONG#10 Reg valve 52 bar	148G3652
40	1½	REG-SS 40 D STR CONG#8 Reg valve 52 bar	148G3656
40	1½	REG-SS 40 D STR CONG#9 Reg valve 52 bar	148G3657
40	1½	REG-SS 40 D STR CONG#10 Reg valve 52 bar	148G3655

- Example: REG 15 DIN angleway with cone no. 7 = 148G3242

- **Important!** Where products need to be certified according to specific certification societies or where higher pressures are required, the relevant information should be included at the time of ordering.

- To find the complete range of valves with ANSI, socket and threaded connections please study the technical leaflet for further information and code numbers.

- D = Butt-weld DIN A = ANSI ANG= Angle-way STR = Straight-way



FIA, FIA-SS - Filters

FIA filters are a range of angle-way and straight-way filters which are carefully designed to give favourable flow conditions. The design makes the filter easy to install, and ensures quick filter inspection and cleaning.

FIA filters are used ahead of automatic controls, pumps, compressors etc. for initial plant start-up and where permanent filtration of the refrigerant is required. The filter reduces the risk of undesirable system breakdowns and reduces wear and tear on plant components.



Advantages and features

- Applicable to all common refrigerants including R717 and non corrosive gasses/liquids
- FIA filters are sold as a parts programme, where filter housing and filter element is ordered as separate code numbers. This gives a high degree of flexibility
- The filter elements, which are made of stainless steel can be mounted in the filter housing without extra gaskets, which means easy service
- Two types of filter elements are available:
 - A plain filter element of stainless steel for all sizes
 - A pleated filter element (DN 15-200) with extra large surface, which ensures long intervals between cleaning and low pressure drop
- FIA 15-40 (½ – 1 ½ in.): A special insert (50µ) can be used in combination with a standard version when cleaning a plant during commissioning and start up
- FIA 50 - 200 (2 - 10 in.) can be equipped with a large capacity filter bag (50µ) can be inserted for cleaning plant during commissioning and start up
- FIA 50 - 200 (2 - 10 in.) can be equipped with a magnetic insert for detension of iron particles and other magnetic particles
- Each filter housing is clearly marked with type, size and performance range
- The filter housing is made of low temperature steel (FIA) or stainless steel (FIA-SS) in accordance with the requirements of the Pressure Equipment Directive and those of other international classification authorities

* Mesh is the number of threads per inch.
 µ (microns) is the distance between two threads
 (1µ = 1 /1000 mm).

Technical data, code numbers and accessories

Technical data

	FIA	FIA-SS
Refrigerants	Applicable to all common refrigerants including flammable refrigerants and all non-corrosive gases/liquids.	Applicable to all common refrigerants including flammable refrigerants and all non-corrosive gases/liquids.
Temperature range	-60°C/+150°C	-60°C/+150°C
Pressure range Max. working pressure	40 bar g	52 bar g

For further information please see installation instruction for FIA.

Code numbers

Size		Type	Filter housing without filter element	Filter element	Filter element	Filter element	Filter element	Pleated filter element	Pleated filter element	Pleated filter element
mm	in.			100µ 150 mesh	150µ 100 mesh	250µ 72 mesh	500µ 38 mesh	150µ 100 mesh	250µ 72 mesh	500µ 38 mesh
15	½	FIA 15 D ANG	148H3051	148H3122	148H3124	148H3126	148H3128	148H3303	-	-
15	½	FIA 15 D STR	148H3085							
20	¾	FIA 20 D ANG	148H3052							
20	¾	FIA 20 D STR	148H3086							
25	1	FIA 25 D ANG	148H3053	148H3123	148H3125	148H3127	148H3129	148H3304	148H3269	-
25	1	FIA 25 D STR	148H3087							
32	1¼	FIA 32 D ANG	148H3054							
32	1¼	FIA 32 D STR	148H3088							
40	1½	FIA 40 D ANG	148H3055	148H3157	148H3130	148H3138	148H3144	148H3179	148H3184	148H3189
40	1½	FIA 40 D STR	148H3089							
50	2	FIA 50 D ANG	148H3056							
50	2	FIA 50 D STR	148H3090							
65	2½	FIA 65 D ANG	148H3057	-	148H3131	148H3139	148H3145	148H3180	148H3185	148H3190
65	2½	FIA 65 D STR	148H3091	-	148H3119	148H3120	148H3121	148H3181	148H3186	148H3191
80	3	FIA 80 D ANG	148H3058	-	148H3119	148H3120	148H3121	148H3181	148H3186	148H3191
80	3	FIA 80 D STR	148H3092	-	148H3132	148H3140	148H3146	148H3182	148H3187	148H3192
100	4	FIA 100 D ANG	148H3059	-	148H3132	148H3140	148H3146	148H3182	148H3187	148H3192
100	4	FIA 100 D STR	148H3093	-	148H3133	148H3141	148H3147	148H3183	148H3188	148H3193
125	5	FIA 125 D ANG	148H3060	-	148H3133	148H3141	148H3147	148H3183	148H3188	148H3193
125	5	FIA 125 D STR	148H3094	-	148H3134	148H3142	148H3148	148H3226	-	-
150	6	FIA 150 D ANG	148H3061	-	148H3134	148H3142	148H3148	148H3226	-	-
150	6	FIA 150 D STR	148H3095	-	148H3135	148H3143	148H3149	-	-	-
200	8	FIA 200 D ANG	148H3062	-	148H3135	148H3143	148H3149	-	-	-
200	8	FIA 200 D STR	148H3096	-	148H3135	148H3143	148H3149	-	-	-
250	10	FIA 250 D ANG	148H3171	-	148H3136	148H3175	148H3177	-	-	-
300	12	FIA 300 D ANG	148H3172	-	148H3137	148H3176	148H3178	-	-	-

FIA filters in stainless steel

FIA-SS Straight flow

Size		Type designation	Code number
mm	in.		
15	½	FIA-SS 15 D STR Filter Housing 52 bar	148H3285
20	¾	FIA-SS 20 D STR Filter Housing 52 bar	148H3286
25	1	FIA-SS 25 D STR Filter Housing 52 bar	148H3287
32	1¼	FIA-SS 32 D STR Filter Housing 52 bar	148H3288
40	1½	FIA-SS 40 D STR Filter Housing 52 bar	148H3289
50	2	FIA-SS 50 D STR Filter Housing 52 bar	148H3290
65	2½	FIA-SS 65 D STR Filter Housing 52 bar	148H3291

FIA-SS Angle flow

Size		Type designation	Code number
mm	in.		
15	½	FIA-SS 15 D ANG Filter Housing 52 bar	148H3221
20	¾	FIA-SS 20 D ANG Filter Housing 52 bar	148H3222
25	1	FIA-SS 25 D ANG Filter Housing 52 bar	148H3223
32	1¼	FIA-SS 32 D ANG Filter Housing 52 bar	148H3224
40	1½	FIA-SS 40 D ANG Filter Housing 52 bar	148H3225
50	2	FIA-SS 50 D ANG Filter Housing 52 bar	148H3283
65	2½	FIA-SS 65 D ANG Filter Housing 52 bar	148H3284

Danfoss has developed a range of accessories which improve the utility of the filters i.e. a magnetic insert may catch metal particles, and a filterbag, which is very useful in the start-up phase. Danfoss offers two different types of filter elements, plain and pleated. The pleated filter elements have a much bigger dirt capacity due to a much larger filter surface.

Accessories

Part	Accessory for	Code number
Magnet insert	FIA 65-100	2464+596
	FIA 125-200	2464+597
Part	Accessory for	Code number
Filter element µ150 with removable element µ50 for the first start up	FIA 15-20	148H3301
	FIA 25-40	148H3302
Part	Accessory for	Code number
Purge valve complete, blind nut and gasket	FIA 50 - 200	2412+634

Part	Accessory for	Code number
Filter bag	FIA 50	148H3150
	FIA 65	148H3151
	FIA 80	148H3152
	FIA 100	148H3153
	FIA 125	148H3154
	FIA 150	148H3155
	FIA 200	148H3156

Danfoss has a complete range of filters with ANSI connection as well as a wide range of filter elements, pleated filter elements and accessories such as magnetic inserts and filter bags for start up. For further information; please see the technical leaflet.
D = Butt-weld DIN, A = Butt-weld ANSI, ANG = Angle-way, STR = Straight-way



LLG - liquid level glasses

LLG are liquid level glasses made of ductile steel which meets the strictest requirements on industrial and marine refrigeration installations

LLG has sufficient flow areas to secure the highest possible degree of synchronous operation, and have a specially hardened reflection glass for quick reading. The LLG are delivered with stop valves, which ensures easy insulation on site as well as easy inspection and service, if any.



Advantages and features

- All LLG liquid level glasses are equipped as standard with a built-in safety system (non return device). If a glass is damaged, the pressure of the refrigerant will activate the safety system and refrigerant loss will be limited to an absolute minimum.
 - Refrigerants
Applicable to all common non flammable refrigerants including R717 and non corrosive gases/liquids dependent on sealing material compatibility.
 - Temperature range
-10/+100°C or -50/+30°C
 - Maximum operating pressure: 25 bar g
Equipped with boron-silicate glass, hardened by an accurately controlled heat treatment process.
 - Classification: To get an updated list of certification on the products please contact your local Danfoss Sales Company.
 - The range of liquid level glasses is based on 3 basic liquid level glasses: LLG 185, LLG 335 and LLG 740. The other standard lengths are combined by using variations of basic glass lengths.
 - The liquid level glasses are offered in 4 different versions:
 - with welding nipples (LLG).
 - with stop valves equipped with caps (LLG S).
 - with sight adapter in acrylic glass ready for insulation on site (LLG F).
 - with stop valves and sight adapter in acrylic glass ready for insulation on site (LLG SF).
- NOTE:** The LLG liquid level glass can only be placed in CE approved applications with the stop valves in front i.e. LLG S or LLG SF.

Technical data and code numbers

Technical data

	LLG
Refrigerants	The liquid level glasses are applicable to all common non flammable refrigerants including R717 and non corrosive gases/liquids. Flammable hydrocarbons are not recommended.
Temperatur range	LLG S: -10/+100°C LLG SF: -50/+30°C
Pressure range Max. operating pressure	25 bar g
Pressure range Strength test	50 bar g
Pressure range Leakage test	at 25 bar g

Please see the technical leaflet for further details.

Code numbers

Liquid level glasses - LLG S *With safety system and stop valves (SNV-ST)*

Length		Type	Code no.
mm	in.		
185	7¼	LLG 185 S	2512+056
335	13¼	LLG 335 S	2512+057
590	23¼	LLG 590 S	2512+058
740	29¼	LLG 740 S	2512+059
995	39¼	LLG 995 S	2512+060
1145	45	LLG 1145 S	2512+061
1550	61	LLG 1550 S	2512+062

Liquid level glasses for insulating - LLG SF *With safety system, stop valves (SNV-ST) and sight adapter*

Length		Type	Code no.
mm	in.		
185	7¼	LLG 185 SF	2512+066
335	13¼	LLG 335 SF	2512+067
590	23¼	LLG 590 SF	2512+068
740	29¼	LLG 740 SF	2512+069
995	39¼	LLG 995 SF	2512+070
1145	45	LLG 1145 SF	2512+071
1550	61	LLG 1550 SF	2512+072

Important!

Where products need to be certified according to specific certification societies or where higher pressures are required, the relevant information should be included at the time of order.

GD - Gas Detectors

Danfoss Gas Detectors, type GD are a range of products designed to meet all industrial refrigeration and air conditioning application requirements. GD detects a wide range of commonly used refrigerants including Ammonia, Carbon Dioxide, Halo-Carbons and Hydro-Carbons.



Advantages and features

- GD is specifically developed for refrigeration applications
- Interchangeable precalibrated sensors
- Optional models: LCD display, IP 65 enclosure, EExd (Explosion Protected)
- Can operate as stand alone product
- Linear analog outputs, current (mA) / volt (V) proportional to the gas concentration
- Two digital outputs. Low Level and High Level Alarm
- Adjustable setting for alarm levels and output contacts with optional NO or NC switches
- Manual or automatic alarm reset optional
- Alarm levels can be set locally.
- GD can be connected directly to a Danfoss monitoring unit system
- Available with a range of different sensor technologies to monitor industrial refrigeration gases:
 - Electro-Chemical
 - Semi-Conductor
 - Catalytic
 - Infra-Red

Technical data and code numbers

Technical data

Refrigerants	Ammonia (R 717) Type GDA: 0-100 ppm, 0-300 ppm, 0-1,000 ppm, 0-10,000 ppm, 0-30,000 ppm
	Carbon Dioxide (R 744) Type GDC: 0-10,000 ppm, 0-20,000 ppm, 0-30,000 ppm
	Halo-Carbon - HCFC (R 22, R 123) Type GDHC: 0-1,000 ppm
	HFC (R 404A, R 410A, R 134A, R 407C, R 507) Type GDHF: 0-1,000 ppm
	Hydro-carbon - Propane (R 290, R 600, R 600A, R 1270) Type GDH: 0-5,000 ppm
Versions / temperature range	Standard, LCD display, IP 65 and EExd: -20°C/+50°C
	Low temperature model: -40°C/+50°C
Cable connection	1 gland for 6-13 mm cable (0.2"-0.5") 1 Ø 20 mm (0.8") hole with blanking plug. 1 extra gland can be fitted (only Standard, LCD display and EExd).
Approvals	CE: EN55011: 1998, EN61326: 1996 Following the provisions of 89/336/EEC, EMC directives and, Cenelec EN61010-2 : 2001 Following the provisions of 73/23/EEC, Low Voltage directive (LVD) ATEX for EExd model: Directive 94/9/EC Group 2, Category2, G and D, Zones 1 and 2.

Code numbers

Type of gas	All models		Standard	With LCD display	EExd	IP 56 Low Temp.	EExd Low Temp.	IP 66 with remote IP 65 sensor	IP 66 with remote IP 65 EExd sensor	IP 56
	Danfoss Type *	Range [PPM]								
Code No.										
Ammonia - NH₃										
R 717	GDA EC 100	0-100	148H5000	148H5001	148H5003	148H5005	148H5006			148H5009
	GDA EC 300	0-300			148H5063					
	GDA EC 1000	0-1,000	148H5010	148H5011	148H5013	148H5015	148H5016			148H5019
	GDA EC 1000	0-1,000	148H5050	148H5051	148H5053	148H5055				148H5059
	GDA SC 1000	0-1,000	148H5040							148H5049
	GDA SC 10000	0-10,000	148H5020	148H5021	148H5023	148H5025	148H5026	148H5027	148H5028	148H5029
	GDA CT 30000	0-30,000	148H5030	148H5031	148H5033	148H5035				148H6039
Carbon Dioxide - CO₂										
R 744	GDC IR 10000	0-10,000	148H5070	148H5071	148H5073	148H5075				148H5072
	GDC IR 20000	0-20,000				148H5085				148H5092
	GDC IR 40000	0-40,000								148H5092
Halo-Carbon										
HCFC (R 22, R 123)	GDHC SC 1000	0-1,000	148H5100	148H5101		148H5105		148H5107		148H5109
HFC (R 404A, R 410A, R 134A, R 407C, R 507)	GDHF SC 1000	0-1,000	148H5110	148H5111		148H5115		148H5117		148H5119
HFC (R 134a)	GDHF-R3 SC 1000	0-1,000	148H5120	148H5121		148H5125		148H5127		148H5129
Hydro-carbon										
(R 290(Propane), R 600, R 600A, R 1270)	GDH CT 5000	0-5,000	148H5160	148H5161	148H5193					
Various gases										
Various gases	GDCM SC 500	0-5,000	148H5180							

EC = Electro-chemical
 SC = Semi-chemical
 CT = Catalytic
 IR = Infrared

Please consult the technical leaflet for more versions and for more information.



EKC 315A - Refrigeration control

The controller and valve can be used where there are requirements to accurate control of superheat and temperature in connection with refrigeration. E.g.:

- Cold store (air coolers)
- Processing plant (water chillers)
- A/C plant



Functions

- Regulation of superheat
- Temperature control
- MOP function
- ON/OFF input for start/stop of regulation
- Input signal that can displace the superheat reference or the temperature reference
- Alarm if the set alarm limits are exceeded
- Relay output for solenoid valve
- PID regulation
- Output signal following the temperature showing in the display

Advantages

- The evaporator is charged optimally – even when there are great variations of load and suction pressure
- Energy savings – the adaptive regulation of the refrigerant injection ensures optimum utilisation of the evaporator and hence a high suction pressure
- Exact temperature control – the combination of adaptive evaporator and temperature control ensures great temperature accuracy for the media
- The superheating is regulated to the lowest possible value at the same time as the media temperature is controlled by the thermostat function

Technical data and ordering

Technical data

Supply voltage	24 V a.c. +/-15% 50/60 Hz, (80 VA) (the supply voltage is galvanically separated from the input and output signals)	
Power consumption	Controller AKV coil	5 VA 55 VA
Input signal	Current signal	4-20 mA or 0-20 mA
	Pressure transmitter	4-20 mA from AKS 33
	Digital input from external contact function	
Sensor input	2 pcs. Pt 1000 ohm	
Output signal	Current signal	4-20 mA or 0-20 mA
	Load	Max. 200 ohm
Relay output	1 pcs. SPST	AC-1: 4 A (ohmic)
Alarm relay	1 pcs. SPST	AC-15: 3 A (inductive)
ICAD	ICAD mounted on ICM	Current signal 4-20 mA or 0-20 mA
Data communication	Possible to connect a data communication module	
Environments	-10 to 55°C, during operations	
	-40 to +70°C, during transport	
	20 - 80% Rh, not condensed	
	No shock influence/vibrations	
Enclosure	IP 20	
Weight	300 g	
Mounting	DIN rail	
Display	LED, 3 digits	
Terminals	max. 2.5 mm ² multicore	
Approvals	EU Low Voltage Directive and EMC demands re CE-marking complied with. LVD-tested acc. to EN 60730-1 and EN 60730-2-9 EMC-tested acc. to EN50081-1 and EN 50082-2	

The installation of data communications must comply with the requirements described in literature sheet no. RC8AC

Ordering

Type	Description	Code no.
EKC 315A	Superheat controller	084B7086
EKC 315A	Superheat controller, AKS 32R	084B7085
EKC 315A	I-pack of 084B7085	084B7128

Accessories

EKA 173	FTT 10 LON	084B7092
EKA 174	Data communication module (accessories), (RS 485 module) with galvanic separation	084B7124
EKA 175	RS485 LON	084B7093
AKA 211	Cable filter *	084B2238
AKS 11	Pt 1000 Sensor	084N0003
AKS 33	Pressure transmitter -1/12 bar, 0.3%	060G2049
AKS 3000	Pressure transmitter -1/12 bar, 1%	060G1323

*When cable lengths exceed 5 m, max. cable length with filter: 50 m

Additional information!
Manual: RS8CS



EKC 202 - Refrigeration controller

The series of EKC 202 controllers can be used for a wide range of different refrigeration applications – from control of air temperatures and defrost to more advanced applications, including control of light and fans.



Functions

Thermostat

- ON/OFF heating or cooling thermostat
- Sensors: Danfoss Pt1000, PTC1000 or NTC5000
- Day / night control
- Thermostat band
- Alarm thermostat with delay

Defrost

- Electrical, natural or hot gas defrost
- Start via DI input, time interval or schedule (RTC)
- Defrost on demand
- Stop on time or temperature
- Coordinated defrost

Compressor

- Anti cycle timers for optimum protection
- High-effect 16A relays for connection of compressors without use of intermediate relays

DI input

- Multi purpose DI input for defrost start, door function, night setback, main switch, appliance cleaning, general alarm, defrost coordination and thermostat band.

Fan

- Fan delay during defrost
- Fan stop when compressor cuts out
- Fan stop at high S5 temperature

Light control

- Light control of day/night, door, or via network

Advantages

- **Integrated refrigeration-technical functions**
- **Defrost on demand in 1:1 systems**
- **Buttons and seal imbedded in the front**
- **IP 65 density from the front panel**
- **Digital input for either:**
 - Door contact function with alarm
 - Defrost start
 - Start/stop of regulation
 - Night operation
 - Change-over between two temperature reference
 - Case cleaning function
- **Instant programming via programming key**
- **HACCP**
Factory calibration that will guarantee a better measuring accuracy than stated in the standard EN 441-13 without subsequent calibration (Pt 1000 ohm sensor)

Technical data and ordering

Technical data

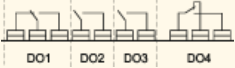
Supply voltage	230 V a.c. +10/-15 %. 1.5 VA		
Sensors	Pt 1000 or PTC (1000 ohm/25°C) or NTC-M2020 (5000 ohm/25°C)		
Accuracy	Measuring range	-60 to +99°C	
	Controller	±1 K below -35°C ±0,5 K between -35 to +25°C ±1 K above +25°C	
	Pt 1000 sensor	±0.3 K at 0°C ±0.005 K per grad	
Display	LED, 3 digits		
Digital inputs	Signal from contact functions Requirements to contacts: Gold plating Cable length must be max. 15 m Use auxiliary relays when the cable is longer		
Electrical connection cable	Max.1,5 mm ² multi-core cable on supply and relays. Power current terminals are mounted on the circuit board. Max. 1 mm ² on sensors - and DI inputs. Low current terminals are with plugs		
 Relays*		CE (250 V a.c.)	UL *** (240 V a.c.)
	DO1. Refrigeration	10 (6) A	10 A Resistive 5FLA, 30LRA
	DO2. Defrost	10 (6) A	10 A Resistive 5FLA, 30LRA
	DO3. Fan	6 (3) A	6 A Resistive 3FLA, 18LRA 131 VA Pilot duty
	DO4. Alarm or light	4 (1) A Min. 100 mA**	4 A Resistive 131 VA Pilot duty
Environments	0 to +55°C, During operations -40 to +70°C, During transport		
	20 - 80% Rh, not condensed		
	No shock influence/vibrations		
Enclosure	IP 65 from front. Buttons and packing are imbedded in the front.		
Escapement reserve for the clock	4 hours		
Approvals	EU Low Voltage Directive and EMC demands re CE-marking complied with LVD tested acc. EN 60730-1 og EN 60730-2-9, A1, A2 EMC tested acc. EN50082-1 og EN 60730-2-9, A2		

* DO1 and DO2 are 16 A relays. DO3 and DO4 are 8 A relays. Max. load must be kept.

** Gold plating ensures make function with small contact loads

*** UL-approval based on 30000 couplings

Ordering

Type	Description	Code No.
EKC 202A	Refrigeration controller	084B8521
EKC 202B	Refrigeration controller with fan function	084B8522
EKC 202C	Refrigeration controller for electric defrost	084B8523

Accessories

EKA 178A	Data communication module MOD bus	084B8564
EKA 179A	RS485 LON	084B8565
EKA 181A	Battery & Buzzer	084B8566
EKA 181C	Battery module that will protect the clock in case of lengthy power failure	084B8577
EKA 182A	Copy key EKC - EKC	084B8567
AKS 12	Pt 1000 Sensor	084N0036
EKS 111	PTC 1000 Sensor	084N1178
EKS 211	NTC 5000 Sensor	084N1220

Additional information!
Manual: RS8DZ



AK-CC 550 - Controller for appliance control

AK-CC 550 is a complete refrigeration appliance control with great flexibility to adapt to all types of refrigeration appliances and cold storage rooms.



Functions

- Day/night thermostat with ON/OFF or modulating principle
- Product sensor S6 with separate alarm limits
- Switch between thermostat settings via digital input
- Adaptive control of superheat
- Adaptive defrosting based on evaporator performance
- Start of defrost via schedule, digital input or network
- Natural, electric or hot gas defrost
- Stop of defrost on time and/or temperature
- Coordination of defrosting among several controls
- Pulsing of fans when thermostat is satisfied
- Case cleaning function for documentation of HACCP procedure
- Rail heat control via day/night load or dew point
- Door function
- Control of two compressors
- Control of night blinds
- Light control
- Heat thermostat
- Factory calibration that will ensure a better measuring accuracy than stated in the standard EN 441-13 without subsequent calibration (Pt 1000 ohm sensor)
- Integrated MODBUS communication with the option of mounting a LonWorks or Ethernet communication card

Advantages

- Energy optimisation of the whole refrigeration appliance
- One controller for several different refrigeration appliances
- Integrated display at the front of the controller
- Quick set-up with predefined settings
- Built-in data communication
- Built-in clock function with power reserve

Technical data and ordering

Technical data

Supply voltage	230 V a.c. +10/-15%, 5 VA	
Sensor S111, (S1)	Pt 1000	
Sensor S3, S4, S5, S6	Pt 1000 PTC 1000 ohm/1115°C (All 4 must be of the same type)	
Accuracy	Measuring range	-60 to +120°C
	Controller	±1 K below -35°C ±0.5 K between -35 to +1115°C ±1 K above +1115°C
	Pt 1000 sensor	±0.3 K at 0°C ±0.005 K per grad
Measuring of Pe	Pressure transmitter	AKS 3111R
Display	LED, 3-digits	
External display	EKA 163B or 164B. (any EKA 163A or 164A)	
Digital inputs DI1, DI111	Signal from contact functions Requirements to contacts: Gold plating Cable length must be max. 15 m Use auxiliary relays when the cable is longer	
Digital input DI3	11130 V a.c.	
Electrical connection cable	Max. 1.5 mm ¹¹¹ multi-core cable	
Solid state output	DO1 (for AKV coil)	Max. 11140 V a.c. , Min. 1118 V a.c. Max. 0,5 A Leak < 1 mA Max. 1 pcs. AKV
		CE (250 V a.c.)
Relays*	DO3, DO4	4 (3) A
	DO2, DO5, DO6	4 (3) A
Environments	0 to +55°C, During operations -40 to +70°C, During transport	
	20 - 80% Rh, not condensed	
	No shock influence/vibrations	
Density	IP 20	
Mounting	DIN rail or on wall	
Weight	0.4 kg	
Data communication	Fixed	MODBUS
	Extension options	LON RS485
		TCP/IP
		MODBUS
The controller cannot be hooked up with a monitoring unit type m2.		
Power reserve for the clock	4 hours	
Approvals	EU Low Voltage Directive and EMC demands re CE-marking complied with. LVD-tested acc. to EN 60730-1 and EN 60730-2-9 EMC-tested acc. to EN 50081-1 and EN 50082-2	

*) DO3 and DO4 are 16 A relays. DO111, DO5 and DO6 are 8 A relays. Max. load must be observed.

Ordering

Type	Description	Code no.
AK-CC 550	Case controller with MODBU data communication Sensor connections are with screw terminals	084B8020
	Case controller with MODBU data communication Sensor connections are with plug connections	084B8021
EKA 175	Data communication module LON RS 485	084B8579
EKA 177	Data communication module Ethernet	084B8581
EKA 178B	Data communication module MODBUS	084B8571
EKA 163B	External display with plug fo direct connection	084B8574
EKA 164B	External display operation buttons and plug for direct connection	084B8575
EKA 163A	External display with screw terminals	084B8562
EKA 164A	External display with operation buttons and screw terminals	084B8563
EKA 17111	RTC-module	084B7069

Additional information!
Manual: RS8EN



EKC 102 - Temperature controller

EKC 102 controllers for panel mounting are used for temperature and defrost control via pump-down or start/stop of compressor.



Functions

Thermostat

- ON/OFF thermostat
- Sensors: Danfoss Pt1000, PTC1000 or NTC5000
- Calibration of sensors
- Day/night control
- Alarm thermostat with delays

Defrost

- Electrical or natural defrost
- Start via DI input, time interval or display
- Defrost on demand
- Stop on time or temperature

Compressor

- Anti cycle timers for optimum compressor protection
- High-effect 16A relays for connection of compressors without use of intermediate relay
- Control of 2 compressors (version 102B)

Multipurpose DI input

- Multipurpose DI input for defrost start, day/night control, dooralarm or main switch

Other functions

- The S5 sensor can be used for monitoring of condenser temperature or as product sensor (version 102B+102D)
- Door function with alarm monitoring
- Manual control of outputs
- Delay of outputs at power up

Display & Programming

- High-efficient LED display with icons for indication of operational status. Parameter settings/readouts and alarm conditions can be read on the display.
- "Copy key" programming key with room for 25 different controller setups

Fan (102D only)

- Fan delay during defrost
- Fan stop when compressor cuts out
- Fan stop at high S5 temperature

Advantages

- Integrated refrigeration-technical functions
- Defrost on demand in 1:1 systems
- Buttons and seal imbedded in the front
- IP 65 density from the front panel
- Can control two compressors
- Digital input for either:
 - Door alarm
 - Defrost start
 - Start/stop of regulation
 - Night operation
 - Change-over between two temperature reference
 - Case cleaning function
- Instant programming via programming key
- HACCP
 - Factory calibration that will guarantee a better measuring accuracy than stated in the standard EN 441-13 without subsequent calibration (Pt 1000 ohm sensor)

Technical data and ordering

Technical data

Supply voltage	230 V a.c.(115 V) +10/-15 %. 1.5 VA		
Sensors	Pt 1000 or PTC (1000 ohm/25°C) or NTC-M2020 (5000 ohm/25°C)		
Accuracy	Measuring range	-60 to +99°C	
	Controller	±1 K below -35°C ±0.5 K between -35 to +25°C ±1 K above +25°C	
	Pt 1000 sensor	±0.3 K at 0°C ±0.005 K per grad	
Display	LED, 3 digits		
Digital inputs	Signal from contact functions Requirements to contacts: Gold plating Cable length must be max. 15 m Use auxiliary relays when the cable is longer		
Electrical connection cable	Max.1.5 mm ² multi-core cable on supply and relays. Max. 1 mm ² on sensors - and DI inputs. Terminals are mounted on the circuit board		
Relays*		CE (250 V a.c.)	UL ** (240 V a.c.)
	DO1. Refrigeration	10 (6) A	10 A Resistive 5FLA, 30LRA
	DO2. Alarm/ Defrost/ Refrigeration	10 (6) A	10 A Resistive 5FLA, 30LRA
	DO3. Fan	6 (3) A	6 A Resistive 3FLA, 18LRA 131 VA Pilot duty
Environments	0 to +55°C, During operations -40 to +70°C, During transport		
	20 - 80% Rh, not condensed		
	No shock influence/vibrations		
Enclosure	IP 65 from front. Buttons and packing are imbedded in the front.		
Approvals	EU Low Voltage Directive and EMC demands re CE-marking complied with LVD tested acc. EN 60730-1 og EN 60730-2-9, A1, A2 EMC tested acc. EN50082-1 og EN 60730-2-9, A2		

* DO1 and DO2 are 16 A relays. DO3 is a 8 A relay. Max. load must be kept.

** UL-approval based on 30000 couplings

Ordering

Type	Description	Supply	Code No.
EKC 102A	Temperature controller	230 V a.c.	084B8500
		115 V a.c.	084B8503
EKC 102B	Temperature controller with alarm function	230 V a.c.	084B8501
		115 V a.c.	084B8504
EKC 102C	Temperature controller for electric defrost	230 V a.c.	084B8502
		115 V a.c.	084B8505
EKC 102D	Controller for refrigeration with fan function	230 V a.c.	084B8506
		115 V a.c.	084B8507

Accessories

EKA 179A	RS485 LON	084B8565
EKA 181A	Battery & Buzzer	084B8566
EKA 182A	Copy key EKC - EKC	084B8567
AKS 12	Pt 1000 Sensor	084N0036
EKS 111	PTC 1000 Sensor	084N1178
EKS 211	NTC 5000 Sensor	084N1220

Additional information!

Manual: RS8DY



AK-CC 210 - Universal refrigeration controller

The controller is used for evaporator control refrigeration appliances in supermarkets. With many predefined applications one unit will offer you many options. Flexibility has been planned both for new installations and for service in the refrigeration trade.



Functions

Thermostat

- ON/OFF heating or cooling thermostat
- Sensors: Danfoss Pt1000, PTC1000 or NTC5000
- Day / night control
- Thermostat band
- Alarm thermostat with delay

Defrost

- Electrical, natural or hot gas defrost
- Start via DI input, time interval or schedule (RTC)
- Defrost on demand
- Stop on time or temperature
- Coordinated defrost

Compressor

- Anti cycle timers for optimum protection
- High-effect 16A relays for connection of compressors without use of intermediate relays

DI input

- Multi purpose DI input for defrost start, door function, night setback, main switch, appliance cleaning, general alarm, defrost coordination and thermostat band.

Fan

- Fan delay during defrost
- Fan stop when compressor cuts out
- Fan stop at high S5 temperature

Light control

- Light control of day/night, door, or via network
- Other functions
- S5 sensor can be used for monitoring of condenser temperature or as product sensor
- Door function with alarm monitoring
- Manual control of outputs
- Case cleaning function

Supplementary options

- RS 485 network card for connection to network
- Battery back-up card for real time clock
- "Copy key" programming key

Advantages

- Many applications in the same unit
- The controller has integrated refrigeration-technical functions, so that it can replace a whole collection of thermostats and timers
- Buttons and seal imbedded in the front
- Can control two compressors
- Easy to remount data communication
- Quick setup
- Two temperature references
- Digital inputs for various functions
- Clock function with backup
- HACCP (Hazard Analysis and Critical Control Points)
 - Temperature monitoring and registration of period with too high temperature
 - Factory calibration that will guarantee a better measuring accuracy than stated in the standard EN 441-13 without subsequent calibration (Pt 1000 ohm sensor)

Technical data and ordering

Technical data

Supply voltage	230 V a.c. +10/-15 %. 2.5 VA		
Sensors 3 pcs off either	Pt 1000 or PTC (1000 ohm / 25°C) or NTC-M2020 (5000 ohm / 25°C)		
Accuracy	Measuring range	-60 to +99°C	
	Controller	±1 K below -35°C ±0.5 K between -35 to +25°C ±1 K above +25°C	
	Pt 1000 sensor	±0.3 K at 0°C ±0.005 K per grad	
Display	LED, 3-digits		
External display	EKA 163A		
Digital inputs	Signal from contact functions Requirements to contacts: Gold plating Cable length must be max. 15 m Use auxiliary relays when the cable is longer		
Electrical connection cable	Max.1,5 mm ² multi-core cable		
Relays*		CE (250 V a.c.)	UL *** (240 V a.c.)
	DO1. Refrigeration	10 (6) A	10 A Resistive 5FLA, 30LRA
	DO2. Defrost	10 (6) A	10 A Resistive 5FLA, 30LRA
	DO3. Fan	6 (3) A	6 A Resistive 3FLA, 18LRA 131 VA Pilot duty
	DO4. Alarm	4 (1) A Min. 100 mA**	4 A Resistive 131 VA Pilot duty
Environments	0 to +55°C, During operations -40 to +70°C, During transport		
	20 - 80% Rh, not condensed		
	No shock influence / vibrations		
Density	IP 65 from front. Buttons and packing are embedded in the front.		
Escapement reserve for the clock	4 hours		
Approvals	EU Low Voltage Directive and EMC demands re CE-marking complied with LVD tested acc. EN 60730-1 og EN 60730-2-9, A1, A2 EMC tested acc. EN50082-1 og EN 60730-2-9, A2		

* DO1 and DO2 are 16 A relays. DO3 and DO4 are 8 A relays. Max. load must be kept.

** Gold plating ensures make function with small contact loads

*** UL-approval based on 30000 couplings

Ordering

Type	Description	Code No.
AK-CC 210	Refrigeration controller without data communication but prepared for LON RS 485 module	084B8520

Accessories

EKA 163A	External display for AK-CC 210	084B8562
EKA 178A	Data communication module MOD bus	084B8564
EKA 179A	RS485 LON	084B8565
EKA 181A	Battery & Buzzer	084B8566
EKA 181C	Battery module that will protect the clock in case of lengthy power failure	084B8577
EKA 182A	Copy key EKC - EKC	084B8567
AKS 12	Pt 1000 Sensor	084N0036
EKS 111	PTC 1000 Sensor	084N1178
EKS 211	NTC 5000 Sensor	084N1220

Additional information!
Manual: RS8DZ



AK-SM 350 - System Manager

The unit is a combined data collection unit and monitoring unit for smaller refrigeration installations.

- Corner shops
- Smaller supermarkets
- Restaurants
- Food manufacturers



Functions

The monitoring unit can monitor up to 65 measurements.

They can originate from:

- up to 16 direct connections from sensors or switch functions
- signals from separate refrigeration controllers, EKC and AK types, via data communication
- signals from connections on the expansion module m2+ and from gas detectors. These readings are also transferred via data communication.
- Pulse counting function for energy display
- All defined points can be recorded and saved with the set time intervals.
- The values can be viewed on the display and retrieved by connecting a printer or connecting a PC or modem.

Advantages

Compact unit for registering temperatures

- Collects temperature data to present to authorities
- Alarm function
 - Local alarm or via modem/IP
 - Alarm at deviations in temperature
 - Alarms when doors to cold storage rooms and freezer rooms are open
- Text describing the measuring area can be added to the measuring points

Technical data and ordering

Technical data

Supply	115 V/230 V +10/-15%, 50/60 Hz, 10 VA	
Connection	PT 1000 ohm at 0°C or PTC 1000 ohm at 25°C or NTC 5000 ohm at 25°C or Termistor (-80 to 0, -40 to 40 or 0 to 100°C) Digital On/Off signal or Standard 0 - 10 V /4 - 20 mA signal	
Display	Graphic LCD, 240 x 64	
Direct measuring points	16	
Total number of points	65	
Measuring range, general	-60 to +50°C	
Measuring accuracy at Pt 1000	Resolution 0.1 K Accuracy: +/- 0.5 K	
Measuring interval	15, 30, 60, 120 or 240 minutes	
Data capacity	55 log points, every 15 min. for 1 year	
Battery backup	Button cell for clock function	
Power supply for e.g. pressure transmitter	5 V max. 50 mA 12 V max. 50 mA	
Pulse counter inputs for output reading	Acc. to DIN 43864. (Only for inputs 1 and 2)	
Printer connection	HP PCL-3, Parallel	
Modem connection	RJ 45	
TCP/IP connection	RJ 45	
PC connection	RJ 45	
Data communication	RS232, RS 485 (LON), RS 485 (MOD-bus), RS 485 (TP) (TP= Third Party)	
Relays	Quantity	2
	Max. load	24 V a.c. or 230 V a.c. I _{max} (AC-1) = 5 A I _{max} (AC-15) = 3 A
Enclosure	IP 20	
Ambient environmen	0 to 50°C, during operation -20 to +70°C, during transport 20-80% RH, Non-condensed No shock loads/vibrations	
Approvals	EN 60730-1 and EN 60730-2-9 EN 50081-1 and EN 50082-1	
Weight	1.6 Kg	

Additional information!

Manual: RS8EF

Ordering

Type	Measuring points	Description	Language	Code No.
AK-SM 350	16	With inputs for PT 1000 ohm & PTC 1000 ohm	English, German, French, dutch, Italian	080Z8500
			English (UK), Spanish, Portuguese, English (US)	080Z8502
			English, Danish, Swedish, Finnish	080Z8503
m2+	16			080Z8005

Accessories

Printer cable 3 m (parallel)		080Z8401
Cable for PC (see also AK-ST 500 literature)	RJ 45 - Com port	080Z0262

Important: Installation of data communication cables and repeaters must comply with the requirements contained in the document:

Data communication between ADAP-KOOL® Refrigeration system controls.

Number = RC8AC.



EKC 361 - Media temperature control

The controller and valve can be used where there are stringent requirements to accurate temperature control in connection with refrigeration. E.g.:

- Cold room for fruits and food products
- Refrigerating systems
- Work premises in the food industry
- Process cooling of liquids



Functions

- Modulating temperature control
 - Digital ON/OFF input for start/stop of regulation ICS/PM or forced closing of ICM
 - Alarm if the set alarm limits are exceeded
 - Relay output for fan
 - Relay output for solenoid valves
 - Analog input signal that can displace the temperature reference
 - Analog Output signal corresponding to selecting temperature as running display value.
- Please observe : Not possible if ICM is selected as valve

Advantages

- The temperature is kept within an accuracy of $\pm 0.25^{\circ}\text{C}$ or better in normal operation
- The evaporator's temperature is kept as high as possible, so that the air humidity is kept high to avoid waste
- A transient phenomenon can be controlled with the adaptive function. Select either:
 - Fast build-up where underswings are allowed
 - Not quite so fast build-up where underswings are less pronounced
 - Build-up without underswings
- PID regulation
- p_0 limitation

Technical data and ordering

Technical data

Supply voltage	24 V a.c. +/-15% 50/60 Hz, 80 VA (the supply voltage is galvanically separated from the input and output signals)	
Power consumption	Controller	5 VA
	Actuator	75 VA
Input signal	Current signal	4-20 mA or 0-20 mA
	Digital input from external contact function	
Sensor input	2 pcs. Pt 1000 ohm	
Output signal	Current signal	4-20 mA or 0-20 mA Max. load: 200 ohm
Relay output	2 pcs. SPST	a.c.-1: 4 A (ohmic)
Alarm relay	1 pcs. SPST	a.c.-15: 3 A (inductive)
Actuator	Input	Temperature signal from sensor in the actuator
	Output	Pulsating 24 V a.c. to actuator
Data communication	Possible to connect a data communication module	
Ambient temperature	During operation	-10 - 55°C
	During transport	-40 - 70°C
Enclosure	IP 20	
Weight	300 g	
Mounting	DIN rail	
Display	LED, 3 digits	
Terminals	max. 2.5 mm ² multicore	
Approvals	EU Low Voltage Directive and EMC demands re CE-marking complied with. LVD-tested acc. to EN 60730-1 and EN 60730-2-9 EMC-tested acc. to EN50081-1 and EN 50082-2	

Ordering

Type	Description	Code No.
EKC 361	Evaporating pressure controller	084B7060

Accessories

EKA 173	FTT 10 LON	084B7092
EKA 174	Data communication module (accessories), (RS 485 module) with galvanic separation	084B7124
EKA 175	RS485 LON	084B7093
AKS 21M	Pt 1000 Sensor	084N2003
AKA 211	Cable filter *	084B2238

* When cable lengths between controller and valve exceed 5 m, max. cable length with filter: 50 m

The installation of data communications must comply with the requirements described in literature sheet no. RC8AC



EKC 366 - Controller Interface

The controller is used for regulating a valve in a refrigerating system - for example in connection with:

- Long-term storage of fruits and vegetables
- Refrigerating plant
- Brewery systems
- Processing plant



Functions

- The valve constantly receives feedback of the pressure in the evaporator. Whatever the variations in the suction pressure from the compressor, this feedback will produce the result that the evaporating pressure is kept constant.
- In conjunction with the controller, an electronic constant pressure valve is thus obtained.
- Inserted between the controller and the actuator is a so-called inner regulating loop. This loop will – via an NTC resistance – constantly control the temperature in the actuator.
- In an application where a PLC or similar device is used for regulating a media temperature, the regulating system will in this way be supplied with an outer regulating loop – which will result in great regulating accuracy.

Advantages

The controller has been specially designed for the following functions:

- **Maintenance of a constant evaporating pressure**
A temperature sensor in the valve's actuator will regulate its temperature. This temperature is an indication of the pressure in the valve, and the interface module will keep this temperature constant.
- **The media temperature is regulated by a PLC or similar device.**
Here the interface module receives a variable signal from the PLC and will subsequently regulate the valve, so that the refrigeration will be as accurate as possible.

Technical data and ordering

Technical data

Supply voltage	24 V a.c. +/-15% 50/60 Hz, 80 VA (the supply voltage is galvanically separated from the input and output signals)	
Power consumption	Controller Valve	5 VA 75 VA
Input signal	4-20 mA, 0-20 mA, 0-10V d.c. or 2-10 V d.c.	
Actuator	Input	Temperature signal from sensor in actuator
	Output	Pulsating 24 V a.c. to actuator
Data communication	Possible to connect a data communication module	
Ambient temperature	During operation	-10 - 55°C
	During transport	-40 - 70°C
Enclosure	IP 20	
Weight	300 g	
Mounting	DIN rail	
Display	LED, 3 digits	
Terminals	max. 2.5 mm ² multicore	
Approvals	EU Low Voltage Directive and EMC demands re CE-marking complied with. LVD-tested acc. to EN 60730-1 and EN 60730-2-9 EMC-tested acc. to EN 50081-1 and EN 50082-2	

Ordering

Type	Function	Code No.
EKC 366	Interface module	084B7076

Accessories

EKA 173	Data communication module (accessories), (FTT 10 module)	084B7092
EKA 174	Data communication module (accessories), (RS 485 module) with galvanic separation	084B7124

Valves: Kindly refer to catalogue RKOYG



XGE/RGE: Condenser fan speed controls

Fan speed control is becoming increasingly widespread in different refrigeration and air conditioning units, with the benefits of reduced noise and stable condensing pressures under different climatic conditions. The XGE range is very compact and offers the ideal solution for reliable fan control for most units where small fans are used. For medium to large sized fans (single and three phase) the RGE range offers a simple and efficient fan speed control solution.

Features

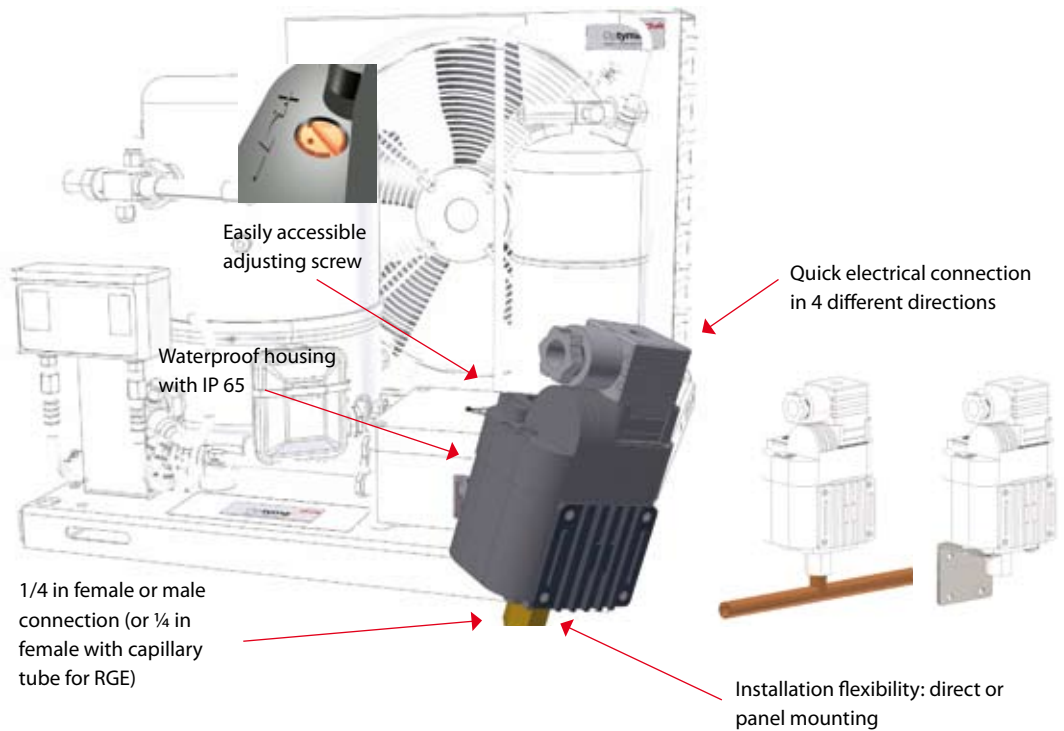

Applications	Advantages	Facts
<ul style="list-style-type: none"> • Freezing and refrigeration condensing units • Packaged air conditioners and chillers 	<ul style="list-style-type: none"> • Simple to install and easy setting • "All in one": senses pressure and controls fan speed • Reliable sensing mechanism • XGE: <ul style="list-style-type: none"> - Compact & light weight (length: 112mm - diameter: 66mm - weight: 180g) - Can be directly mounted onto the refrigeration line or fixed onto a simple bracket (accessory) and screwed to a panel - Easily accessible adjusting screw on the top surface - Easy wiring and electrical connection - Specially designed heat dissipation radiator to prevent overheating 	<ul style="list-style-type: none"> • Electrical rating from 3 to 8A (single phase) and 5 to 7A (3 phase) • For all the commonly used refrigerants, including R410A • Enclosure: IP 65 (XGE) and IP54 (RGE) • Full CE / EMC approved • Dual frequency: 50/60 Hz • Max. working pressure: 47 bar • With low speed operation it is possible to select either minimum speed operation or cut-off operation

Technical data and ordering



Model	Mode ¹⁾	Pressure connection	Adjusting range [bar]	P-band [bar]	Pre-setting [bar]	Rated motor rating [A]	No. of phase/voltage [VAC]	Code no.
XGE-4C	C	1/4 in female flare	10-25	6	19	0.2-3	1 / 200-240	061H3140
XGE-4CB	C	1/4 in male flare	10-25	6	19	0.2-3	1 / 200-240	061H3142
XGE-6C	C	1/4 in female flare	22-39	7	28	0.2-3	1 / 200-240	061H3160
XGE-6CB	C	1/4 in male flare	22-39	7	28	0.2-3	1 / 200-240	061H3162
XGE-4M	M	1/4 in female flare	10-25	6	19	0.2-3	1 / 200-240	061H3240
XGE-4MB	M	1/4 in male flare	10-25	6	19	0.2-3	1 / 200-240	061H3242
XGE-6M	M	1/4 in female flare	22-39	7	28	0.2-3	1 / 200-240	061H3260
XGE-6MB	M	1/4 in male flare	22-39	7	28	0.2-3	1 / 200-240	061H3262
RGE-Z1N4-7DS	C or M	1/4 in female flare	8-28	4	19	0.2-4	1 / 200-240	061H3005
RGE-Z1N6-7DS	C or M	1/4 in female flare	16-39	8	32	0.2-4	1 / 200-240	061H3021
RGE-Z1P4-7DS	C or M	1/4 in female flare	8-28	4	19	0.2-6	1 / 200-240	061H3008
RGE-Z1P6-7DS	C or M	1/4 in female flare	16-39	8	32	0.2-6	1 / 200-240	061H3022
RGE-Z1Q4-7DS	C or M	1/4 in female flare	8-28	4	19	0.2-8	1 / 200-240	061H3009
RGE-Z1Q6-7DS	C or M	1/4 in female flare	16-39	8	32	0.2-8	1 / 200-240	061H3023
RGE-Z3R4-7DS	C or M	1/4 in female flare	8-28	4	16	0.2-5	3 / 200-240	061H3003
RGE-X3R4-7DS	C or M	1/4 in female flare	8-28	4	16	0.2-5	3 / 380-415	061H3006
RGE-Z3R6-7DS	C or M	1/4 in female flare	16-39	8	32	0.2-5	3 / 200-240	061H3027
RGE-X3R6-7DS	C or M	1/4 in female flare	16-39	8	32	0.2-5	3 / 380-415	061H3028
RGE-Z3T4-7DS	C or M	1/4 in female flare	8-28	4	16	0.2-7	3 / 200-240	061H3050
RGE-Z3T6-7DS	C or M	1/4 in female flare	16-39	8	32	0.2-7	3 / 200-240	061H3051

¹⁾ C = Cut-off, M = Min. speed

Accessories

Model	Description	Dimensions	Code no.
XGE-AE01	Fixing bracket accessory for panel mount	H: 38mm, W: 42mm, D: 45mm	061H3102





EKC 331T - Capacity control

The controller is used for capacity regulation of compressors or condensers in small refrigerating systems. Regulation can be carried out with up to four identical capacity steps.



Functions

- **Regulation**
Regulation with up to four relay outputs can be carried out. Regulation takes place with a set reference which is compared to a signal from a pressure transmitter or a temperature sensor.
- **Relay module**
It is possible to use the controller as relay module, so that the relays are cut in or out by means of an external voltage signal.
- **Alarmfunction**
A relay becomes activated when the set alarm limits are exceeded.
- **Digital input**
The digital input can be used for:
 - night operation where the suction pressure is raised
 - heat recovery where the condensing pressure is raised
 - external start/stop of the regulation.
 - Monitoring of safety circuit
- **Possibility of data communication**

Advantages

- **Patented neutral zone regulation**
- **Sequential or cyclic operation**

Technical data and ordering

Technical data

Supply voltage	230 V a.c. +/-15% 50/60 Hz, 5 VA	
Input signal	Pressure transmitter*) with 4-20 mA or temperature sensor Pt 1000 ohm or temperature sensor PTC 1000 ohm or voltage signal (0 - 5 V, 0 - 10 V or 5 - 10 V)	
	Digital input to external contact function	
Relay output	4 pcs. SPST	AC-1: 4 A (ohmic) AC-15: 3 A (inductive)
Alarmrelay	1 pcs. SPST	AC-1: 4 A (ohmic) AC-15: 1 A (inductive)
Data communication	Possible to connect a data communication module	
Environments	-10 - 55°C, during operation	
	-40 - 70°C, during transport	
	20 - 80% Rh, not condensed	
	No shock influence/vibrations	
Enclosure	IP 20	
Weight	300 g	
Mounting	DIN rail	
Display	LED, 3 digits	
Terminals	max. 2.5 mm ² multicore	
Approvals	EU Low voltage Directive and EMC demands re CE-marking complied with. LVD-tested acc. to EN 60730-1 and EN 60730-2-9 EMC-tested acc. to EN50081-1 and EN 50082-2	

*) As pressure transmitter can be used AKS 32R or AKS 33.

The installation of data communications must comply with the requirements described in literature sheet no. RC8AC

Ordering

Type	Function	Ordering
EKC 331T	Capacity controller	084B7105
EKA 175	Data communication module (accessories), (RS 485 module)	084B7093

Additional information!

Manual: RS8CU



AK-PC 530 - Capacity controller

The controller is used for capacity regulation of compressors or condensers in small refrigerating systems.

Numbers of compressors and condensers can be connected, as required.

There are eight outputs and more can be added via an external relay module.



Functions

- Relays for compressor and condenser regulation
- Voltage output for capacity regulation of condenser
- Status inputs. An interrupted signal indicates that the safety circuit has been activated and the respective circuit stopped
- Contact inputs for indication of alarms
- Contact inputs for displacement of references or for indication of alarms
- Alarm relay
- External start/stop of regulation
- Possibility of data communication

Advantages

- Patented neutral zone regulation
- Many possible combinations for compressor constellations
- Sequential or cyclic operation
- Possibility of suction pressure optimization via the data communication

Technical data and ordering

Technical data

Supply voltage	24 V a.c. +/-15% 50/60 Hz, 5 VA	
Input signal	2 pcs. Pressure transmitters type AKS 32R (temperature sensor in brine systems)	
	3 pcs. temperature sensor input for PT 1000 ohm/0°C or PTC 1000 ohm/25°C	
Digitale input from contact function.	1 pcs. for Start/stop of regulation	
	8 pcs. for monitoring of safety circuits	
	3 pcs. for alarm function	
	2 pcs. for alarm function or for displacement of references	
Relay output for capacity regulation	8 pcs. SPST	AC-1: 3 A (ohmic) AC-15: 2 A (inductive)
"AKD start/stop" relay	1 pcs. SPST	
Alarm relay	1 pcs. SPDT	AC-1: 6 A (ohmic) AC-15: 3 (inductive)
Voltage output	0-10 V d.c.	
Display outputs	EKA 163	Pc display
	EKA 165(164)	Operation, P0 display and LED
Data communication	Possible to connect a data communication module	
Environments	0 - 55°C, during operation	
	-40 - 70°C, during transport	
	20 - 80% Rh, not condensing	
	No shock influence / vibrations	
Enclosure	IP 20	
Weight	0.4 kg	
Mounting	DIN rail or on wall	
Terminals	max. 2.5 mm ² multicore	
Approvals	EU Low voltage Directive and EMC demands re CE-marking complied with. LVD-tested acc. to EN 60730-1 and EN 60730-2-9 EMC-tested acc. to EN61000-6-2 and 3	

Ordering

Type	Function	Code no.
AK-PC 530	Capacity controller	084B8007

Accessories

EKA 163B	Display unit	084B8574
EKA 164B	Display unit with operation buttons	084B8575
EKA 165	Display unit with operation buttons and light-emitting diodes for input and output	084B8573
EKA 173	Data communication module, FT10	084B7092
EKA 175	Data communication module, RS 485	084B7093
Cables	Cable for display unit 2 m, 1 pcs.	084B7298
	Cable for display unit 6 m, 1 pcs.	084B7299

Sensors and transmitters

Danfoss can supply a wide range of sensors and transmitters for electronic control of refrigeration applications.



Temperature sensors

- Temperature sensors are temperature dependent resistance sensors.
- Sensors in the AKS series are mainly for use in commercial and industrial refrigeration plants where the requirements on grade of enclosure and temperature range are high.
- The sensors are adjusted and meet the tolerance requirements of DIN IEC 751 class B.
- Sensors in the EKS series are mainly for use in air conditioning and comfort applications where there is a focus on the design of the unit and where the requirements to the temperature regulation are less demanding.
- The EKS sensors consist of a PTC element (1000 ohm at 25°C).

Pressure transmitters

- AKS pressure transmitters are designed for precise and energy optimized control.
- The robust design makes AKS suitable for a wide range of applications, such as:
 - Air conditioning systems-Refrigeration plants
 - Process control applications
 - Laboratory applications
- Product range:
 - 4 - 20 mA (AKS 33, AKS 3000)
 - 1 - 5 V d.c.,
 - 1 - 6 V d.c.,
 - 0 - 10 V d.c. (AKS 32)10
 - 90% ratiometric output (AKS 32R)

Technical data and code numbers

Temperature sensors

Type	Code number	Signal	Measure range	Sensor tube	Electrical connection	Cable length
EKS 111	084N1178	PTC1000	-55 100°C	Round	Cable with pins	1.5 m
EKS 111	084N1179	PTC1000	-55 100°C	Round	Cable with pins	3.5 m
EKS 111	084N1182	PTC1000	-55 100°C	Round	AMP Plug	3.5 m
EKS 211	084B4404	NTC5000	-40 80°C	Round	Cable	3.5 m
EKS 211	084N1220	NTC5000	-40 80°C	Round	Cable	1.5 m
AKS12	084N0036	PT1000	-40 80°C	Round	Cable	1.5 m
AKS12	084N0045	PT1000	-40 80°C	Round	AMP Plug	5.5 m
AKS 11	084N0003	PT1000	-50 100°C	Concave	Cable	3.5 m
AKS 11	084N0005	PT1000	-50 100°C	Concave	Cable	5.5 m
AKS 11	084N0008	PT1000	-50 100°C	Concave	Cable	8.5 m
AKS 21 M	084N2003	PT1000	-70 180°C	Round	Cable	2.5 m
AKS 21 W	084N2017	PT1000	-70 180°C	Sensor pipe	Cable	2.5 m
AKS 21 D	084N2035	PT1000	-40 80°C	Channel bulb	Terminal socket/ Type B	-
Accessories	060G1034				Plug 3 + E (female) + 5 m cable	-

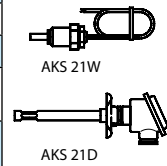

Pressure transmitters

Type	Code number	Signal	Measure range	Max. working pressure	Electrical connection	Connection
------	-------------	--------	---------------	-----------------------	-----------------------	------------

AKS 32/32R, 10-90% rated output signal, 4.75-8 V d.c., 0.3% FS

AKS 32	060G2069	0.5 4.5 V	-1/12 bar	33 bar	DIN 43650-A Connection without plug	7/16-20 UNF flare
AKS 32	060G2071	0.5 4.5 V	-1/34 bar	55 bar		
AKS 32R	060G0090	0.5 4.5 V	-1/12 bar	33 bar		
AKS 32R	060G1036	0.5 4.5 V	-1/34 bar	55 bar		

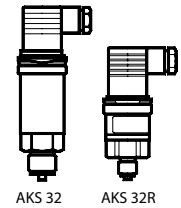

AKS 33, 4-20 mA output signal, 10-30V d.c. supply voltage, 0.3% FS

AKS 33	060G2048	4 20 mA	-1/6 bar	33 bar	DIN 43650-A Plug Pg 9	7/16-20 UNF flare
AKS 33	060G2049	4 20 mA	-1/12 bar	33 bar		
AKS 33	060G2045	4 20 mA	-1/25 bar	33 bar		
AKS 33	060G2051	4 20 mA	-1/34 bar	33 bar		G3/8 EN 837
AKS 33	060G2104	4 20 mA	-1/6 bar	33 bar		
AKS 33	060G2105	4 20 mA	-1/12 bar	33 bar		
AKS 33	060G2107	4 20 mA	-1/34 bar	33 bar		

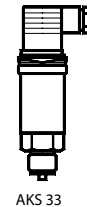

AKS 3000, 4-20 mA output signal, 10-30V d.c. supply voltage, 1.0% FS

AKS 3000	060G1323	4 20 mA	-1/12 bar	33 bar	DIN 43650-A Plug Pg 9	7/16-20 UNF flare
AKS 3000	060G1327	4 20 mA	0/30 bar	55 bar	DIN 43650-A Plug Pg 9	G3/8 EN 837
AKS 3000	060G1896	4 20 mA	-1/12 bar	33 bar	DIN 43650-A Plug Pg 9	G3/8 EN 837
AKS 3000	060G1041	4 20 mA	0/25 bar	40 bar	DIN 43650-A Plug Pg 9	G3/8 EN 837
AKS 3000	060G1066	4 20 mA	0/40 bar	100 bar	DIN 43650-A Plug Pg 9	G3/8 EN 837

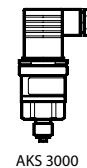

Level controls

Type	Code number	Signal	Length	Max. working pressure	Electrical connection	Pipe connection
AKS 41-3	084H4053	4 20 mA	280 mm	60 bar 60/100°C	DIN 43650-A Plug Pg 9	G 1A - ISO 228/1
AKS 41-5	084H4055	4 20 mA	500 mm			
AKS 41-8	084H4058	4 20 mA	800 mm			
AKS 41-10	084H4060	4 20 mA	1000 mm			
AKS 41-12	084H4062	4 20 mA	1200 mm			
AKS 41-15	084H40654	4 20 mA	1500 mm			
AKS 41-17	084H40674	4 20 mA	1700 mm			
AKS 41-22	084H40724	4 20 mA	2200 mm			

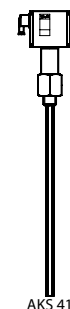



Compressors

Danfoss Compressors
– universal, innovative and energy-saving

At Danfoss Compressors, we have always been committed to satisfying the precise needs and expectations of our customers, over both the long and short term. More than 50 years' experience of compressor technology have taught us the requirements of our customers – and their customers – and has led to the creation of the world's most complete product range.

As a global leader in the field of refrigeration and air conditioning, we continuously strive to provide our customers with innovative solutions that are energy-efficient and environmentally-responsible.

Extensive product and application range

The Danfoss compressor range goes from small, direct current hermetic compressors for mobile applications, up to large scroll compressors for commercial air conditioning or industrial applications. Special versions, such as energy optimised compressors, variable speed compressors and compressors for solar applications are also available. The range covers all common HFC and HCFC refrigerants, as well as hydro-carbons for the smaller models.

Danfoss compressors are used in numerous applications, such as white goods, mobile refrigeration, light commercial refrigeration, commercial refrigeration and air conditioning.

Constant innovation, constant progress

As a part of Danfoss, Danfoss Compressors shares a tradition for technological leadership in many fields. Our contribution to the advancement of compressor technology is aimed at enhancing efficiency and environmental safety while reducing noise emissions. Danfoss was the first to market with R134a and R600a compressors, and we brought variable speed technology to the 220 V AC compressors category.

At Danfoss Compressors, two forces - the advancement of engineering technology and the demand for affordable refrigeration - will continue to drive us to develop the best technologies and processes in the design, manufacturing, and support of our products.

Danfoss – the number one choice of the world's leading refrigeration OEM manufacturers.



Direct current reciprocating compressors

Danfoss DC compressors perfectly suit applications like:

- Trucks
- Boats
- Recreational vehicles
- Medi boxes
- Ice cream stands in holiday resorts
- Portable cooling boxes
- Goods vehicles and trailers
- Cars
- Spot cooling systems

Tailored for cooling on the move

Designed for 12 V and 24 V direct current dual voltage, Danfoss DC compressors are designed for refrigeration in areas without a mains power supply, like cars, vans, boats and trucks.

The DC compressors BD35F/50F/80F/120CN/150CL and BD150F for 12 V and 24 V DC power supply are tailored to be used in both refrigerators and freezers with refrigerant R134a/R404A/R507/R290/R600a. They are equipped with an electronic unit that protects against overload and destructive battery discharge.

For 'spot cooling' systems, the BD350GH and BD350GH compressors are the right choice. Installed in, for example, sleeping cabins in trucks, the sleeping compartment of caravans, golf buggies, flight bridges on day cruisers and lift trucks, they lower the temperature and, at the same time, reduce humidity to a comfortable level.

Danfoss DC compressors are unsurpassed in tolerating changeable climatic conditions and vibrations under harsh road conditions, all over the world.

Product advantages	Customer benefits
<ul style="list-style-type: none"> · Efficient and reliable · Lasting performance · Low weight · Silent operation · Ideal for solar energy supply · Compact design · Energy optimisation · Speed/capacity control 	<ul style="list-style-type: none"> · Operation under extreme conditions · Minimal energy consumption · Portable beyond traditional limits · Low sound emission · Application possible at extreme voltage rate · Fits virtually anywhere · Safeguard for your food

Refrigerant	Compressor	Code no	Code no electronic device	rpm	Capacity (EN 12900 Household/CECOMAF9 12 V d.c. static cooling)													
					-40	-35	-30	-25	-23.3	-20	-15	-10	-5	0	5	7.2	10	15
R134a	BD 35F	101Z0200	101N0210	3500			26.2	35.9	40.4	50.5	69.8	93.6	122					
	BD 50 F	101Z1220	101N0210	3500			36.7	52.2	58.3	71.4	94.9	123*	157*					
	BD 80 F	101Z0280	101N0280	4400			54.8	78.0	86.7	105	138	176	221					
	BD150F	102G4784	105N4220	4000		78	111	153	170	205	269	345						
	BD250GH	101Z0400	101N0280	4400			62.9	70.7	87.0	116	149	175	189	236	290	316	353	425
	BD250/250GH	101Z0500	101N0280	4400				126	141	174	231	299	378	471	580	633	705	849
	BD350GH 24 V DC	101Z0720	101N0710	4400				132	148	183	243	314	397	495	609	665	740	891
	BD350GH 12 V DC	101Z0720	101N0700	4400				132	148	183	243	314	397	495	609	665	740	891
R290	BD100CN	101Z0401	101N0280	4400	44.6	62.4	83.4	108	117	137	170	209						
R600a	BD35K	101Z0211	101N0210	3500			24.9	36.0	40.2	49.3	65.1	83.8	106					

* Fan cooling of electronic unit compulsory
Power consumption is limited to 100 W with electronic unit 101N0500

Modern comfort is brought into life when leaving home. As people goes mobile, so does food. The excellent performance of the BD series safeguards food preservation. With our outstanding DC compressor for cars, vans, boats, trucks, etc., Danfoss has transcended the barriers for mobile refrigeration.

Even cooling without power supply

Thanks to an extensive voltage rate the BD compressors are ideal for solar energy supply. The exceptionally low starting current eliminates the need for current batteries if an ice bank is used for energy storage. When storing the sun energy in ice packs the cabinet can be kept at desired temperatures both night and day.

The direct current voltage compressors BD35F/50F/80F and BD150F for 12 V and 24 V DC power supply can be used in both refrigerators and freezers with refrigerant R134a/R290/R600a and are equipped with an electronic unit that protects against overload protection and destructive battery discharge.

This feature opens for numerous uses in areas without power supply like storage and transportation of drugs, ice cream stands in holiday resorts, food preservation under off road conditions, refrigerators in boats to name but a few.





Reciprocating compressors

Danfoss compressors perfectly suit applications like:

- Laboratory and medical equipment
- Clip-on units and condensing units
- Compressed air dryers
- Glass door merchandisers
- Bakery refrigeration equipment
- Ice cream cabinets
- Display cabinets – low temperature
- Vending machines
- Soft ice cream machines
- Ice making machines (ML/DL)
- Blast freezers
- Slush/frozen beverage makers
- Small coolers for trucks, working while stationary
- Heat pumps
- Milk cooling tanks
- Bottle coolers

Highly energy-efficient compressors for household and light commercial applications

Danfoss offers the world's most comprehensive and high-quality range of hermetic reciprocating compressors for refrigerators, freezers and light commercial applications, such as bottle coolers and display counters.

Available for use with refrigerant R134a, R404A, R407c, R600a and R290, for 115V 60Hz and 230V 50Hz/60Hz, they cover the whole spectrum of cooling needs for applications from 1.5 kW to 6 kW and enable considerable energy savings.

Danfoss hermetic reciprocating compressors deliver a high cooling capacity, particularly at low and very low evaporating temperatures, and are tailored to meet the wide range of specific requirements our customers demand. These include space-saving design, enhanced functionalities, low noise emission, high reliability and efficiency.

Product advantages	Customer benefits
<ul style="list-style-type: none"> · Smaller compressor dimensions or smaller displacements possible <ul style="list-style-type: none"> - Higher cooling capacity · Low noise level, innovative compressor technology · Low energy consumption <ul style="list-style-type: none"> - High cooling capacity - Improved COP · Small start equipment · High starting torque · High thermal working conditions <ul style="list-style-type: none"> - Oil and surface cooling - Integrated winding protection · High product quality · Wide voltage range: <ul style="list-style-type: none"> - 220-240 V 50 Hz programme - 208-230 V 60 Hz programme (contact Danfoss) - 115 V 60 Hz programme (contact Danfoss) · Dual frequency models 	<ul style="list-style-type: none"> · Extensive application range · Low sound emission · Low running costs · Reduced installation costs · Operation with thermostatic expansion valve possible · Application at high ambient temperature possible · High appliance and system robustness in rough operating conditions · Immune to unstable electric power supply

Displacement [cm ³]	Recommended compressor cooling at ambient temperature									Voltage and frequencies	Electrical Equipment						Compressor	
	32°C			38°C			43°C				LST (RSIR)		HST (CSIR)		HST (CSR)	LST/HST		
	LBP	MBP	HBP	LBP	MBP	HBP	LBP	MBP	HBP		PTC Starting device		Starting relay	Starting capacitor	Starting device	Cord relief		Cover
	spades		spades		spades		6.3 mm		4.8 mm		6.3 mm		6.3 mm		6.3 mm			
2.00		F2	F2		F2	F2				1/5	103N0011	103N0018	117U6021	117U5014		103N1010	103N0491	PL35G
2.61	S	S	S	S	S	S	S	S	F2	1/2/3/6	103N0011	103N0018	117U6007	117U5014		103N1010	103N2011	TL2.5G
3.13	S	S	F2	S	S	F2	S	S	F2	1/2/3	103N0011	103N0018	117U6009	117U5014		103N1010	103N2010	TL3G
3.86	S	S	F2	S	S	F2	S	S	F2	1/2/3	103N0011	103N0018	117U6004	117U5014		103N1010	103N2010	TL4G
5.08	S	S	F2	S	S	F2	S	S	F2	1/2/3	103N0011	103N0018	117U6000	117U5014		103N1010	103N2010	TL5G
6.23	S	S	F2	S	S	F2	S	S	F2	1/2/3	103N0011	103N0018	117U6000	117U5015		103N1010	103N2010	FR6G
6.93	S	F2	F2	S	F2	F2	O/F1	F2	F2	1/2/3	103N0011	103N0018	117U6001	117U5015		103N1010	103N2010	FR7.5G
7.95	S	F2	F2	O/F1	F2	F2	O/F1	F2	F2	1/2/3	103N0011	103N0018	117U6015	117U5015		103N1010	103N2010	FR8.5G
9.05	S	F2	F2	O/F1	F2	F2	O/F1	F2	F2	1/2/3	103N0011	103N0018	117U6010	117U5015		103N1010	103N2010	FR10G
11.15	F2	F2	F2	F2	F2	F2	F2	F2	F2	1/2	103N0011	103N0018	117U6010	117U5015		103N1010	103N2010	FR11G
10.29	F1	F1	F2	F1	F1	F2	F1	F1	F2	1/2/3	103N0002		117U6002	117U5017		103N1004	103N2009	SC10G
12.87	O/F1	F2	F2	O/F1	F2	F2	O/F1	F2	F2	1/2/3	103N0002		117U6003	117U5017		103N1004	103N2009	SC12G
15.28	O/F1	F2	F2	O/F1	F2	F2	O/F1	F2	F2	1/2/3			117U6005	117U5017		103N1004	103N2009	SC15G
17.69	O/F1	F2	F2	O/F1	F2	F2	O/F1	F2	F2	1/2/3			117U6019	117U5017		103N1004	103N2009	SC18G
20.95	F2	F2	F2	F2	F2	F2	F2	F2	F2	1/2/3					117-7028	103N1004	103N2009	SC21G
2 x 12.87	F2	F2	F2	F2	F2	F2	F2	F2	F2	1			117U6003	117U5017		103N1004	103N2009	SC12/12G
2 x 15.28	F2	F2	F2	F2	F2	F2	F2	F2	F2	1			117U6005	117U5017		103N1004	103N2009	SC15/15G
2 x 17.69	F2	F2	F2	F2	F2	F2	F2	F2	F2	1			117U6019	117U5017		103N1004	103N2009	SC18/18G
2 x 20.95	F2	F2	F2	F2	F2	F2	F2	F2	F2	1					117-7028	103N1004	103N2009	SC21/21G
2.50	S			S						1	103N0011	103N0018				103N1010	103N0491	PL50F
3.86	S			S						1	103N0011	103N0018	117U6009	117U5014		103N1010	103N2010	TL4F
5.08	S			S						1	103N0011	103N0018	117U6004	117U5014		103N1010	103N2010	TL5F
5.08	S			S						1	103N0011	103N0018	117U6004	117U5014		103N1010	103N2010	TL55F
5.70	S			S						1	103N0011	103N0018	117U6004	117U5014		103N1010	103N2010	TL56F
6.49	S			S*						1	103N0011	103N0018	117U6000	117U5014	103N0016	103N1010	103N2010	TL57F
6.13	S			S						1	103N0011	103N0018	117U6004	117U5015		103N1010	103N2010	NL6F
7.27	S			S						1	103N0011	103N0018	117U6000	117U5015		103N1010	103N2010	NL7F
7.95	S			S						1	103N0011	103N0018	117U6001	117U5015		103N1010	103N2010	NL8F
8.35	S			S						1	103N0011	103N0018	117U6001	117U5015		103N1010	103N2010	NL9F
11.15	O/F1			O/F1						1	103N0011	103N0018	117U6002	117U5015		103N1010	103N2010	NL11F
7.27	S	S		F1	F1					4/5			117U4140	117U5018		2x117U0349	117U1023	☐ NF7FX
10.09	F1	F1		F2	F2					4			117U4139	117U5018		2x117U0349	117U1021	☐ NF10FX
11.15	F2	F2		F2	F2					4			117U4139	117U5018		2x117U0349	117U1023	☐ NF11FX
15.28	O/F1			O/F1						1	103N0002		117U6003	117U5017		103N1004	103N2009	SC15F
17.69	O/F1			O/F1						1			117U6005	117U5017		103N1004	103N2009	SC18F
20.95	O/F1			O/F1						1			117U6019	117U5017		103N1004	103N2009	SC21F
26.30		F2			F2			F2		1	Starting device (start. relay, start. & run capacitor): 117-7055					107B9100/9101/9104 ☉ GS26MFX		
33.80		F2			F2			F2		1	Starting device (start. relay, start. & run capacitor): 117-7056					107B9100/9101/9104 ☉ GS34MFX		
3.86			F2			F2			F2	1/4			117U6000	117U5014		103N1010	103N2011	TL4GH
6.93			O/F1			O/F1			O/F1	1/4			117U6016	117U5015		103N1010	103N2011	FR7GH
10.29			F2			F2			F2	1/4			117U6005	117U5019		103N1004	103N2008	SC10GH
12.87			F2			F2			F2	1/4			117U6011	117U5019		103N1004	103N2008	SC12GH
15.28			F2			F2			F2	1/4			117U6011	117U5019		103N1004	103N2008	SC15GH
17.69			F2			F2			F2	1			117U6019	117U5017		103N1004	103N2009	SC18GH
17.69			F2			F2			F2	1/4					117-7038	103N1004	103N2008	SC18GH
15.28			O			O			O	1					117-7012	103N1004	103N2009	SC15GHH

Applications

LBP: Low Back Pressure
HBP: High Back Pressure
MBP: Medium Back Pressure

Motor types

RSIR: Resistant Start Induction Run
RSCR: Resistant Start Capacitor Run
CSIR: Capacitor Start Induction Run
CSR: Capacitor Start Run

Starting devices

LST: Low Starting Torque
LST is used with capillary tube control and pressure equalizing. (Pressure equalizing may exceed 10 minutes). The PTC starting device requires 5 minutes cooling before each start.

Note: To fulfil the requirements of EN 60355-2-34 the protection screen 103N0476 must be applied to the PTC starting device.

HST: High Starting Torque

HST consisting of relay and starting capacitor, is used for expansion valve control or for capillary tube control without pressure equalizing.

Test conditions EN 12900 (CECOMAF)

PL/TL/TLS/TLES/NL/NLE/FR/SC

Application **R134a**
Condensing temperature 55°C
Ambient temperature 32°C
Suction gas temperature 32°C
Liquid temperature 55°C
220 V / 50 Hz

Test conditions EN 12900 (CECOMAF)

GS

Application **MPB** **HBP**
Condensing temperature 45°C 50°C
Ambient temperature 32°C 32°C
Suction gas temperature 20°C 20°C
Liquid temperature no subcooling
220 V / 50 Hz

Compressor cooling

S = Static cooling normally sufficient
O = Oil cooling
F₁ = Fan cooling 1.5 m/s (compressor compartment temp. equal to ambient temperature)
F₂ = Fan cooling 3.0 m/s necessary
* = O/F1 possible at 220 V nominal (187-242 V)

Voltages and frequencies

1 = 198-254 V, 50 Hz
2 = 187-254 V, 50 Hz, LBP
3 = 198-254 V, 60 Hz, LBP
4 = 198-254 V, 60 Hz
5 = 198-254 V, 60 Hz, MBP
6 = 207-254 V, 60 Hz, HBP

1 Watt = 0.86 kcal/h
1 Watt = 3.41 Btu/h

R134a hermetic compressors • 220-240 V • 50 Hz

Compressor	Dimensions					
	Height [mm]		Connectors location/I.D. [mm]			
	A	B	Suction C	Process D	Discharge E	Oil cooler F
PL35G	137	135	6.2	6.2	5.0	
TL2.5G	163	159	6.2	6.2	5.0	
TL3G	163	159	6.2	6.2	5.0	
TL4G	173	169	6.2	6.2	5.0	
TL5G	173	169	6.2	6.2	5.0	
FR6G	196	191	8.2	6.2	6.2	
FR7.5G	196	191	8.2	6.2	6.2	6.2
FR8.5G	196	191	8.2	6.2	6.2	6.2
FR10G	196	191	8.2	6.2	6.2	6.2
FR11G	196	191	8.2	6.2	6.2	
SC10G	199	193	8.2	6.2	6.2	
SC12G	209	203	8.2	6.2	6.2	6.2
SC15G	209	203	10.2	6.2	6.2	6.2
SC18G	219	213	8.2	6.2	6.2	6.2
SC21G	219	213	10.2	6.2	6.2	
SC12/12G	249	244	12	6.2	6.2	
SC15/15G	249	244	12	6.2	6.2	
SC18/18G	259	254	16	6.2	6.2	
SC21/21G	259	254	16	6.2	6.2	
PL50F	137	135	6.2	6.2	5.0	
TL4F	163	159	6.2	6.2	5.0	
TL5F	173	169	6.2	6.2	5.0	
TL55F	173	169	6.2	6.2	5.0	
TL56F	173	169	6.2	6.2	5.0	
TL57F	173	169	6.2	6.2	5.0	
NL6F	188	181	6.2	6.2	5.0	
NL7F	190	183	6.2	6.2	5.0	
NL8F	197	191	6.2	6.2	5.0	
NL9F	197	191	8.2	6.2	6.2	6.2
NL11F	203	197	8.2	6.2	6.2	6.2
□ NF7FX	203	197	8.2	6.5	6.5	
□ NF10FX	203	197	8.2	6.5	6.5	
□ NF11FX	203	197	8.2	6.5	6.5	
SC15F	209	203	8.2	6.2	6.2	6.2
SC18F	209	203	10.2	6.2	6.2	6.2
SC21F	219	213	10.2	6.2	6.2	6.2
○ GS26MFX	259	247	12.9	6.5	8.2	
○ GS34MFX	259	247	12.9	6.5	8.2	
TL4GH	173	169	6.2	6.2	5.0	
FR7GH	196	191	8.2	6.2	8.2	8.2
SC10GH	199	193	10.2	6.2	8.2	
SC12GH	209	203	10.2	6.2	8.2	
SC15GH	209	203	10.2	6.2	8.2	
SC18GH	219	213	10.2	6.2	8.2	
SC18GH	219	213	10.2	6.2	8.2	
SC15GHH	209	203	10.2	6.2	8.2	8.2

○ = preliminary data

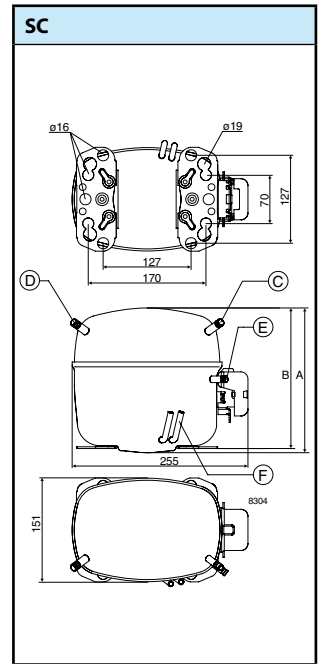
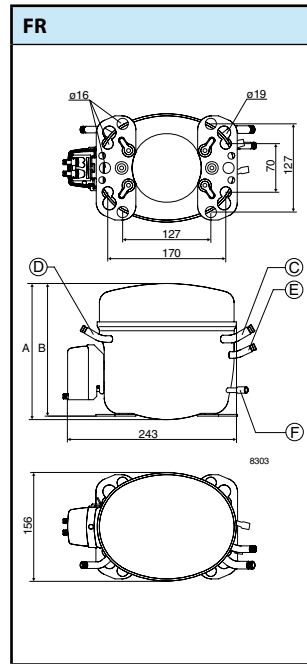
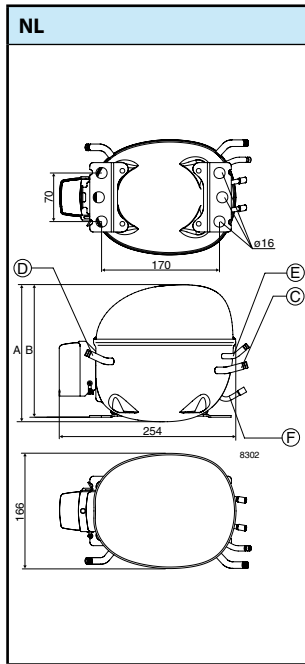
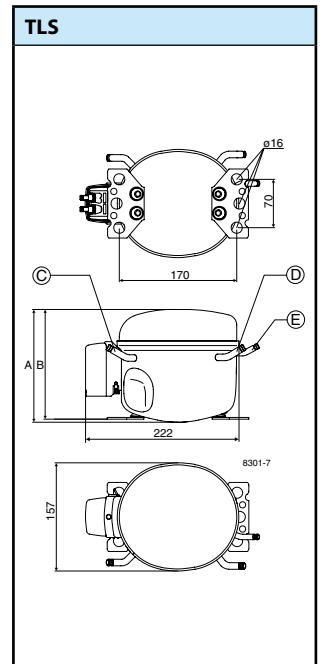
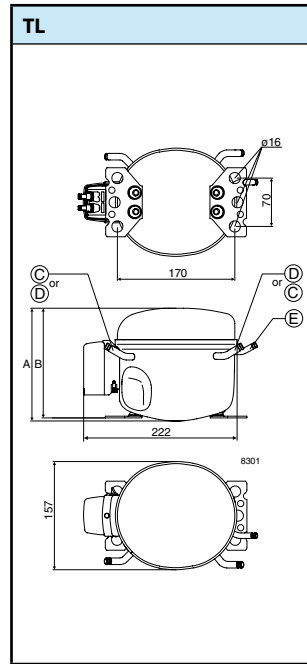
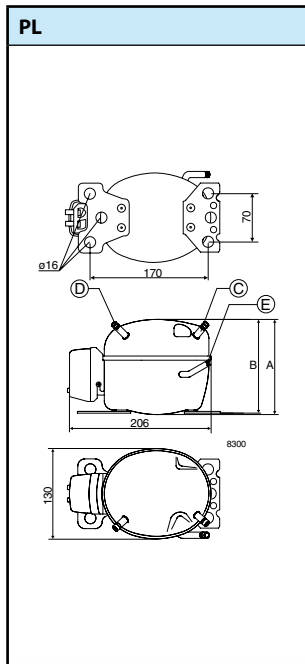

Mounting accessories

Bolt joint for one compressor: **118-1917**
in quantities: **118-1918**

Bolt joint for one GS compressor: **107B9150**

Snap-on in quantities: **118-1919**

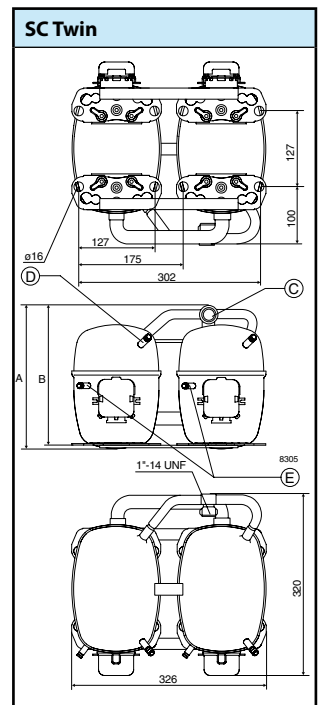
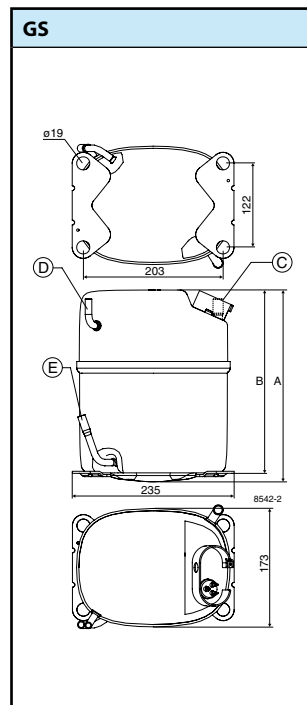

LST - RSIR

PL

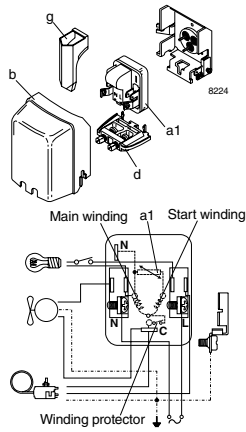

TL-TLS-NL-FR

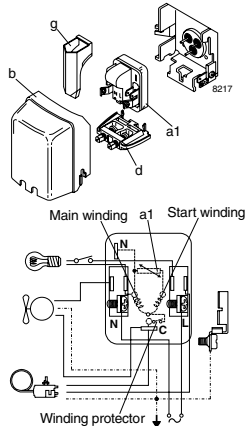

SC

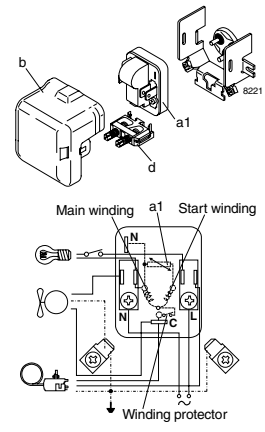

HST - CSIR

PL

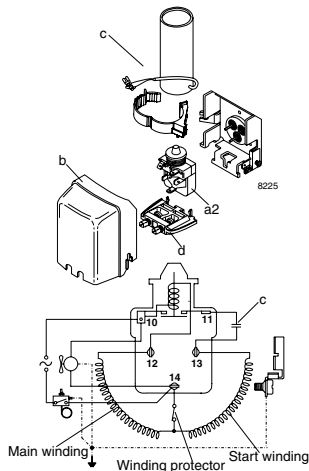

TL-TLS-NL-FR

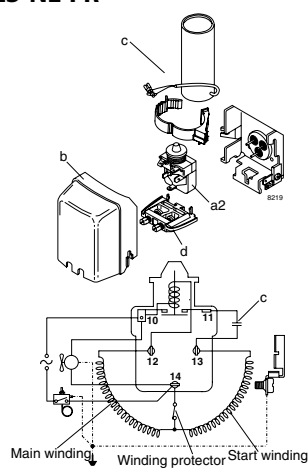

SC

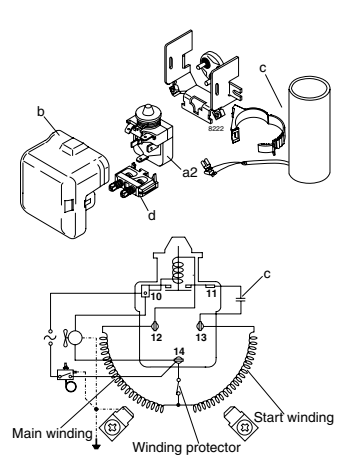

HST - CSR

SC

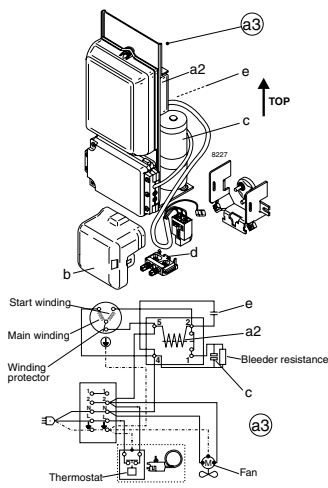

GS

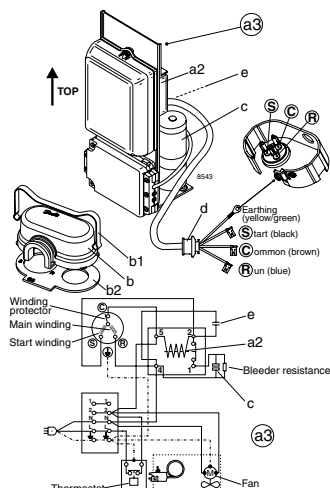

Legend

- a1: PTC starting device
- a2: Starting relay
- a3: Starting device
- b: Cover
- b1/b2: Clamp/Gasket (parts of compressor)
- c: Starting capacitor
- d: Cord relief
- e: Run capacitor
- g: Protection screen for PTC

HST - CSR

SCTwin

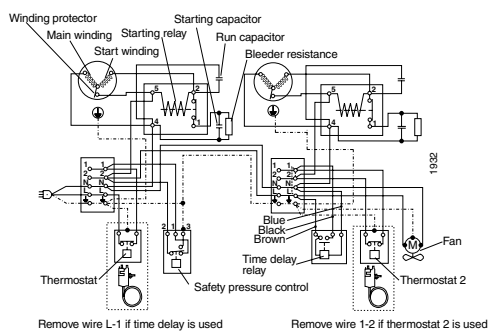

HST - CSIR

SCTwin

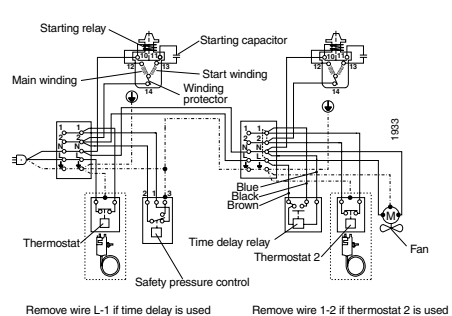

R404A/R507 hermetic compressors · 220-240 V · 50 Hz & 60 Hz incl. GEEP range

Refrigerant Application	Compressor incl. the GEEP™ range	Compressor code number ²⁾	EN 12900 (CECOMAF)																				
			Capacity [W]																				
			Evaporating temperature [°C]																				
-45	-40	-35	-30	-25	-23.3	-20	-15	-10	-6.7	-5	0	5	7.2	10	15								
1 Phase	R404A	LBP	TL4CL	102U2071	52	65	84	110	142	155	182	230	286	328	352								
			TL4.5CLX	102U2111	80	106	139	181	197	232	294	366											
			FR6CL	103U2670	77	108	145	189	243	263	307	383	473	541	578								
			FR7.5CL	103U2790	86	114	154	202	262	285	333	418	515	587	630								
			FR8.5CL	103U2890	99	126	168	222	290	317	372	468	577										
			NL7CLX	105F3710	102	146	199	263	340	369	430	536	657	746	796								
			NL8.4CLX ○	105F3800	111	158	216	287	370	402	468	583	715	812	866								
			SC10CLX ¹⁾	104L2533			166	255	360	400	483	625	789	910	977	1190	1430						
			SC12CLX.2 ¹⁾	104L2697	130	205	294	399	522	569	666	834	1026										
			SC15CLX.2 ¹⁾	104L2896	159	250	358	486	637	694	813	1017	1251	1424	1519								
			SC18CLX.2 ¹⁾	104L2197	194	306	439	595	780	849	995	1245	1532										
			SCE18CLX.2 ¹⁾	104L2196	194	306	439	595	780	849	995	1245	1532										
			SC21CL	104L2322	226	325	455	617	813	887	1042	1306	1606										
			GS26CLX * GEEP™	107B0500	325	497	703	949	1240	1348	1580	1974	2427										
			GS34CLX * GEEP™	107B0501		721	986	1297	1663	1807	2092	2577	3120										
	NTZ048 ¹⁾	120F0089	261	527	964	1405	1931	2131	2550	3270	4100												
	NTZ068 ¹⁾	120F0090	779	1130	1756	2332	3030	3297	3863	4849	6001												
	MBP	NF7MLX	105F3720							526	645	733	781	936	1110	1193	1305						
		SC10MLX	104L2506						465	546	687	855	981	1051	1278	1537							
		SC12MLX	104L2606						572	669	838	1038	1188	1272	1542	1852	2001						
		SC15MLX	104L2869						710	829	1038	1285	1471	1574	1909	2293	2478						
		SC18MLX	104L2139						831	968	1210	1497	1712	1832	2220	2665	2880						
		SC18MLX.3	104L2146						876	1018	1266	1557	1779	1898	2292	2743	2964						
		GS21MLX * GEEP™	107B0502								1419	1777	2044	2186	2642	3140	3354						
		GS26MLX * GEEP™	107B0503								1535	1917	2365	2680	2854	3401	3990	4260					
		GS34MLX * GEEP™	107B0504								1925	2397	2952	3359	3585	4286	5060	5418					
		MPZ038 ¹⁾ GEEP™	120F0153				851	1289	1426	1722	2257	2904	3399	3675	4580	5628	6138	6831					
		MPZ048 ¹⁾ GEEP™	120F0154				1214	1823	2006	2398	3091	3914	4535	4881	6004	7298	7924	8774					
MPZ054 ¹⁾ GEEP™		120F0155				1250	1997	2224	2700	3518	4465	5168	5555	6803	8222	8968	9826						
MPZ061 ¹⁾ GEEP™		120F0156				1484	2368	2580	3106	4003	5030	5786	6201	7528	9023	9738	10700						
MPZ068 ¹⁾ GEEP™	120F0157				1889	2828	3098	3665	4636	5758	6591	7051	8530	10215	11026	12123							
HBP	TL4DL	102U2038						196	229	281	329	349	432	527	631								
	FR6DL	103U2680						317	385	471	538	576	698	840	907	999	1177						
	SC10DL	104L2525						471	611	775	899	968	1192	1450	1576	1747	2085						
	SC12DL	104L2625						609	806	1028	1190	1279	1565	1890	2046	2258	2674						
	SC15DL	104L2856						759	964	1207	1391	1493	1825	2210	2397	2652	3156						
	SC10/10DL	104L4091						943	1222	1550	1798	1935	2383	2900	3152	3494	4169						
	SC12/12DL	104L4092						1217	1612	2055	2380	2559	3130	3780	4092	4516	5348						
SC15/15DL	104L4093						1518	1928	2414	2781	2985	3651	4420	4795	5304	6311							
3 Phase	R404A	LBP	NTZ048 ¹⁾	120F0008	289	558	995	1424	1931	2122	2522	3204	3987										
			NTZ068 ¹⁾	120F0009	673	1075	1750	2380	3122	3402	3988	4992	6146										
		MBP	MPZ038 ¹⁾ GEEP™	120F0057				879	1342	1484	1791	2339	2995	3492	3770	4673	5715	6220	6906				
			MPZ048 ¹⁾ GEEP™	120F0058				1173	1846	2047	2467	3183	4005	4611	4943	6009	7212	7788	8563				
			MPZ054 ¹⁾ GEEP™	120F0059				1250	1997	2700	2224	3518	4465	5168	5555	6803	8222	8904	9826				
			MPZ061 ¹⁾ GEEP™	120F0060				1484	2328	3106	2580	4003	5030	5786	6201	7528	9023	9738	10700				
			MPZ068 ¹⁾ GEEP™	120F0061				1777	2732	3011	3592	4579	5707	6537	6992	8449	10093	10880	11940				

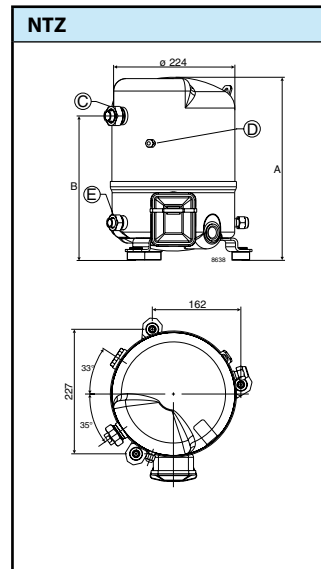
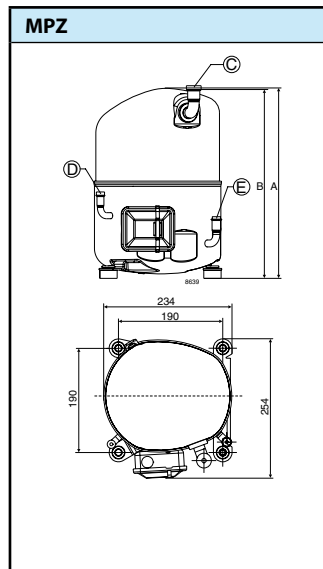
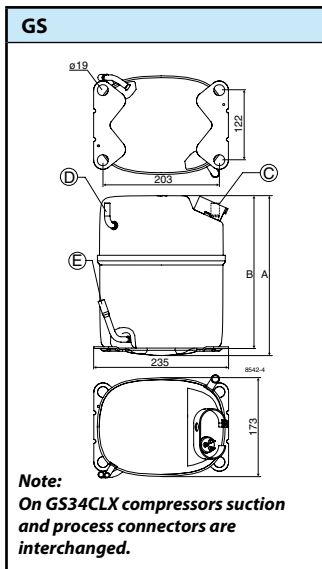
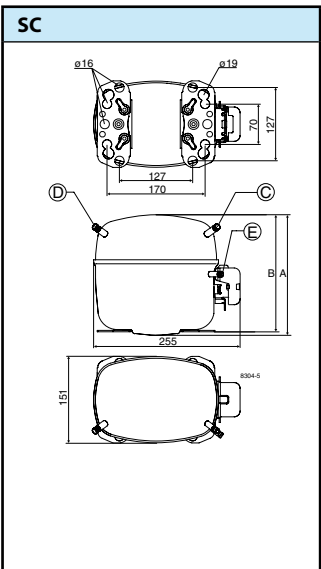

EN 12900 (CECOMAF)					Displacement [cm ³]	Recommended compressor cooling at ambient temperatures									Voltage and frequencies	Electrical equipment (HST), spade dimensions					Single pack code number
Power consumption [W]						32 °C			38 °C			43 °C				HST (CSIR)		HST (CSR)	LST/HST		
Evaporating temp. [°C]						LBP	MBP	HBP	LBP	MBP	HBP	LBP	MBP	HBP		Starting relay	Starting capacitor	Starting device	Cord relief	Cover	
-35	-25	-10	5			spades			spades			spades				6.3 mm					
105	140	198		3.86	F ₂	F ₂		F ₂	F ₂					1	117U6000	117U5014		103N1010	103N2010		
138	181	252		4.63	F ₂			F ₂				F ₂			7	117U6001	117U5014		103N1004	117U1022	
180	242	353		6.23	F ₂	F ₂		F ₂	F ₂					1	117U6015	117U5015		103N1010	103N2010		
197	267	395		6.93	F ₂	F ₂		F ₂	F ₂					1	117U6016	117U5015		103N1010	103N2010		
231	315	472		7.95	F ₂			F ₂						1	117U6010	117U5015		103N1010	103N2010		
214	274	381		7.27	F1	F1		F1	F1			F ₂	F ₂	1	117U6002	117U5015		103N1010	103N2010		
271	305	428		8.35	F ₂	F ₂		F ₂	F ₂			F ₂	F ₂	7	117U6003	117U5015		103N1010	103N2010		
258	352	508	631	10.29	F ₂	F ₂		F ₂	F ₂						117U6005	117U5019		103N1004	103N2008	195B0151	
365	475	659		12.87	F ₂			F ₂							117U6019	117U5019		103N1004	103N2008	195B0379	
433	565	783		15.28	F ₂			F ₂				F ₂			117U6019	117U5017		103N1004	103N2009	195B0399	
517	680	949		17.68	F ₂			F ₂				F ₂			117U6013	117U5012		103N1004	103N2009	195B0332	
459	621	888		17.68	F ₂			F ₂				F ₂					117-7012	103N1004	103N2009	on request	
534	702	989		20.95	F ₂			F ₂									117-7012	103N1004	103N2009	195B0070	
669	888	1285		26.30	F ₂			F ₂				F ₂					117-7056	107B9100/9101/9104		195B0427	
909	1165	1696		33.80	F ₂			F ₂									117-7074	107B9100/9101/9104		195B0439	
1342	1885			48.1	SG	SG		SG	SG			SG	SG				7701028		8156134	120F0087	
2067	2936			67.9	SG	SG		SG	SG			SG	SG				7701028		8156134	120F0088	
	398	556		7.27		F ₂			F ₂			F ₂		7	117U4139	117U5018		2x117U0349	117U1021		
	518	633		10.29		F ₂			F ₂			F ₂			117U6011	117U5019		103N1004	103N2009	195B0345	
	620	762		12.87		F ₂			F ₂			F ₂			117U6011	117U5019		103N1004	103N2009	195B0323	
	780	979		15.28		F ₂			F ₂						117U6013	117U5012		103N1004	103N2009	195B0391	
	860	1080		17.68		F ₂			F ₂								117-7012	103N1004	103N2009	195B0392	
	878	1096		17.68		F ₂			F ₂								117-7012	103N1004	103N2009	195B0412	
	981	1210		21.20		F ₂			F ₂			F ₂					117-7070	107B9100/9101/9104		195B0436	
	1207	1478		26.30		F ₂			F ₂			F ₂					117-7072	107B9100/9101/9104		195B0437	
	1722	2204		33.80		F ₂			F ₂			F ₂					117-7073	107B9100/9101/9104		195B0438	
	930	1374	1711	38.1		SG			SG			SG									120F0143
	1326	1869	2352	48.1		SG			SG			SG									120F0144
	1420	2154	2725	53.9		SG			SG			SG									120F0145
	1676	2522	3159	60.5		SG			SG			SG									120F0146
	2091	2965	3682	67.9		SG			SG			SG									120F0147
	203	256		3.86	F ₂	F ₂		F ₂	F ₂					1	117U6001	117U5014		103N1010	103N2010		
	354	456		6.23	F ₂	F ₂		F ₂	F ₂					1	117U6010	117U5015		103N1010	103N2010		
	479	590		10.29	F ₂	F ₂		F ₂	F ₂					1	117U6005	117U5017		103N1004	103N2009		
	624	750		12.87	F ₂	F ₂		F ₂	F ₂					1	117U6019	117U5017		103N1004	103N2009		
	722	865		15.28	F ₂	F ₂		F ₂	F ₂					1			117-7028	103N1004	103N2009		
	957	1180	2x10.29		F ₂	F ₂		F ₂	F ₂					1	117U6005	117U5017		103N1004	103N2009		
	1248	1500	2x12.87		F ₂	F ₂		F ₂	F ₂					1	117U6019	117U5017		103N1004	103N2009		
	1445	1730	2x15.28		F ₂	F ₂		F ₂	F ₂					1			117-7028	103N1004	103N2009		
	1328	1884		48.1	SG	SG		SG	SG			SG	SG						8156134		120F0001
	2017	2843		67.9	SG	SG		SG	SG			SG	SG						8156134		120F0002
	966	1419	1739	38.1		SG			SG			SG									120F0047
	1288	1896	2361	48.1		SG			SG			SG									120F0048
	1420	2154	2725	53.9		SG			SG			SG									120F0049
	1676	2522	3159	60.5		SG			SG			SG									120F0050
	1942	2905	3706	67.9		SG			SG			SG									120F0051

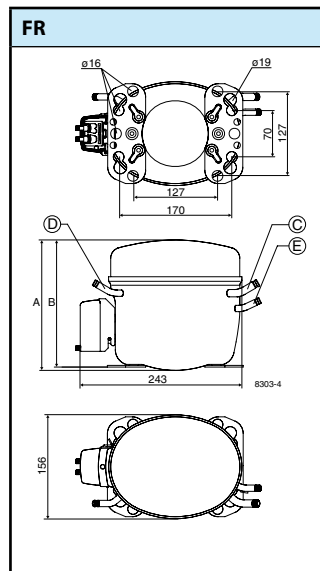
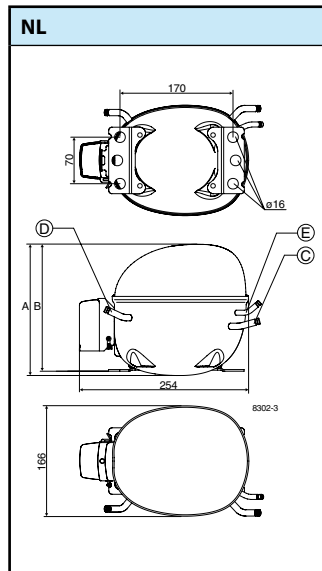
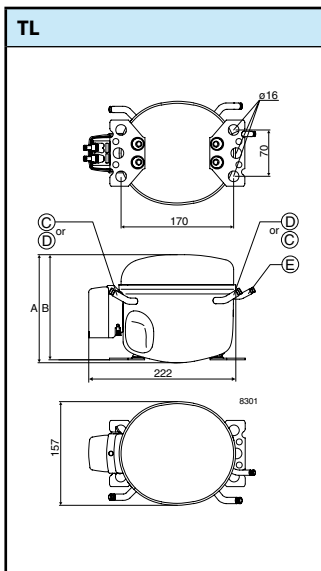

¹⁾available for 60 Hz also

R404A/R507 hermetic compressors · 220-240 V · 50 Hz & 60 Hz incl. GEEP range

Refrigerant	Application	Compressor incl. the GEEP™ range	Dimensions								
			Height [mm]		Connectors location/I.D. [mm]						
			A	B	Suc- tion C	Pro- cess D	Dis- charge E				
1 Phase	R404A	LBP	TL4CL	173	169	6.2	6.2	5.0			
			TL4.5CLX	173	169	6.2	6.2	5.0			
			FR6CL	196	191	8.2	6.2	6.2			
			FR7.5CL	196	191	8.2	6.2	6.2			
			FR8.5CL	196	191	8.2	6.2	6.2			
			NL7CLX	203	197	8.2	6.2	6.2			
			NL8.4CLX	203	197	8.2	6.2	6.2			
			SC10CLX ¹⁾	209	203	8.2	6.2	6.2			
			SC12CLX.2 ¹⁾	219	213	8.2	6.2	6.2			
			SC15CLX.2 ¹⁾	219	213	10.2	6.2	6.2			
	SC18CLX.2 ¹⁾	219	213	10.2	6.2	6.2					
	SCE18CLX.2 ¹⁾	219	213	10.2	6.2	6.2					
	SC21CL	219	213	10.2	6.2	6.2					
	GS26CLX * GEEP™	259	247	12.9	6.5	8.2					
	GS34CLX * GEEP™	259	247	12.9	6.5	8.2					
	NTZ048 ¹⁾	333	263	5/8"	Flare	1/2"					
	NTZ068 ¹⁾	333	263	5/8"	Flare	1/2"					
	R404A	MBP	NF7MLX	203	197	9.7	6.5	6.5			
			SC10MLX	209	203	8.2	6.5	6.5			
			SC12MLX	219	213	8.2	6.5	6.5			
SC15MLX			219	213	10.2	6.2	6.2				
SC18MLX			219	213	10.2	6.2	6.2				
SC18MLX.3			219	213	10.2	6.2	6.2				
GS21MLX * GEEP™			259	247	12.9	6.5	8.2				
GS26MLX * GEEP™			279	267	16.1	6.5	9.7				
GS34MLX * GEEP™			279	267	16.1	6.5	9.7				
MPZ038 ¹⁾ GEEP™			356	342	3/4"	3/8"	1/2"				
1 Phase	R404A	HBP	TL4DL	173	169	6.2	6.2	5.0			
			FR6DL	196	191	8.2	6.2	6.2			
			SC10DL	209	203	8.2	6.2	6.2			
			SC12DL	219	213	10.2	6.2	6.2			
			SC15DL	219	213	10.2	6.2	6.2			
			SC10/10DL	249	244	12	6.2	6.2			
			SC12/12DL	249	244	12	6.2	6.2			
			SC15/15DL	259	254	16	6.2	6.2			
			3 Phase	R404A	LBP	NTZ048 ¹⁾	333	263	5/8"	Flare	1/2"
						NTZ068 ¹⁾	333	263	5/8"	Flare	1/2"
MBP	MPZ038 ¹⁾ GEEP™	348			346	3/4"	3/8"	1/2"			
	MPZ048 ¹⁾ GEEP™	348			346	3/4"	3/8"	1/2"			
	MPZ054 ¹⁾ GEEP™	348			346	3/4"	3/8"	1/2"			
	MPZ061 ¹⁾ GEEP™	348			346	3/4"	3/8"	1/2"			
MPZ068 ¹⁾ GEEP™	348	346	3/4"	3/8"	1/2"						

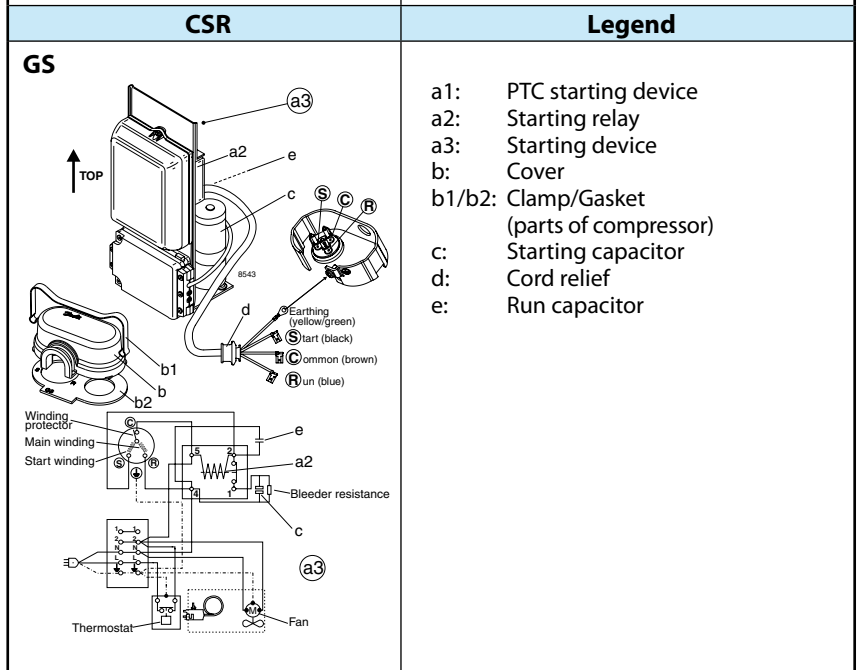
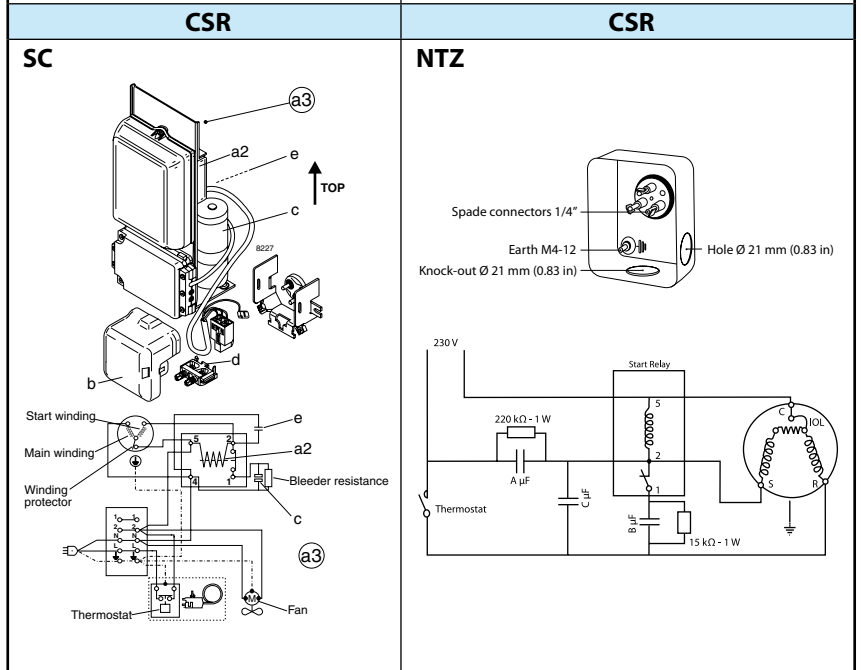
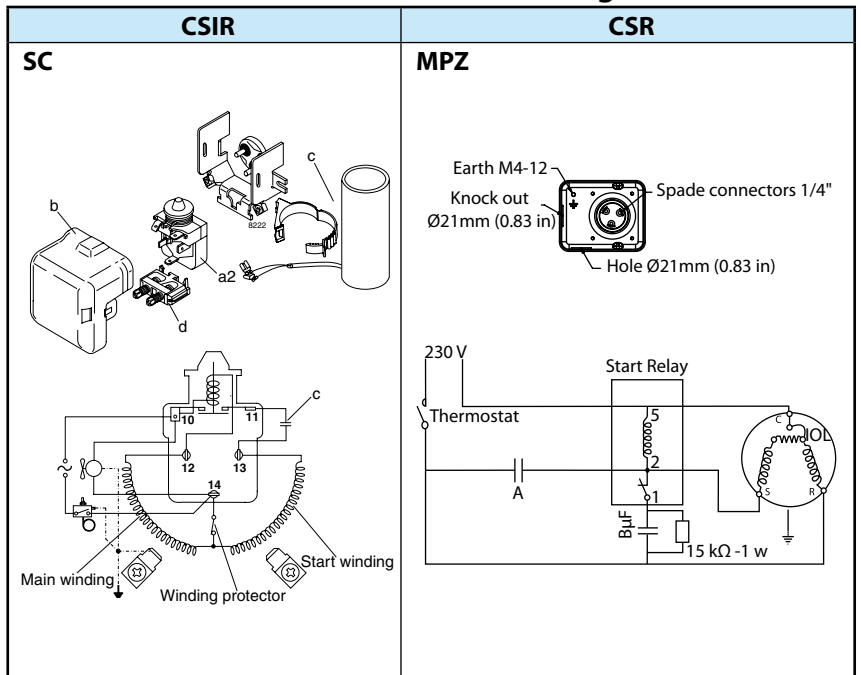

HST - CSIR

TL4.5CLX

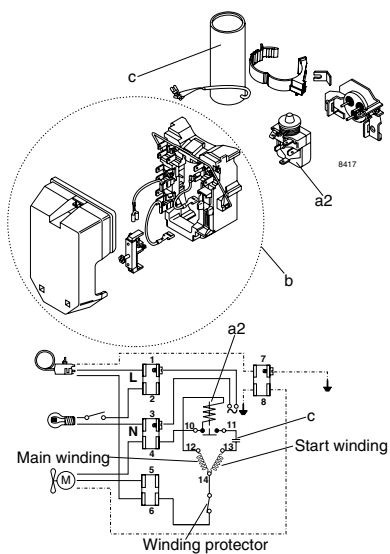

TL-NL-FR

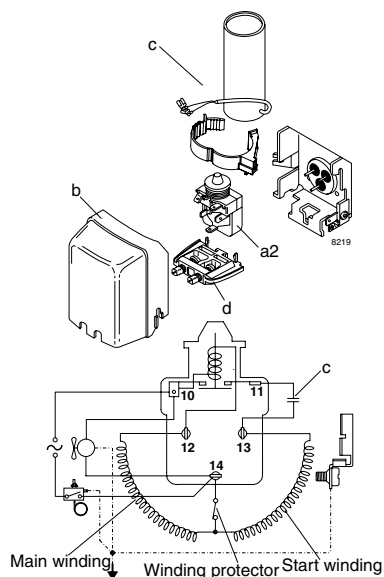

Hermetic compressors type TL, NL, FR, SC, GS, MPZ, NTZ R404A/R507

Applications

LBP: Low Back Pressure
MBP: Medium Back Pressure
HBP: High Back Pressure

Motor types

CSIR: Capacitor Start Induction Run
CSR: Capacitor Start Run

Starting devices

HST: High Starting Torque

Test conditions EN 12900 (CECOMAF)

TL/NL/FR/SC

Application **R404A/R507**
 Condensing temperature 45°C
 Ambient temperature 32°C
 Suction gas temperature 32°C
 No subcooling
 220 V / 50 Hz

Test conditions EN 12900

GS/NTZ/MPZ:

Condensing temp. LBP 40°C
 Condensing temp. MBP 45°C
 Condensing temp. HBP 50°C
 Ambient temperature 32°C
 Suction gas temperature 20°C
 NTZ at $T_e = -45^\circ\text{C}, -40^\circ\text{C}$
 MPZ at $T_e = -30^\circ\text{C}$
 Liquid temperature no subcooling
 220 V / 50 Hz
 230 V / 1 ph / 50 Hz
 400 V / 3 ph / 50 Hz

Compressor cooling

S = Static cooling normally sufficient
 O = Oil cooling
 F1 = Fan cooling 1.5 m/s
 (compressor compartment temp.
 equal to ambient temperature)
 F2 = Fan cooling 3.0 m/s necessary
 F2 = Fan cooling 3.0 m/s necessary
 SG = Suction gas cooling normally
 sufficient



Reciprocating Compressors

Danfoss Maneurop compressors perfectly suit applications like:

- Walk-in freezers & cold rooms
- Frozen food processing and storage
- Blast freezers
- Low temperature racks
- Ice flake machines
- Ice cream machines
- Display cabinets
- Water chillers
- Large packaged air conditioners

Universal compressors for commercial refrigeration and air conditioning applications

Designed for refrigeration as well as air conditioning applications with refrigerants R22, R407C, R134a, R404A and R507A, the Maneurop range covers all requirements in the 1.5 to 26 HP range.

Thanks to a very large internal volume, large oil sump, the sturdy design of the compression parts and its 100% suction gas-cooled electric motor, the Maneurop reciprocating compressor has consistently proven itself capable of withstanding the harshest conditions.

The range consists of single compressors with rotolock connections, suitable for parallel mounting as well as factory-made tandem units.

Maneurop compressors are used in a large array of applications in a variety of businesses, ranging from water chillers to large packaged air conditioners, as well as medium and low temperature refrigeration systems for food storage and processing.

Product advantages	Customer benefits
<ul style="list-style-type: none"> • Efficient and reliable • Designed for multiple applications • Rugged • Designed for high, medium and low evaporating temperature applications • Quick pull down capabilities • 100% suction gas-cooled motor • Internal motor protection • High efficiency circular valve design • High torque motors 	<ul style="list-style-type: none"> • Operation under extreme conditions • Versatile: Suitable for air conditioning as well as chilling applications • No need for air circulation around the compressor • Simple to use • Flexibility of location • High limit on maximum operating condensing temperature

PRODUCT RANGE

Model	Configuration	Nominal voltage								
		208-230/1/60	200-230/3/60	400/3/50 460/3/60	230/1/50	230/3/50	500/3/50 575/3/60	380/3/60		
		Motor voltage code								
		1	3	4	5	6	7	9		
MT/MTZ018	1 cylinder									
MT/MTZ022										
MT/MTZ028										
MT/MTZ032										
MT/MTZ036										
MT/MTZ040										
MT/MTZ044										
MT/MTZ045		2 cylinders								
MT/MTZ050										
MT/MTZ051										
MT/MTZ056										
MT/MTZ057										
MT/MTZ064										
MT/MTZ065										
MT/MTZ072										
MT/MTZ073										
MT/MTZ080										
MT/MTZ081	4 cylinders									
MT/MTZ100										
MT/MTZ125										
MT/MTZ144										
MT/MTZ160										
MTM/MTZ200 T		Tandem 2 x 4								
MTM/MTZ250 T										
MTM/MTZ288 T										
MTM/MTZ320 T										
LTZ022*	1 cyl.									
LTZ028*										
LTZ040*	2 cyl.									
LTZ044*										
LTZ050*	4 cyl.									
LTZ088*										
LTZ100*										
LTZ176 T*										
LTZ200 T*	2 x 4									
NTZ048		1 cyl.	120F0072	120F0029	120F0001	120F0087				
NTZ068	120F0073		120F0031	120F0002	120F0088					
NTZ096	2 cyl.	120F0074	120F0033	120F0003						
NTZ108		120F0075	120F0035	120F0004						
NTZ136		120F0076	120F0037	120F0005						
NTZ215	4 cyl.		120F0039	120F0006						
NTZ271			120F0041	120F0007						
NTZ430 T				120F0024						
NTZ542 T	2 x 4			120F0025						

1 cylinder
 D : 225 mm
 H : 333/358 mm
 H1 : 263 mm
 H2 : 68 mm

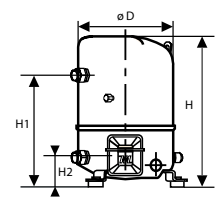

2 cylinders
 D : 288 mm
 H : 415 mm
 H1 : 266 mm
 H2 : 75 mm

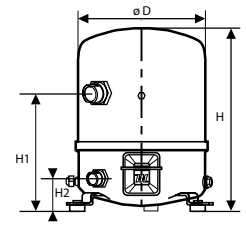

4 cylinders
 D : 352 mm
 H : 519/540 mm
 H1 : 233 mm
 H2 : 125 mm

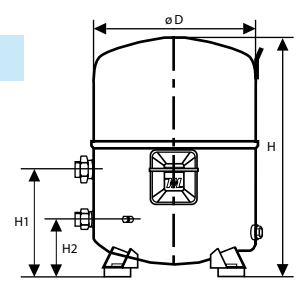

Tandem 2 x 4
 H : 544/565 mm
 D : 515 mm
 W : 925 mm

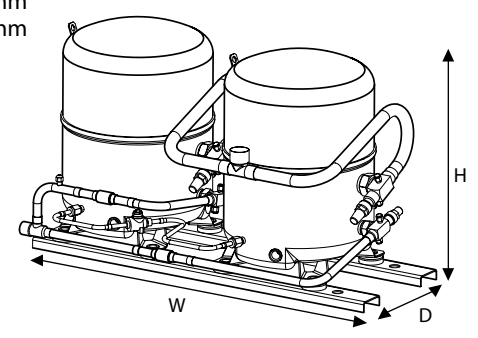



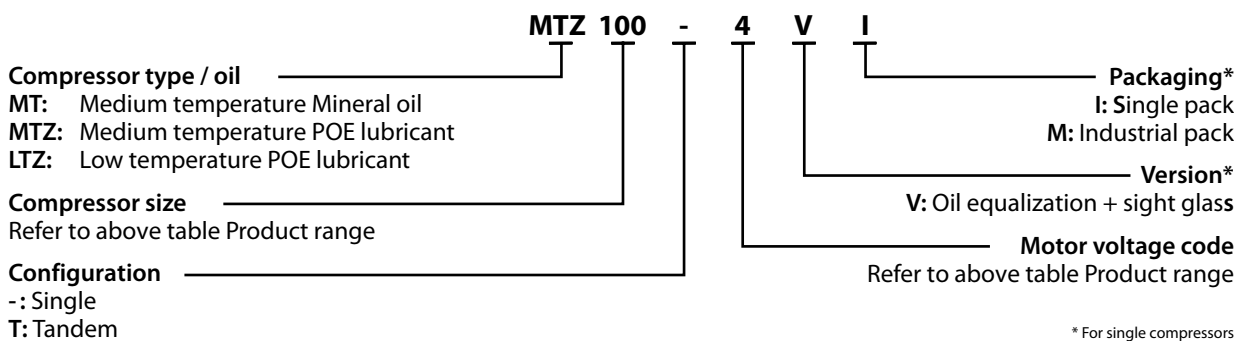

M-HBP: Medium High Back Pressure - LBP: Low Back Pressure
 * CT2 phased out January 2008

CODE NUMBERS FOR ORDERING MT, MTZ, LTZ SERIES



Model	To	-45			-40		-35		-30		-25		-20		-15		-10	
	Tc	Qo	Pe	Qo	Pe	Qo	Pe	Qo	Pe	Qo	Pe	Qo	Pe	Qo	Pe	Qo	Pe	
NTZ048	35	370	0.46	660	0.67	1 140	0.89	1 610	1.10	2 160	1.30	2 800	1.49	3 550	1.64	4 400	1.76	
	45	190	0.35	420	0.59	710	0.84	1 240	1.09	1 700	1.34	2 240	1.57	2 860	1.79	3 570	1.99	
	55	-	-	-	-	430	0.73	700	1.01	1 030	1.30	1 660	1.59	2 160	1.87	2 720	2.13	
NTZ068	35	790	1.04	1 220	1.26	1 980	1.48	2 670	1.71	3 480	1.94	4 430	2.18	5 520	2.43	6 780	2.70	
	45	520	1.02	870	1.28	1 290	1.54	2 110	1.81	2 785	2.09	3 570	2.38	4 490	2.68	5 540	2.99	
	55	-	-	-	-	900	1.58	1 300	1.90	1 790	2.23	2 800	2.57	3 540	2.93	4 390	3.30	
NTZ096	35	-	-	1 400	1.43	2 310	1.77	3 190	2.12	4 290	2.47	5 620	2.81	7 220	3.15	9 100	3.48	
	45	-	-	910	1.29	1 420	1.67	2 430	2.09	3 360	2.53	4 510	2.99	5 900	3.47	7 550	3.97	
	55	-	-	-	-	820	1.50	1 320	1.95	1 980	2.46	3 320	3.02	4 480	3.61	5 870	4.25	
NTZ108	35	1070	1.32	1 700	1.71	2 820	2.10	3 880	2.47	5 150	2.84	6 650	3.20	8 410	3.55	10 440	3.88	
	45	-	-	1 120	1.57	1 770	2.03	3 010	2.49	4 080	2.95	5 340	3.40	6 80	3.85	8 530	4.29	
	55	-	-	-	-	1 080	1.85	1 710	2.39	2 480	2.94	4 010	3.49	5 200	4.04	6 580	4.60	
NTZ136	35	1 500	1.84	2 260	2.38	3 640	2.91	4 920	3.43	6 450	3.92	8 270	4.39	10 410	4.82	12 880	5.21	
	45	-	-	1 570	2.27	2 360	2.86	3 890	3.47	5 200	4.08	6 750	4.69	8 570	5.29	10 710	5.87	
	55	-	-	-	-	1 540	2.80	2 300	3.47	3 250	4.17	5 200	4.90	6 710	5.64	8 490	6.40	
NTZ215	35	2 220	2.65	3 450	3.40	5 640	4.15	7 620	4.90	9 970	5.60	12 700	6.24	15 860	6.79	19 490	7.23	
	45	1 190	2.31	2 240	3.17	3 540	4.08	5 970	5.01	8 030	5.94	10 440	6.86	13 220	7.72	16 420	8.52	
	55	-	-	-	-	2 050	3.70	3 300	4.81	4 830	5.95	7 860	7.11	10 210	8.26	12 930	9.38	
NTZ271	35	3 240	3.75	4 850	4.64	7 750	5.54	10 380	6.44	13 500	7.35	17 170	8.25	21 420	9.16	26 320	10.05	
	45	2 120	3.57	3 470	4.61	5 140	5.66	8 380	6.73	11 050	7.81	14 190	8.90	17 840	10.00	22 040	11.10	
	55	-	-	-	-	3 390	5.58	4 980	6.82	6 940	8.09	10 950	9.38	13 940	10.69	17 410	12.02	
NTZ430	35	4 430	5.30	6 910	6.80	11 270	8.31	15 250	9.79	19 930	11.19	25 400	12.47	31 730	13.58	38 970	14.47	
	45	2 370	4.61	4 480	6.33	7 080	8.15	11 930	10.02	16 060	11.89	20 880	13.71	26 450	15.44	32 840	17.04	
	55	-	-	-	-	4 090	7.41	6 590	9.61	9 660	11.89	15 720	14.21	20 430	16.52	25 860	18.77	
NTZ542	35	6 480	7.50	9 690	9.28	15 500	11.08	20 760	12.89	27 000	14.70	34 330	16.51	42 840	18.31	52 630	20.10	
	45	4 240	7.14	6 940	9.21	10 290	11.32	16 760	13.46	22 110	15.62	28 380	17.80	35 670	19.99	44 080	22.20	
	55	-	-	-	-	6 780	11.15	9 960	13.64	13 890	16.18	21 900	18.76	27 880	21.38	34 810	24.03	

Legend: **To:** Evaporating temperature in °C **Qo:** Cooling capacity in W  Superheat = 10K  Suction temp. = 20°C
Tc: Condensing temperature in °C **Pe:** Power input in kW  Subcooling = 0 K  Subcooling = 0 K
 NTZ series are drop-in replacement for LTZ series



Scroll compressors

Scroll compressors perfectly suit applications like:

- Water chillers
- Self-contained air conditioning units
- Split systems
- Central air handling units
- Heat pumps
- Residential air conditioning

The complete solution for air-conditioning applications

Designed for excellence in performance, silence and endurance, Danfoss Scroll Compressors are the quietest, most reliable and longest-lasting compressors you can get. Available in a full range of capacities from 2,5 to 30 hp, they provide the perfect fit for any application, from light commercial to large commercial applications, and help you handle even the toughest challenges in the HVAC&R industry.

There is no contact between the scroll flanks in a Performer scroll compressor. The ultra-precise scroll profiles, with controlled orbit, roll and slide on an oil film without friction or wear. Floating tip seals ensure axial sealing with low friction losses. With these techniques, built into an optimised upper shell design, the Scroll compressor combines high energy efficiency with low sound and vibration characteristics.

Danfoss Scroll Compressors are available in a large variety of single and tandem models for R407C, R134a, R410A and R22 refrigerants.

Product advantages	Customer benefits
<ul style="list-style-type: none"> · Simple, lightweight and compact construction for easy assembly · Lowest sound level in HVAC&R industry · Optimised for easy integration and servicing in existing systems · Minimised friction and wear · Optimised upper shell design · 100% suction gas cooled and shielded motor · Large oil reserve · Large internal free volume · Large refrigerant charge capacity 	<ul style="list-style-type: none"> · Easy to install and service · Silent operation · Low energy consumption · Long lifetime · Low running costs · High thermal working conditions · Constant performance

Dimensions

R22	R407C	R410A	D	H	H1	H2
HRM032	HRP038	HRH031	165	420	257	386
HRM034	HRP040	HRH032				
HRM040	HRP042	HRH034				
HRM042		HRH036				
HRM045	HRP045	HRH038	165	446	282	412
HRM047	HRP047	HRH040				
HRM048	HRP048	HRH041	184	462	287	429
HRM051	HRP051	HRH044				
HRM054	HRP054	HRH049				
HRM058	HRP058	HRH051				
HRM060	HRP060	HRH054				
HLM068	HLP068	HRH056				
HLM072	HLP072	HLH068				
HLM075	HLP075	HLJ072				
HLM078	HLP081	HLJ083				
HLM081						

All dimensions in mm

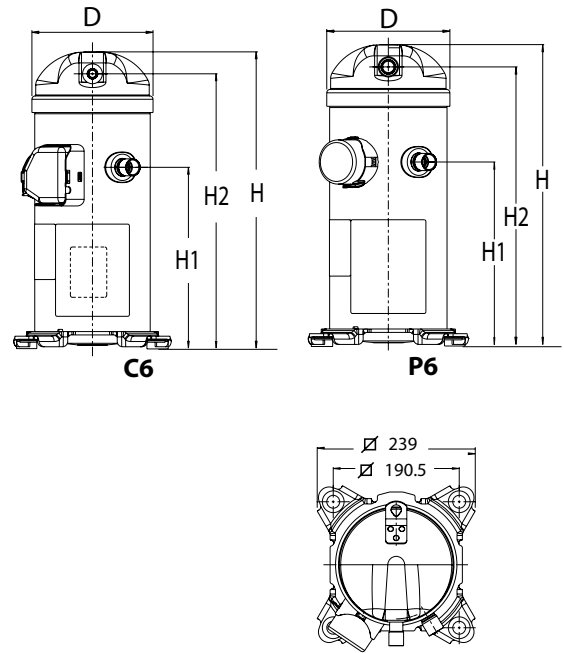

R22	R407C	D	H	H1	H2
HCM094	HCP094	184	539	372	512
HCM109	HCP109	184	548	372	522
HCM120	HCP120				

All dimensions in mm

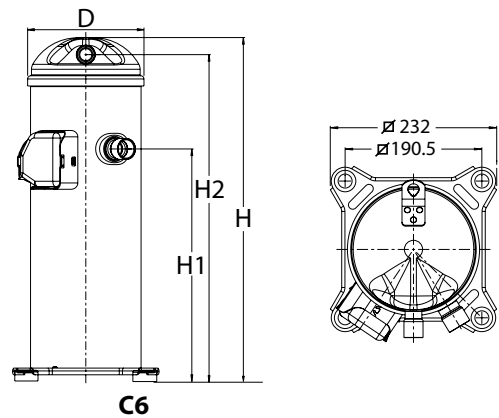

Please check with Danfoss for availability of C6 / P6 and other features.

Type	Size	Motor	Features
HRH	036	U1L	P6

Application: _____
H: high temperature / air conditioning

Family: _____
C: light commercial scroll
R: residential scroll (new platform)
L: light commercial scroll (new platform)

Refrigerant & lubricant: _____
M: R22, mineral or alkylbenzene oil
P: R407C, POE lubricant
H: R410A, POE lubricant
J: R410A, PVE lubricant

Nominal capacity: _____
 In thousand Btu/h at 60 Hz,
 ARI conditions

Model variation _____
T: design optimized for 7.2/54.4 (45/130)
U: design optimized for 7.2/37.8 (45/100)

Other features

	Oil sight glass	Oil equalisation	Oil drain	LP gauge port
2	None	None	None	Schrader
6	None	None	None	None
7	Threaded	None	None	None
8	None	Brazed	None	None

Tubing and electrical connections
P: brazed connections, spade terminals
C: brazed connections, screw terminals

Motor protection
L: internal motor protection

Motor voltage code
1: 208-230V/1~/60 Hz
2: 208-230V/3~/60 Hz
4: 380-400V/3~/50 Hz & 460V/3~/60 Hz
5: 220-240V/1~/50 Hz & 265V/1~/60 Hz
7: 500V/3~/50 Hz & 575V/ 3~/60 Hz
9: 380V/3~/60 Hz

	Model	To	-25		-20		-15		-10		-5		0		5		10	
		Tc	Qo	Pe	Qo	Pe	Qo	Pe	Qo	Pe	Qo	Pe	Qo	Pe	Qo	Pe	Qo	Pe
RESIDENTIAL SCROLL	HRP034T5 120U2019*	35	2 341	1,85	3 119	1.82	4 019	1,79	5 066	1,78	6 289	1,77	7 717	1,75	9 375	1,71	11 292	1,66
		45	-	-	2 714	2,29	3 536	2,26	4 494	2,24	5 614	2,22	6 925	2,20	8 455	2,18	10 230	2,13
		55	-	-	-	-	-	-	3 850	2,88	4 848	2,85	6 025	2,82	7 407	2,78	9 022	2,73
	HRP040T5 120U1929*	35	2 524	2,138	3 369	2,097	4 346	2,072	5 484	2,06	6 815	2,04	8 370	2,02	10 181	1,98	12 278	1,92
		45	-	-	2 879	2,654	3 761	2,617	4 787	2,59	5 989	2,57	7 398	2,55	9 043	2,56	10 956	2,46
		55	-	-	-	-	-	-	4 014	3,34	5 066	3,30	6 306	3,26	7 765	3,22	9 473	3,16
	HRP047T5 120U0986*	35	3 029	2,468	4 051	2,419	5 227	2,390	6 595	2,37	8 196	2,36	10 066	2,33	12 245	2,28	14 771	2,214
		45	-	-	3 424	3,082	4 485	3,038	5 714	3,01	7 149	2,99	8 829	2,96	10 792	2,92	13 077	2,86
		55	-	-	-	-	-	-	4 746	3,90	5 994	3,86	7 462	3,82	9 187	3,77	11 208	3,70
	HRP060T5 120U1606*	35	3 754	2,999	5 006	2,940	6 455	2,905	8 147	2,88	10 125	2,86	12 435	2,83	15 123	2,78	18 234	2,69
45		-	-	4 310	3,740	5 620	3,686	7 150	3,65	8 944	3,62	11 047	3,59	13 504	3,54	16 361	3,47	
55		-	-	-	-	-	-	6 034	4,73	7 611	4,67	9 473	4,62	11 666	4,56	14 232	4,47	
HRP034T4 120U2024	35	2 480	1,73	3 190	1,71	4 050	1,70	5 080	1,69	6 290	1,68	7 710	1,67	9 340	1,64	11 220	1,59	
	45	-	-	2 770	2,19	3 550	2,17	4 470	2,16	5 560	2,15	6 830	2,14	8 310	2,11	10 010	2,08	
	55	-	-	-	-	-	-	3 790	2,77	4 760	2,76	5 900	2,75	7 220	2,73	8 740	2,71	
HRP040T4 120U1016	35	2 850	2,02	3 670	2,01	4 660	2,00	5 840	1,99	7 230	1,97	8 860	1,95	10 740	1,92	12 890	1,87	
	45	-	-	3 180	2,57	4 070	2,55	5 130	2,54	6 380	2,52	7 850	2,51	9 540	2,48	11 500	2,44	
	55	-	-	-	-	-	-	4 350	3,24	5 460	3,23	6 770	3,22	8 290	3,20	10 040	3,17	
HRP047T4 120U1046	35	3 440	2,30	4 410	2,28	5 600	2,26	7 020	2,25	8 690	2,24	10 650	2,22	12 910	2,18	15 500	2,12	
	45	-	-	3 870	2,97	4 940	2,94	6 220	2,93	7 740	2,91	9 510	2,89	11 570	2,86	13 930	2,81	
	55	-	-	-	-	-	-	5 320	3,81	6 680	3,80	8 280	3,78	10 130	3,76	12 270	3,73	
HRP054T4 120U1691	35	3 920	2,44	5 020	2,46	6 350	2,50	7 950	2,53	9 850	2,57	12 070	2,61	14 640	2,66	17 580	2,71	
	45	-	-	4 380	3,32	5 590	3,29	7 030	3,26	8 750	3,25	10 760	3,24	13 090	3,24	15 770	3,25	
	55	-	-	-	-	-	-	6 060	4,15	7 570	4,10	9 360	4,06	11 440	4,03	13 840	4,01	
HRP060T4 120U1726	35	4 350	2,71	5 560	2,74	7 040	2,78	8 820	2,81	10 920	2,85	13 380	2,90	16 230	2,95	19 490	3,02	
	45	-	-	4 850	3,65	6 180	3,61	7 780	3,58	9 670	3,55	11 890	3,54	14 470	3,54	17 440	3,56	
	55	-	-	-	-	-	-	6 690	4,50	8 360	4,42	10 320	4,36	12 610	4,32	15 260	4,30	
LIGHT COMMERCIAL SCROLL	HLP072T4 120U1756	35	5 160	3,16	6 590	3,19	8 350	3,23	10 470	3,28	12 970	3,33	15 890	3,38	19 270	3,45	23 130	3,52
		45	-	-	5 780	4,30	7 390	4,27	9 320	4,24	11 600	4,22	14 270	4,21	17 360	4,21	20 900	4,23
		55	-	-	-	-	-	-	8 060	5,40	10 110	5,33	12 520	5,28	15 310	5,24	18 520	5,22
	HLP081T4 120U1781	35	5 690	3,93	7 300	3,91	9 260	3,89	11 610	3,87	14 380	3,85	17 620	3,81	21 350	3,75	25 630	3,65
		45	-	-	6 440	4,80	8 210	4,78	10 340	4,76	12 860	4,74	15 810	4,71	19 230	4,66	23 150	4,58
		55	-	-	-	-	-	-	8 900	5,83	11 170	5,81	13 830	5,79	16 940	5,76	20 510	5,70
	HCP094T4 120U0601	35	6 600	4,61	8 480	4,59	10 760	4,57	13 480	4,55	16 700	4,52	20 450	4,47	24 790	4,40	29 760	4,29
		45	-	-	7 470	5,63	9 530	5,60	12 000	5,58	14 920	5,56	18 350	5,52	22 320	5,46	26 880	5,37
		55	-	-	-	-	-	-	10 330	6,82	12 960	6,81	16 050	6,78	19 650	6,74	23 810	6,68
	HCP109T4 120U0376	35	7 710	5,83	9 900	5,81	12 570	5,80	15 750	5,77	19 510	5,73	23 890	5,67	28 960	5,58	34 770	5,45
		45	-	-	8 700	6,86	11 100	6,85	13 980	6,83	17 390	6,80	21 380	6,75	26 000	6,68	31 310	6,57
		55	-	-	-	-	-	-	11 990	7,97	15 050	7,96	18 640	7,93	22 820	7,88	27 650	7,79
	HCP120T4 120U0401	35	8 420	6,36	10 810	6,35	13 720	6,33	17 190	6,30	21 300	6,26	26 090	6,19	31 620	6,09	37 960	5,95
		45	-	-	9 500	7,48	12 120	7,47	15 260	7,45	18 980	7,42	23 340	7,37	28 380	7,29	34 180	7,17
		55	-	-	-	-	-	-	13 090	8,69	16 430	8,68	20 350	8,65	24 920	8,59	30 180	8,50

To: Evaporating temperature in °C
Tc: Condensing temperature in °C

Qo: Cooling capacity in W
Pe: Power input in kW

Superheat = 11.1 K
Subcooling = 8.3 K

Voltage: 400 V / 3 / 50 Hz
*: Voltage: 220-240 V / 1 / 50 Hz

These code numbers are normally on stock at our Partner, Wholesaler or have a short lead-time.

Full Danfoss A/C scroll compressor line-up

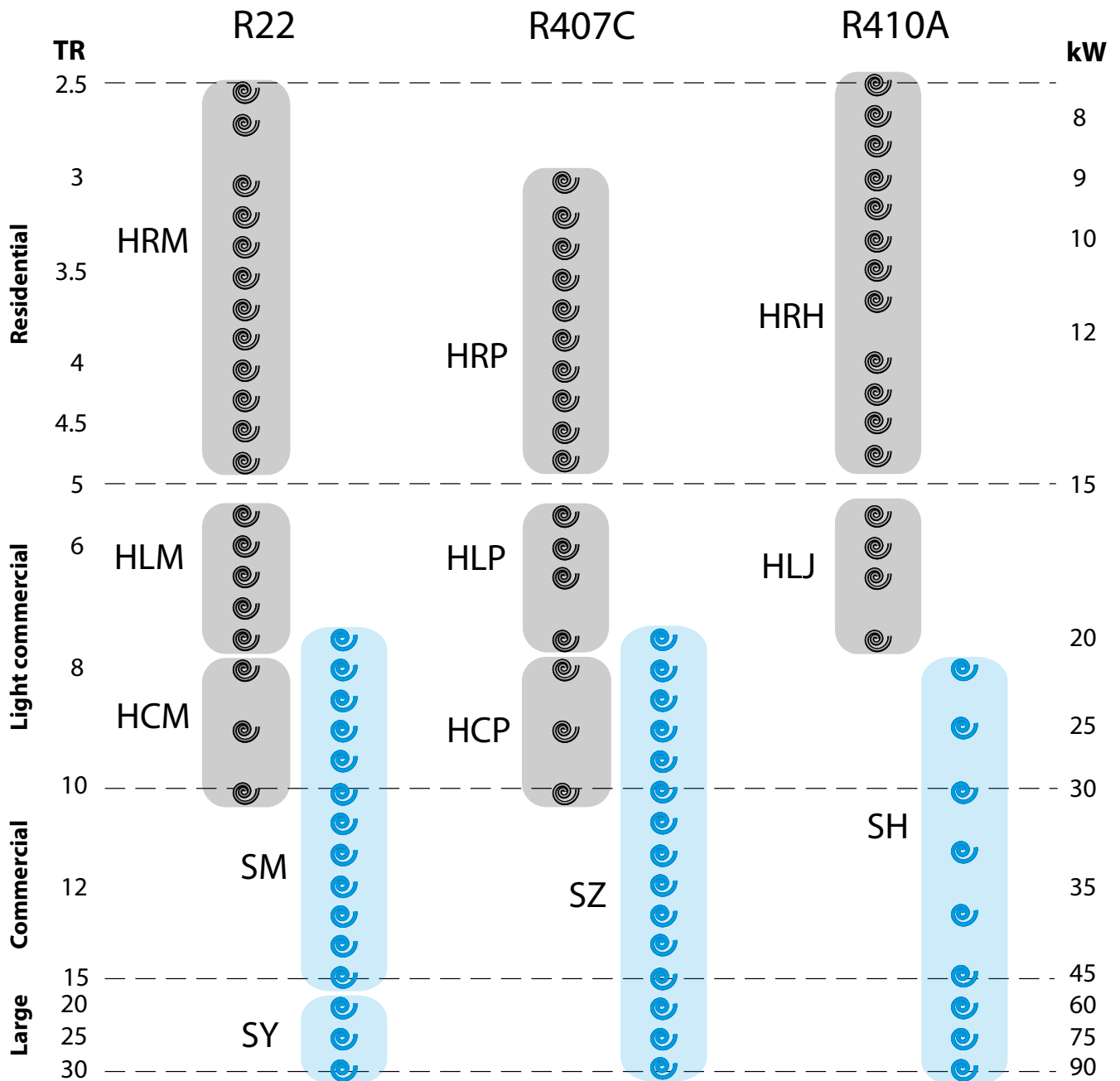

Product range single compressors

	D	H	H1	H2
S084 S090 S100	254	508	142	465
S110 S120	254	558	178	515
S148 S161	266	591	180	556

All dimensions in mm

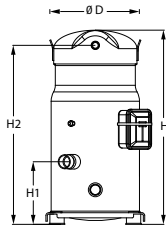

	D	H	H1	H2
S115 S125	254	586	180	538
S160	266	631	180	596
S175 S185	316	678	180	641

All dimensions in mm

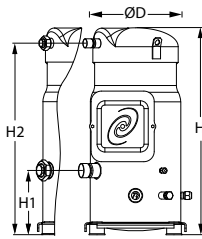

	D	H	H1	H2
S240	344	729	196	656
S300	344	740	196	667
S380	344	770	203	695

All dimensions in mm

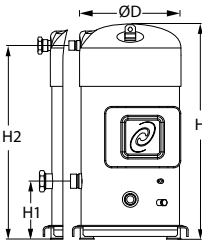

Model	Nominal voltage				
	200-230/ 3/60	400/3/50 460/3/60	230/3/50	500/3/50 575/3/60	380/3/60
	Motor voltage code				
	3	4	6	7	9
SM/SZ084					
SM/SZ090					
SM/SZ100					
SM/SZ110					
SM/SZ115					
SM/SZ120					
SM/SZ125					
SM/SZ148					
SM/SZ160					
SM/SZ161					
SM/SZ175					
SM/SZ185					
SY/SZ240					
SY/SZ300					
SY/SZ380 *					

* SY380 only available for 400/3/50Hz Rotolock version Brazed version

Family, lubricant & refrigerant	Nominal capacity	Voltage	Version	Packaging
SZ SY	185 300	- A	4 9	R AA I M

lubricant
 I, Mineral oil, 22
 I, POE lubricant, 22
 I, POE lubricant, 107C - R134a

capacity
 Ind Btu/h
 R22,
 itions

voltage code
 Above table

Packaging
 I: Individual
 M: Multiple

Motor protection type	Version			Applies to		
Internal overload protector	V VA	V V	Brazed Brazed	A	Evolution index	S 084 - 090 - 100 - 110 - 120 - 148 - 161
Internal thermostat, external overload protector required	C	C	Brazed	A	Evolution index	S 115 - 125 - 160 - 175 - 185
	CA	C	Brazed	A	Evolution index	
	R RA	R R	Rotolock Rotolock	A A	Evolution index	
Electronic protection module	AA	A	Brazed	A	24 V	S 240 - 300 S 380 (no rotolock)
	AB	A	Brazed	B	115/230 V	
	MA	M	Rotolock	A	24 V	
	MB	M	Rotolock	B	115/230 V	

SM / SY R22

Performance data

Model	To	-20		-15		-10		-5		0		5		10		15	
	Tc	Qo	Pe	Qo	Pe	Qo	Pe	Qo	Pe	Qo	Pe	Qo	Pe	Qo	Pe	Qo	Pe
SM084	35 55	7 700 -	4.0 -	9 900 -	4.0 -	12 500 -	4.0 -	15 500 12 000	4.0 6.4	18 900 15 000	4.0 6.3	22 800 18 500	4.0 6.2	27 200 22 500	3.9 6.2	32 100 26 900	3.9 6.1
SM090	35 55	8 600 -	4.3 -	10 900 -	4.4 -	13 600 -	4.4 -	16 700 13 300	4.4 6.7	20 200 16 400	4.4 6.7	24 300 19 900	4.4 6.6	28 900 23 900	4.4 6.6	34 100 28 400	4.4 6.5
SM100	35 55	9 000 -	4.6 -	11 500 -	4.6 -	14 400 -	4.7 -	17 700 14 200	4.7 7.1	21 500 17 400	4.7 7.1	25 800 21 200	4.7 7.1	30 700 25 400	4.7 7.0	36 200 30 200	4.7 7.0
SM110	35 55	10 200 -	5.2 -	13 000 -	5.2 -	16 200 -	5.2 -	20 000 15 900	5.2 8.0	24 200 19 600	5.2 8.0	29 000 23 800	5.2 7.9	34 400 28 400	5.2 7.9	40 400 33 700	5.2 7.8
SM115	35 55	11 200 -	5.4 -	13 900 -	5.4 -	17 100 -	5.4 -	20 800 16 500	5.5 8.6	25 100 20 700	5.5 8.5	30 000 25 500	5.4 8.5	35 600 31 000	5.4 8.4	41 800 37 100	5.4 8.3
SM120	35 55	11 800 -	6.0 -	15 200 -	6.0 -	19 000 -	6.0 -	23 300 18 600	5.9 9.2	28 200 22 800	5.9 9.2	33 700 27 600	5.9 9.1	39 900 33 000	5.9 9.0	46 700 38 900	5.9 9.0
SM125	35 55	12 000 -	5.8 -	15 000 -	5.8 -	18 400 -	5.9 -	22 400 17 700	5.9 9.3	27 000 22 300	5.9 9.2	32 300 27 400	5.9 9.1	38 200 33 300	5.8 9.0	45 000 39 900	5.8 8.9
SM148	35 55	14 800 -	7.0 -	18 500 -	7.0 -	22 900 -	7.1 -	27 800 22 600	7.1 10.9	33 600 27 500	7.2 10.9	40 100 33 100	7.2 10.9	47 500 39 500	7.3 11.0	55 900 46 800	7.3 11.0
SM160	35 55	15 500 -	7.6 -	19 600 -	7.7 -	24 300 -	7.8 -	29 700 24 100	7.9 11.6	35 900 29 600	8.0 11.6	43 000 35 800	8.1 11.7	50 900 42 900	8.1 11.8	59 800 50 800	8.2 11.8
SM161	35 55	16 000 -	7.5 -	20 100 -	7.6 -	24 700 -	7.6 -	30 100 24 400	7.6 11.7	36 300 29 700	7.7 11.7	43 400 35 800	7.7 11.7	51 400 42 800	7.8 11.8	60 500 50 600	7.8 11.8
SM175	35 55	17 000 -	8.1 -	21 300 -	8.1 -	26 400 -	8.2 -	32 300 26 200	8.3 12.4	39 000 32 000	8.4 12.5	46 600 38 500	8.4 12.6	55 200 46 000	8.5 12.6	64 800 54 400	8.5 12.7
SM185	35 55	18 400 -	8.8 -	23 100 -	8.9 -	28 600 -	9.0 -	35 000 28 400	9.1 13.6	42 200 34 600	9.1 13.7	50 500 41 800	9.2 13.8	59 800 49 800	9.3 13.8	70 200 58 900	9.3 13.9
SY240	35 55	25 100 -	11.7 -	31 400 -	11.8 -	38 800 -	12.0 -	47 300 38 400	12.1 17.8	57 100 46 600	12.4 18.0	68 300 56 100	12.6 18.3	81 000 67 000	13.0 18.6	95 300 79 300	13.3 18.9
SY300	35 55	31 900 -	14.2 -	39 900 -	14.5 -	49 300 -	14.8 -	60 300 48 600	15.1 22.0	73 100 59 200	15.6 22.4	87 900 71 600	16.1 22.8	104 800 85 900	16.7 23.4	124 100 102 300	17.4 24.1
SY380	35 55	40 100 -	17.3 -	49 500 -	17.6 -	60 500 -	18.0 -	73 300 59 700	18.4 26.8	88 100 72 300	18.8 27.1	104 900 86 800	19.2 27.5	124 100 103 400	19.8 27.9	145 800 122 300	20.4 28.4
SM170	35 55	15 200 -	8.0 -	19 500 -	8.0 -	24 600 -	8.0 -	30 500 23 600	8.0 12.7	37 200 29 600	8.0 12.6	44 900 36 500	7.9 12.5	53 500 44 300	7.9 12.3	63 200 53 100	7.8 12.1
SM180	35 55	16 900 -	8.6 -	21 400 -	8.7 -	26 700 -	8.8 -	32 800 26 200	8.8 13.4	39 900 32 300	8.8 13.3	47 900 39 300	8.8 13.3	56 900 47 100	8.8 13.2	67 100 56 000	8.7 13.1
SM200	35 55	17 700 -	9.2 -	22 600 -	9.3 -	28 300 -	9.3 -	34 800 27 900	9.3 14.3	42 300 34 400	9.4 14.2	50 900 41 700	9.4 14.1	60 500 50 000	9.4 14.0	71 300 59 400	9.4 13.9
SM220	35 55	20 000 -	10.4 -	25 500 -	10.4 -	32 000 -	10.4 -	39 300 31 400	10.4 16.0	47 700 38 600	10.5 16.0	57 100 46 800	10.5 15.9	67 700 56 000	10.4 15.8	79 500 66 300	10.4 15.6
SM230	35 55	22 000 -	10.8 -	27 400 -	10.9 -	33 700 -	10.9 -	41 000 32 500	10.9 17.2	49 500 40 800	10.9 17.1	59 100 50 200	10.9 16.9	70 100 61 000	10.9 16.7	82 400 73 100	10.8 16.5
SM242	35 55	23 300 -	12.0 -	29 900 -	11.9 -	37 400 -	11.9 -	45 900 36 600	11.9 18.4	55 600 45 000	11.9 18.3	66 400 54 400	11.9 18.2	78 500 64 900	11.8 18.1	92 000 76 600	11.8 17.9
SM250	35 55	23 700 -	11.6 -	29 500 -	11.7 -	36 200 -	11.7 -	44 100 35 000	11.7 18.5	53 200 43 800	11.7 18.4	63 500 54 000	11.7 18.2	75 300 65 600	11.7 18.0	88 600 78 600	11.6 17.7
SM268	35 55	26 300 -	13.0 -	33 200 -	13.0 -	41 200 -	13.0 -	50 400 40 500	13.1 20.1	60 800 49 600	13.1 20.1	72 700 59 800	13.2 20.0	86 000 71 400	13.2 20.0	101 000 84 400	13.2 20.0
SM271	35 55	25 800 -	12.7 -	32 500 -	12.8 -	40 300 -	12.8 -	49 300 39 700	12.9 19.7	59 600 48 600	12.9 19.7	71 300 58 700	13.0 19.7	84 500 70 100	13.0 19.6	99 300 83 000	13.0 19.6
SM281	35 55	27 500 -	13.5 -	34 700 -	13.5 -	43 000 -	13.6 -	52 600 42 300	13.6 20.9	63 600 51 800	13.6 20.9	75 900 62 500	13.7 20.8	89 900 74 600	13.7 20.8	105 500 88 200	13.7 20.8
SM285	35 55	27 100 -	13.4 -	34 000 -	13.5 -	42 100 -	13.6 -	51 400 41 200	13.7 20.8	62 000 51 100	13.8 20.8	74 100 62 300	13.9 20.8	87 800 75 000	14.0 20.8	103 200 89 300	14.1 20.7
SM290	35 55	27 700 -	13.5 -	34 700 -	13.6 -	42 900 -	13.7 -	52 300 42 000	13.8 21.0	63 100 51 900	13.8 21.1	75 400 63 100	13.9 21.1	89 400 75 800	13.9 21.0	105 100 90 100	13.9 20.9
SM296	35 55	29 200 -	14.0 -	36 500 -	14.1 -	45 000 -	14.2 -	54 800 44 500	14.2 21.8	66 100 54 100	14.3 21.8	79 000 65 200	14.4 21.8	93 600 77 900	14.5 21.9	110 100 92 200	14.6 21.9
SM310	35 55	30 000 -	14.6 -	37 500 -	14.7 -	46 300 -	14.8 -	56 500 45 400	14.9 22.8	68 200 56 000	15.0 22.9	81 500 68 100	15.1 22.9	96 500 81 900	15.1 22.8	113 500 97 300	15.1 22.7
SM320	35 55	30 600 -	15.2 -	38 600 -	15.4 -	47 900 -	15.6 -	58 600 47 400	15.7 23.1	70 800 58 300	15.9 23.3	84 700 70 600	16.1 23.4	100 300 84 500	16.3 23.5	117 900 100 100	16.5 23.7
SM322	35 55	31 600 -	15.0 -	39 500 -	15.1 -	48 700 -	15.2 -	59 300 48 100	15.3 23.4	71 500 58 600	15.4 23.4	85 500 70 600	15.5 23.4	101 300 84 200	15.6 23.5	119 100 99 700	15.6 23.5
SM350	35 55	33 500 -	16.1 -	42 000 -	16.3 -	52 000 -	16.4 -	63 600 51 600	16.6 24.9	76 800 63 000	16.7 25.0	91 800 75 900	16.8 25.2	108 700 90 600	16.9 25.3	127 700 107 100	17.0 25.4
SM370	35 55	36 200 -	17.6 -	45 500 -	17.8 -	56 400 -	18.0 -	68 900 55 900	18.1 27.2	83 200 68 200	18.3 27.3	99 400 82 300	18.4 27.5	117 700 98 200	18.5 27.6	138 300 116 000	18.6 27.7
SY482	35 55	49 500 -	23.3 -	61 900 -	23.6 -	76 400 -	23.9 -	93 200 75 600	24.3 35.6	112 500 91 900	24.7 36.1	134 500 110 600	25.2 36.6	159 500 131 900	25.9 37.1	187 700 156 100	26.6 37.8
SY540	35 55	56 200 -	25.9 -	70 200 -	26.3 -	86 700 -	26.7 -	106 000 85 600	27.3 39.8	128 300 104 300	27.9 40.4	153 800 125 900	28.7 41.1	183 000 150 600	29.6 42.0	216 000 178 800	30.7 43.0
SY600	35 55	62 900 -	28.5 -	78 600 -	28.9 -	97 100 -	29.5 -	118 800 95 700	30.2 43.9	144 100 116 700	31.1 44.7	173 200 141 100	32.2 45.7	206 500 169 300	33.4 46.8	244 400 201 500	34.8 48.1
SY620	35 55	64 200 -	29.0 -	79 700 -	29.5 -	97 800 -	29.9 -	118 800 96 600	30.5 44.6	143 000 117 200	31.1 45.1	170 600 140 800	31.9 45.7	202 000 167 800	32.7 46.5	237 400 198 500	33.7 47.3
SY680	35 55	70 900 -	31.6 -	88 100 -	32.1 -	108 200 -	32.7 -	131 600 106 600	33.5 48.7	158 800 129 600	34.3 49.4	189 900 156 100	35.3 50.3	225 500 186 500	36.5 51.3	265 800 221 200	37.8 52.5
SY760	35 55	79 000 -	34.7 -	97 600 -	35.3 -	119 300 -	35.9 -	144 500 117 600	36.7 53.5	173 500 142 500	37.5 54.1	206 700 171 000	38.5 54.9	244 400 203 700	39.5 55.8	287 100 240 900	40.7 56.8

Legend: To: Evaporating temperature in °C
Tc: Condensing temperature in °C

Qo: Cooling capacity in W
Pe: Power input in kW

Superheat = 11.1 K
Subcooling = 8.3 K

Voltage: 400 V / 3 / 50 Hz

SZ R134a

Performance data

Model	To	-15		-10		-5		0		5		10		15	
	Tc	Qo	Pe	Qo	Pe	Qo	Pe	Qo	Pe	Qo	Pe	Qo	Pe	Qo	Pe
SZ084	35	6 200	2.8	8 000	2.8	10 100	2.8	12 600	2.8	15 400	2.7	18 700	2.7	22 400	2.6
	55	-	-	6 100	4.3	7 900	4.3	9 900	4.3	12 400	4.3	15 100	4.3	18 300	4.2
SZ090	35	6 700	2.9	8 600	2.9	10 900	3.0	13 400	2.9	16 400	2.9	19 800	2.9	23 600	2.8
	55	-	-	6 600	4.5	8 500	4.6	10 700	4.6	13 200	4.6	16 000	4.5	19 300	4.5
SZ100	35	7 300	3.1	9 400	3.1	11 700	3.1	14 400	3.1	17 500	3.1	21 000	3.1	25 000	3.1
	55	-	-	7 300	4.8	9 300	4.8	11 500	4.9	14 100	4.9	17 100	4.9	20 400	4.8
SZ110	35	8 200	3.5	10 500	3.5	13 200	3.5	16 200	3.5	19 800	3.5	23 800	3.5	28 400	3.5
	55	-	-	8 100	5.4	10 400	5.4	13 000	5.5	16 000	5.5	19 400	5.5	23 300	5.4
SZ115	35	9 000	3.8	11 600	3.8	14 500	3.8	17 900	3.8	21 800	3.8	26 300	3.7	31 200	3.7
	55	-	-	8 900	5.9	11 400	5.9	14 300	5.9	17 600	5.9	21 400	5.9	25 700	5.9
SZ120	35	9 400	4.0	12 000	4.0	15 100	4.1	18 700	4.1	22 800	4.1	27 500	4.1	32 900	4.0
	55	-	-	9 300	6.2	11 900	6.3	14 900	6.3	18 400	6.3	22 400	6.3	27 000	6.2
SZ125	35	9 600	4.1	12 300	4.1	15 500	4.1	19 100	4.1	23 300	4.0	28 000	4.0	33 300	3.9
	55	-	-	9 500	6.3	12 100	6.3	15 200	6.3	18 800	6.3	22 800	6.3	27 400	6.2
SZ148	35	11 200	5.0	14 400	5.0	18 100	5.0	22 600	5.0	27 900	5.0	34 000	5.0	41 100	5.0
	55	-	-	11 200	7.7	14 200	7.7	17 800	7.7	22 100	7.7	27 100	7.8	32 800	7.8
SZ160	35	12 400	5.3	15 900	5.3	20 000	5.4	24 700	5.4	30 200	5.4	36 400	5.4	43 500	5.4
	55	-	-	12 300	7.9	15 800	8.0	19 800	8.0	24 500	8.1	29 800	8.1	35 900	8.1
SZ161	35	12 000	5.2	15 300	5.2	19 200	5.3	23 800	5.3	29 200	5.4	35 500	5.4	42 700	5.4
	55	-	-	12 100	8.0	15 300	8.0	19 200	8.1	23 700	8.1	28 900	8.1	35 000	8.1
SZ175	35	13 200	5.7	16 900	5.8	21 200	5.8	26 200	5.9	32 100	5.9	38 700	5.9	46 200	5.8
	55	-	-	13 100	8.6	16 700	8.6	21 000	8.7	26 000	8.7	31 700	8.8	38 100	8.8
SZ185	35	14 000	6.1	18 000	6.1	22 600	6.2	27 900	6.2	34 100	6.3	41 200	6.3	49 200	6.2
	55	-	-	13 900	9.1	17 800	9.2	22 400	9.3	27 700	9.3	33 700	9.3	40 600	9.3
SZ240	35	18 900	8.4	23 900	8.5	29 900	8.6	37 100	8.7	45 700	8.7	56 000	8.8	68 200	8.9
	55	-	-	18 800	12.3	23 800	12.5	29 700	12.6	36 700	12.7	45 000	12.8	54 700	13.0
SZ300	35	23 700	10.2	30 000	10.4	37 500	10.5	46 300	10.6	56 700	10.7	68 900	10.8	82 800	11.0
	55	-	-	23 600	15.2	29 700	15.4	37 100	15.6	45 800	15.9	55 900	16.1	67 800	16.4
SZ170	35	12 200	5.5	15 700	5.6	19 900	5.6	24 800	5.5	30 400	5.5	36 800	5.4	44 000	5.3
	55	-	-	11 900	8.6	15 500	8.6	19 600	8.6	24 300	8.6	29 800	8.5	36 000	8.4
SZ180	35	13 300	5.9	17 000	5.9	21 400	5.9	26 500	5.9	32 300	5.8	39 000	5.8	46 500	5.7
	55	-	-	13 100	9.1	16 800	9.1	21 100	9.1	26 000	9.1	31 600	9.1	38 000	9.0
SZ200	35	14 500	6.2	18 400	6.2	23 000	6.3	28 400	6.3	34 500	6.2	41 400	6.2	49 200	6.1
	55	-	-	14 400	9.6	18 200	9.7	22 700	9.7	27 800	9.7	33 600	9.7	40 200	9.7
SZ220	35	16 300	7.0	20 700	7.0	25 900	7.1	32 000	7.1	39 000	7.1	46 900	7.0	56 000	6.9
	55	-	-	16 100	10.8	20 500	10.9	25 600	10.9	31 400	10.9	38 200	10.9	45 900	10.9
SZ230	35	17 800	7.6	22 800	7.6	28 600	7.6	35 300	7.6	43 000	7.6	51 700	7.5	61 600	7.4
	55	-	-	17 500	11.7	22 500	11.8	28 200	11.8	34 800	11.8	42 200	11.8	50 700	11.7
SZ242	35	18 600	8.0	23 700	8.1	29 700	8.1	36 800	8.1	44 900	8.1	54 200	8.1	64 900	8.0
	55	-	-	18 300	12.5	23 400	12.5	29 300	12.5	36 200	12.5	44 200	12.5	53 300	12.4
SZ250	35	19 000	8.1	24 300	8.1	30 500	8.1	37 600	8.1	45 800	8.1	55 100	8.0	65 600	7.9
	55	-	-	18 600	12.5	23 900	12.5	30 000	12.6	37 000	12.6	45 000	12.5	54 000	12.5
SZ268	35	20 300	9.0	26 000	9.1	32 700	9.1	40 700	9.1	49 900	9.1	60 600	9.1	72 900	9.0
	55	-	-	20 100	13.9	25 700	14.0	32 200	14.0	39 900	14.0	48 700	14.0	59 000	14.0
SZ271	35	19 900	8.7	27 800	9.4	34 900	9.4	39 500	8.9	48 300	8.9	58 400	8.9	70 000	8.9
	55	-	-	21 400	14.2	27 500	14.2	31 700	13.5	39 000	13.6	47 600	13.6	57 400	13.6
SZ281	35	21 100	9.2	29 200	10.2	36 800	10.3	41 900	9.4	51 200	9.4	62 100	9.4	74 500	9.4
	55	-	-	22 900	15.7	29 100	15.7	33 500	14.3	41 400	14.4	50 600	14.4	61 100	14.3
SZ285	35	21 700	9.3	27 800	9.4	34 900	9.4	43 100	9.5	52 600	9.5	63 400	9.4	75 600	9.3
	55	-	-	21 400	14.2	27 500	14.2	34 500	14.3	42 600	14.4	51 900	14.4	62 400	14.3
SZ290	35	21 900	9.5	28 000	9.6	35 200	9.6	43 500	9.7	53 100	9.7	64 000	9.6	76 300	9.5
	55	-	-	21 600	14.4	27 700	14.5	34 800	14.6	43 000	14.6	52 300	14.7	62 900	14.6
SZ296	35	22 100	10.0	28 300	10.0	35 700	10.0	44 500	10.0	54 900	10.0	67 000	10.0	80 900	10.0
	55	-	-	22 000	15.4	28 000	15.4	35 200	15.4	43 500	15.5	53 300	15.5	64 700	15.6
SZ310	35	23 300	10.1	29 800	10.2	37 500	10.3	46 300	10.3	56 500	10.3	68 100	10.2	81 200	10.1
	55	-	-	23 000	15.4	29 500	15.5	37 100	15.5	45 800	15.6	55 700	15.6	67 000	15.6
SZ320	35	24 400	10.5	31 300	10.6	39 300	10.7	48 700	10.8	59 400	10.8	71 700	10.8	85 700	10.8
	55	-	-	24 200	15.8	31 000	15.9	39 000	16.0	48 200	16.1	58 700	16.2	70 700	16.2
SZ322	35	23 600	10.4	30 100	10.5	37 800	10.5	46 900	10.6	57 600	10.7	69 900	10.8	84 100	10.8
	55	-	-	23 800	15.9	30 200	16.0	37 800	16.1	46 600	16.2	56 900	16.2	68 900	16.2
SZ350	35	26 000	11.4	33 200	11.5	41 800	11.6	51 700	11.7	63 100	11.8	76 200	11.7	91 100	11.7
	55	-	-	25 700	17.1	33 000	17.3	41 400	17.4	51 200	17.5	62 400	17.5	75 100	17.5
SZ370	35	27 600	12.1	35 400	12.3	44 500	12.4	55 000	12.5	67 200	12.5	81 100	12.5	96 900	12.4
	55	-	-	27 400	18.2	35 100	18.4	44 100	18.5	54 500	18.6	66 400	18.7	79 900	18.6
SZ425	35	32 500	14.5	37 100	12.9	46 600	13.0	64 100	14.9	78 700	15.0	95 700	15.1	115 600	15.1
	55	-	-	28 700	19.9	36 700	20.0	51 300	21.9	63 400	22.1	77 500	22.2	93 900	22.3
SZ482	35	37 300	16.8	47 100	17.0	58 900	17.2	73 100	17.3	90 100	17.5	110 400	17.6	134 300	17.7
	55	-	-	37 100	24.6	46 900	24.9	58 500	25.2	72 300	25.5	88 600	25.7	107 800	26.0
SZ485	35	37 200	16.3	43 800	15.1	54 800	15.2	73 200	16.9	89 500	17.0	108 400	17.1	130 100	17.2
	55	-	-	33 800	23.3	43 200	23.4	58 600	24.9	72 300	25.2	88 300	25.5	106 800	25.8
SZ540	35	42 000	18.6	53 100	18.9	66 400	19.1	82 200	19.3	100 900	19.5	123 000	19.6	148 700	19.8
	55	-	-	41 800	27.5	52 800	27.9	65 800	28.3	81 200	28.6	99 400	29.0	120 700	29.4
SZ600	35	46 800	20.5	59											

SZ R407C

Performance data

Model	To	-20		-15		-10		-5		0		5		10		15	
	Tc	Qo	Pe	Qo	Pe	Qo	Pe	Qo	Pe	Qo	Pe	Qo	Pe	Qo	Pe	Qo	Pe
SZ084	35	7 200	3.9	9 300	3.9	11 800	4.0	14 800	4.0	18 300	4.0	22 300	4.0	27 000	4.0	32 300	3.9
	55	-	-	-	-	-	-	11 300	6.2	14 200	6.2	17 500	6.2	21 400	6.2	25 800	6.2
SZ090	35	7 600	4.1	9 800	4.1	12 500	4.2	15 600	4.2	19 300	4.2	23 600	4.2	28 500	4.2	34 100	4.1
	55	-	-	-	-	-	-	12 000	6.5	15 000	6.5	18 500	6.5	22 500	6.5	27 200	6.5
SZ100	35	8 100	4.3	10 500	4.4	13 300	4.4	16 600	4.4	20 500	4.5	25 000	4.4	30 100	4.4	36 000	4.4
	55	-	-	-	-	-	-	12 700	6.9	15 900	6.9	19 600	6.9	23 800	6.9	28 700	6.9
SZ110	35	9 300	4.9	12 000	5.0	15 200	5.0	19 000	5.0	23 400	5.0	28 500	5.0	34 300	5.0	40 900	4.9
	55	-	-	-	-	-	-	14 500	7.9	18 100	7.9	22 300	7.9	27 200	7.8	32 700	7.8
SZ115	35	10 100	5.4	13 100	5.4	16 600	5.4	20 800	5.5	25 600	5.4	31 100	5.4	37 400	5.4	44 500	5.3
	55	-	-	-	-	-	-	15 800	8.7	19 800	8.7	24 400	8.6	29 600	8.6	35 600	8.5
SZ120	35	11 000	5.7	14 200	5.7	17 900	5.8	22 200	5.8	27 300	5.8	33 200	5.8	39 900	5.7	47 600	5.6
	55	-	-	-	-	-	-	17 000	9.2	21 200	9.2	26 100	9.2	31 600	9.1	38 000	9.0
SZ125	35	10 800	5.7	14 000	5.7	17 700	5.7	22 100	5.7	27 200	5.7	33 100	5.7	39 800	5.7	47 400	5.6
	55	-	-	-	-	-	-	16 800	9.2	21 000	9.1	25 900	9.1	31 500	9.0	37 900	9.0
SZ148	35	13 500	6.9	17 300	7.0	21 700	7.0	27 000	7.0	33 100	7.1	40 300	7.1	48 500	7.1	57 800	7.2
	55	-	-	-	-	-	-	21 200	11.1	26 200	11.1	32 100	11.1	38 900	11.1	46 700	11.1
SZ160	35	14 800	7.3	19 000	7.4	23 900	7.5	29 700	7.6	36 400	7.6	44 300	7.6	53 300	7.6	63 600	7.6
	55	-	-	-	-	-	-	23 200	11.8	28 800	11.9	35 200	11.9	42 700	11.9	51 400	11.9
SZ161	35	14 600	7.4	18 700	7.5	23 500	7.5	29 200	7.6	35 800	7.6	43 500	7.6	52 400	7.7	62 600	7.8
	55	-	-	-	-	-	-	22 900	12.0	28 400	12.0	34 700	12.0	42 100	12.0	50 600	12.0
SZ175	35	15 500	8.0	19 800	8.0	25 000	8.1	31 100	8.2	38 100	8.2	46 300	8.2	55 600	8.2	66 200	8.2
	55	-	-	-	-	-	-	24 000	12.7	29 800	12.8	36 500	12.8	44 200	12.8	53 000	12.8
SZ185	35	16 600	8.6	21 300	8.6	26 900	8.7	33 400	8.8	41 000	8.8	49 700	8.8	59 700	8.8	71 900	8.8
	55	-	-	-	-	-	-	25 700	13.7	32 000	13.7	39 200	13.8	47 500	13.8	56 900	13.8
SZ240	35	22 400	11.7	28 800	11.8	36 400	11.9	45 300	12.1	55 800	12.2	67 900	12.4	81 800	12.5	97 800	12.6
	55	-	-	21 800	17.9	28 000	18.0	35 300	18.2	43 800	18.4	53 800	18.7	65 300	18.9	78 500	19.2
SZ300	35	28 600	13.7	36 100	13.9	45 000	14.1	55 400	14.3	67 500	14.5	81 600	14.7	97 800	14.9	116 300	15.2
	55	-	-	28 400	21.2	35 700	21.6	44 400	22.1	54 500	22.5	66 400	22.9	80 100	23.2	95 900	23.6
SZ380	35	36 000	16.9	45 300	17.3	56 400	17.6	69 400	18.0	84 600	18.3	102 200	18.6	122 400	18.9	145 400	19.4
	55	-	-	35 000	26.1	44 200	26.6	55 000	27.0	67 500	27.4	82 100	27.8	98 900	28.1	118 200	28.5
SZ170	35	14 200	7.8	18 300	7.9	23 200	8.0	29 100	8.0	36 000	8.0	44 000	8.0	53 200	8.0	63 700	7.9
	55	-	-	-	-	-	-	22 300	12.3	27 900	12.4	34 500	12.4	42 100	12.4	50 900	12.4
SZ180	35	15 000	8.2	19 400	8.3	24 600	8.3	30 800	8.4	38 000	8.4	46 400	8.4	56 100	8.3	67 100	8.2
	55	-	-	-	-	-	-	23 600	13.0	29 500	13.0	36 400	13.1	44 400	13.0	53 600	13.0
SZ200	35	16 000	8.7	20 600	8.8	26 100	8.8	32 700	8.9	40 300	8.9	49 200	8.9	59 300	8.8	70 900	8.7
	55	-	-	-	-	-	-	25 000	13.8	31 300	13.9	38 600	13.9	47 000	13.8	56 600	13.8
SZ220	35	18 400	9.9	23 700	9.9	30 000	10.0	37 400	10.1	46 100	10.1	56 100	10.0	67 500	10.0	80 600	9.8
	55	-	-	-	-	-	-	28 600	15.8	35 800	15.8	44 000	15.8	53 500	15.7	64 400	15.5
SZ230	35	20 000	10.8	25 800	10.8	32 800	10.9	40 900	10.9	50 400	10.9	61 200	10.9	73 700	10.8	87 700	10.7
	55	-	-	-	-	-	-	31 100	17.4	38 900	17.3	48 000	17.3	58 400	17.2	70 200	17.0
SZ242	35	21 600	11.4	27 900	11.5	35 200	11.6	43 800	11.6	53 800	11.6	65 400	11.5	78 600	11.4	93 700	11.2
	55	-	-	-	-	-	-	33 600	18.3	41 800	18.4	51 300	18.3	62 300	18.1	74 800	17.9
SZ250	35	21 200	11.4	27 500	11.4	34 900	11.5	43 500	11.5	53 600	11.5	65 200	11.4	78 300	11.4	93 300	11.3
	55	-	-	-	-	-	-	33 100	18.3	41 400	18.3	51 100	18.2	62 100	18.1	74 700	17.9
SZ268	35	24 100	12.6	31 000	12.7	39 000	12.8	48 500	12.9	59 500	12.9	72 300	12.9	87 000	12.9	103 800	12.8
	55	-	-	-	-	-	-	37 600	20.3	46 700	20.3	57 300	20.3	69 400	20.2	83 400	20.1
SZ271	35	23 600	12.4	30 200	12.5	38 100	12.6	47 400	12.6	58 300	12.6	70 900	12.7	85 400	12.7	102 000	12.7
	55	-	-	-	-	-	-	36 900	19.9	45 800	19.9	56 200	19.9	68 200	19.9	82 000	19.8
SZ281	35	25 200	13.1	32 300	13.2	40 800	13.3	50 700	13.4	62 200	13.4	75 600	13.4	90 900	13.4	108 500	13.4
	55	-	-	-	-	-	-	39 300	21.2	48 800	21.2	59 900	21.2	72 600	21.1	87 200	21.0
SZ285	35	25 200	13.0	32 400	13.2	41 000	13.3	51 000	13.3	62 700	13.3	76 200	13.3	91 700	13.3	109 300	13.2
	55	-	-	-	-	-	-	39 400	21.0	49 000	21.0	60 200	21.0	73 200	21.0	88 000	20.9
SZ290	35	25 200	13.4	32 500	13.5	41 000	13.5	51 100	13.6	62 800	13.7	76 200	13.7	91 600	13.6	109 000	13.5
	55	-	-	-	-	-	-	39 100	21.4	48 800	21.5	59 900	21.5	72 700	21.4	87 300	21.3
SZ296	35	26 600	13.8	34 000	13.9	42 800	14.0	53 200	14.1	65 300	14.2	79 300	14.2	95 500	14.3	114 000	14.4
	55	-	-	-	-	-	-	41 700	22.2	51 700	22.3	63 200	22.3	76 600	22.3	92 000	22.3
SZ310	35	27 000	14.2	34 700	14.4	43 900	14.5	54 700	14.5	67 200	14.6	81 600	14.6	98 000	14.5	116 700	14.4
	55	-	-	-	-	-	-	41 900	22.9	52 200	22.9	64 100	22.9	77 800	22.9	93 400	22.8
SZ320	35	29 200	14.7	37 300	14.9	47 000	15.0	58 400	15.1	71 800	15.2	87 200	15.2	105 000	15.2	125 400	15.2
	55	-	-	-	-	-	-	45 700	23.6	56 700	23.7	69 400	23.8	84 200	23.8	101 300	23.9
SZ322	35	28 700	14.9	36 800	15.0	46 300	15.1	57 500	15.1	70 600	15.2	85 800	15.3	103 300	15.4	123 300	15.5
	55	-	-	-	-	-	-	45 100	23.9	55 900	24.0	68 400	24.0	82 900	24.0	99 600	24.0
SZ350	35	30 500	15.9	39 100	16.1	49 300	16.2	61 200	16.3	75 200	16.4	91 200	16.4	109 500	16.4	130 300	16.4
	55	-	-	-	-	-	-	47 200	25.4	58 600	25.6	71 900	25.6	87 100	25.7	104 400	25.7
SZ370	35	32 700	17.1	42 000	17.3	52 900	17.4	65 800	17.5	80 700	17.6	98 000	17.7	117 700	17.7	140 000	17.6
	55	-	-	-	-	-	-	50 700	27.4	63 000	27.5	77 200	27.6	93 500	27.6	112 100	27.6
SZ425	35	38 400	20														

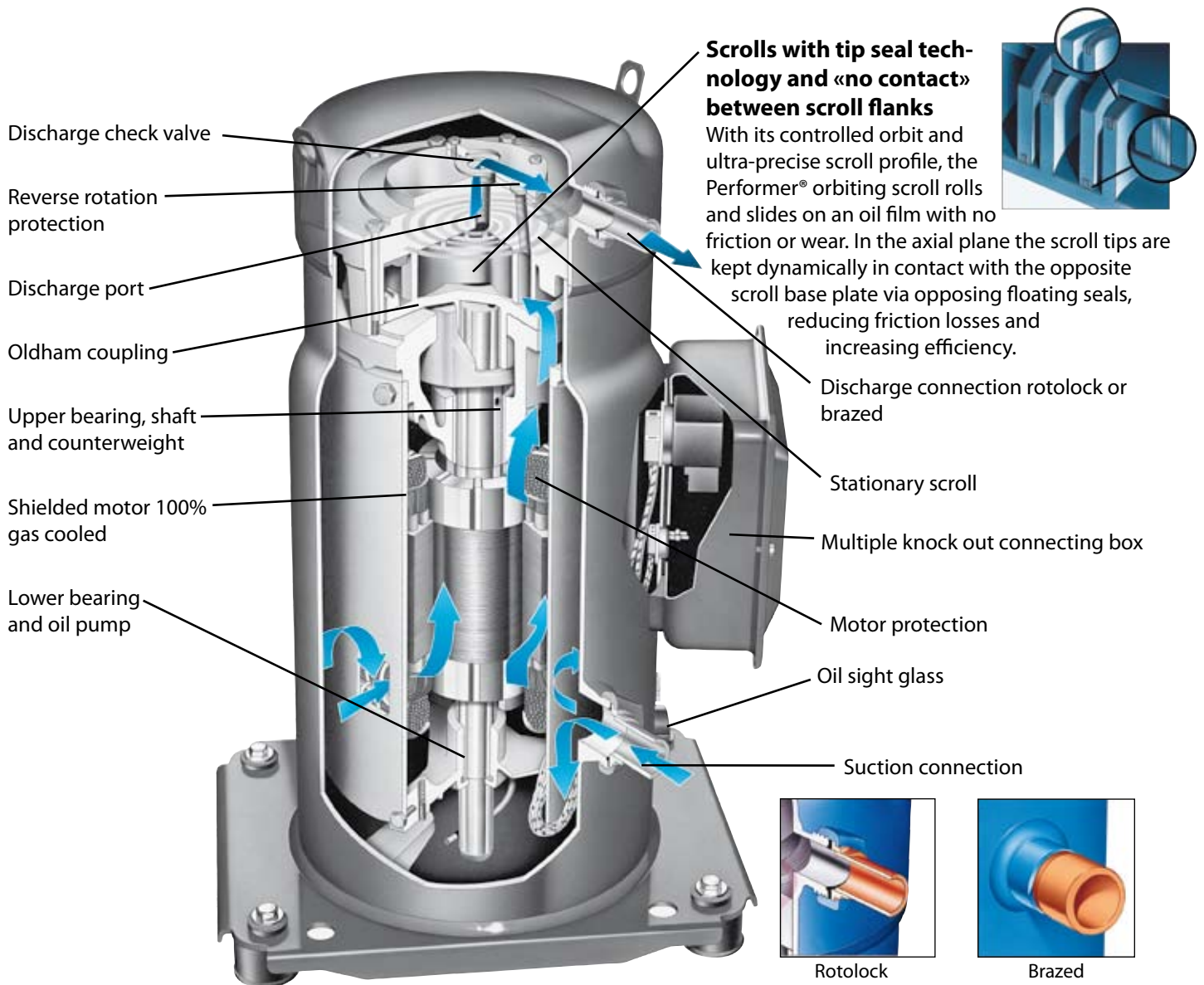

Product range tandem compressors

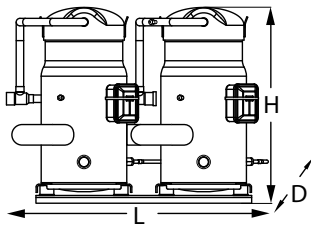

	L	D	H
S170 - 180 - 200	757	423	532
S 220 - 242	777	443	582
S 230 - 250	836	480	603
S 320	911	480	657
S 296 - 322	924	438	614
S 350 - 370	1004	495	717

All dimensions in mm

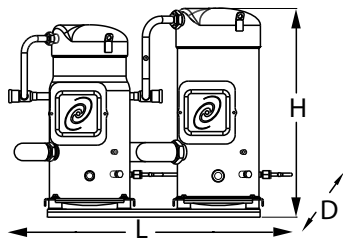

	L	D	H
S 268 - 271 - 281	930	441	614
S 285	884	480	657
S 290 - 310	924	480	705
S 425	1029	552	729
S 485	1029	552	740

All dimensions in mm

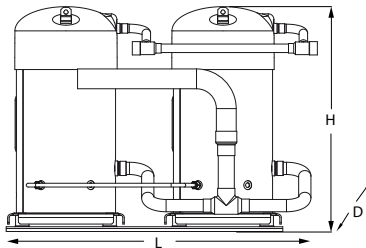

	L	D	H
S 482	984	510	730
S 540	984	510	740
S 600	984	510	740
S 620	1058	595	770
S 680	1058	595	770
S 760	1063	595	770

All dimensions in mm

Model	Composition	Nominal voltage				
		200-230/ 3/60	400/3/50 460/3/60	230/3/50	500/3/50 575/3/60	380/3/60
		Motor voltage code				
		3	4	6	7	9
SM/SZ170	S084 + S084					
SM/SZ180	S090 + S090					
SM/SZ200	S100 + S100					
SM/SZ220	S110 + S110					
SM/SZ230	S115 + S115					
SM/SZ242	S120 + S120					
SM/SZ250	S125 + S125					
SM/SZ268	S148 + S120					
SM/SZ271	S161 + S110					
SM/SZ281	S161 + s120					
SM/SZ285	S160 + S125					
SM/SZ290	S175 + S115					
SM/SZ296	S148 + S148					
SM/SZ310	S185 + S125					
SM/SZ320	S160 + S160					
SM/SZ322	S161 + S161					
SM/SZ350	S175 + S175					
SM/SZ370	S185 + S185					
SZ425	S240 + S185					
SY/SZ482	S240 + S240					
SZ485	S300 + S185					
SY/SZ540	S300 + S240					
SY/SZ600	S300 + S300					
SY/SZ620 *	S240 + S380					
SY/SZ680 *	S300 + S380					
SY/SZ760 *	S380 + S380					

* SY models only available for 400/3/50Hz Factory built Field assembly

Family, lubricant & refrigerant	Nominal capacity	Voltage	Evolution index
SZ	285	4	A

Family, lubricant & refrigerant
SM: Scroll, Mineral oil, for R22
SY: Scroll, POE lubricant, for R22
SZ: Scroll, POE lubricant, for R407C - R134a

Motor voltage code:
Refer to above table

Nominal capacity
in thousand Btu/h
at 60 Hz, R22,
ARI conditions

PRODUCT RANGE

Model	Voltage code - Nominal voltage - Range				
	3	4	6	7	9
	200-230/3/60	400/3/50 460/3/60	230/3/50	500/3/50 575/3/60	380/3/60
SH090	●	●	●	●	●
SH120	●	●	●	●	●
SH161	●	●	●	●	●
SH180	●●	●●	-	●●	●●
SH240	●●	●●	-	●●	●●
SH300	●●	●●	-	●●	●●
SH380	●●	●●	-	●●	●●

Model	Dimensions			
	D (mm)	H (mm)	H1 (mm)	H2 (mm)
SH090	243	483	235	452
SH120	243	540	278	509
SH161	243	540	278	509
SH180	318	679	331	664
SH240	318	679	331	664
SH300	333	723	331	658
SH380	333	755	331	696

● Brazed version ● Rotolock version

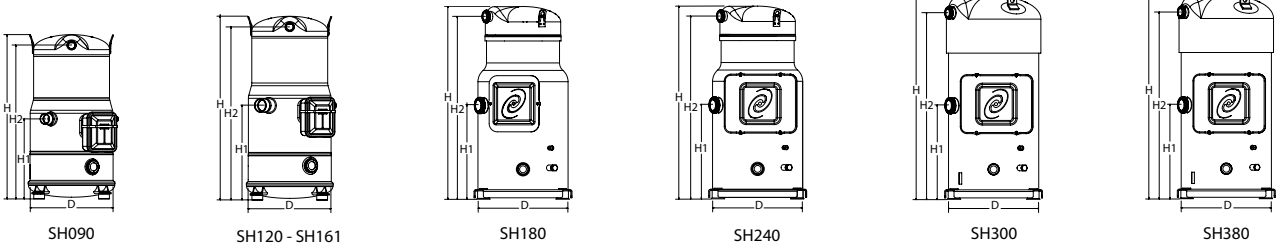

Tandem model	Composition	Voltage code - Nominal voltage - Range				
		3	4	6	7	9
		200-230/3/60	400/3/50 460/3/60	230/3/50	500/3/50 575/3/60	380/3/60
SH182	SH090 + SH090	●	●	●	●	●
SH210	SH120 + SH090	●	●	●	●	●
SH242	SH120 + SH120	●	●	●	●	●
SH281	SH161 + SH120	●	●	●	●	●
SH322	SH161 + SH161	●	●	●	●	●
SH360	SH180 + SH180	●	●	-	●	●
SH420	SH240 + SH180	●	●	-	●	●
SH480	SH300 + SH180	●	●	-	●	●
SH482	SH240 + SH240	●	●	-	●	●
SH540	SH300 + SH240	●	●	-	●	●
SH600	SH300 + SH300	●	●	-	●	●
SH760	SH380 + SH380	●	●	-	●	●

Tandem model	Dimensions		
	L (mm)	W (mm)	H (mm)
SH182	732	425	506
SH210	732	425	563
SH242	724	425	563
SH281	724	425	563
SH322	724	425	563
SH360	985	526	700
SH420	987	533	700
SH480	987	535	737
SH482	985	533	700
SH540	987	535	737
SH600	985	535	737
SH760	990	535	770

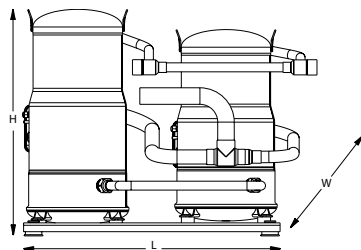

SH182 - SH210 - SH242 - SH281 - SH322

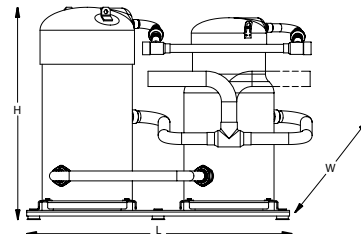

SH360 - SH420 - SH480 - SH482 - SH540 - SH600 - SH760

NAMEPLATE REFERENCE

SH | 300 | A | 4 | AB | A

SH: Scroll, for R410A

Nominal capacity in thousand Btu/h at 60 Hz, R410A, ARI conditions

UL index

Motor voltage code:
 3: 200-230/3/60
 4: 380-400/3/50 - 460/3/60
 6: 230/3/50
 7: 500/3/50 - 575/3/60
 9: 380/3/60

Evolution index

Motor protection

L: Internal overload protector

A: Electronic, 24V

B: Electronic, SH180: 230V

C: Customized electrical box

Suction and discharge connections

A: Brazed connections

M: Rotolock connections

SH - R410A

50 Hz PERFORMANCE DATA

Model	To	-20		-15		-10		-5		0		5		10		15	
	Tc	Qo	Pe	Qo	Pe	Qo	Pe	Qo	Pe	Qo	Pe	Qo	Pe	Qo	Pe	Qo	Pe
SH090-4	35	9 730	4.5	12 140	4.6	14 960	4.7	18 230	4.8	21 990	4.8	26 310	4.9	31 230	4.9	36 790	4.9
	45	8 460	5.6	10 670	5.7	13 220	5.7	16 180	5.8	19 590	5.9	23 510	5.9	27 970	6.0	33 040	6.0
	55	-	-	-	-	11 330	7.1	13 930	7.1	16 940	7.2	20 410	7.2	24 390	7.3	28 930	7.4
SH120-4	35	13 070	5.9	16 310	6.0	20 090	6.1	24 480	6.2	29 540	6.3	35 330	6.4	41 930	6.5	49 400	6.5
	45	11 370	7.4	14 340	7.4	17 780	7.5	21 750	7.6	26 330	7.7	31 590	7.8	37 580	7.9	44 380	7.9
	55	-	-	-	-	15 220	9.3	18 720	9.4	22 760	9.5	27 420	9.5	32 750	9.6	38 820	9.7
SH161-4	35	17 320	7.8	21 470	7.9	26 300	7.9	31 900	8.0	38 350	8.0	45 730	8.1	54 120	8.2	63 620	8.4
	45	15 080	9.8	18 890	9.8	23 310	9.8	28 420	9.8	34 310	9.9	41 050	9.9	48 730	10.0	57 450	10.1
	55	-	-	-	-	19 850	12.4	24 350	12.3	29 540	12.3	35 520	12.3	42 380	12.3	50 200	12.3
SH180-4	35	19 200	9.4	23 870	9.3	29 340	9.2	35 740	9.2	43 150	9.1	51 690	9.1	61 460	9.1	72 560	9.1
	45	16 080	11.8	20 530	11.6	25 670	11.4	31 610	11.3	38 450	11.3	46 310	11.2	55 280	11.2	65 470	11.2
	55	-	-	-	-	21 790	14.3	27 120	14.1	33 230	14.0	40 240	13.9	48 260	13.9	57 400	13.9
SH240-4	35	26 450	12.2	32 880	12.2	40 380	12.2	49 070	12.2	59 080	12.2	70 540	12.2	83 570	12.3	98 300	12.6
	45	22 840	15.2	28 750	15.3	35 610	15.3	43 550	15.3	52 680	15.2	63 140	15.2	75 070	15.2	88 570	15.3
	55	-	-	-	-	30 370	19.2	37 400	19.2	45 520	19.1	54 850	19.1	65 540	19.0	77 710	19.0
SH300-4	35	33 720	16.0	41 790	16.1	51 210	16.2	62 140	16.2	74 710	16.2	89 110	16.2	105 470	16.2	123 970	16.2
	45	29 260	19.5	36 720	19.7	45 390	19.7	55 410	19.8	66 960	19.8	80 190	19.8	95 250	19.8	112 320	19.7
	55	-	-	-	-	38 620	24.3	47 480	24.3	57 730	24.4	69 540	24.3	83 060	24.3	98 470	24.2
SH380-4	35	40 130	18.7	49 630	18.7	60 680	18.7	73 500	18.8	88 250	18.9	105 140	19.0	124 360	19.1	146 090	19.1
	45	35 000	23.0	43 710	22.9	53 800	22.9	65 460	23.0	78 890	23.1	94 280	23.2	111 820	23.3	131 710	23.4
	55	-	-	-	-	45 930	28.3	56 170	28.3	68 020	28.4	81 660	28.5	97 290	28.6	115 110	28.7
SH182-4	35	19 180	9.0	23 930	9.2	29 470	9.4	35 900	9.5	43 330	9.6	51 830	9.8	61 520	9.8	72 480	9.9
	45	16 670	11.2	21 010	11.3	26 050	11.4	31 870	11.6	38 600	11.7	46 310	11.9	55 110	12.0	65 100	12.1
	55	-	-	-	-	22 320	14.2	27 450	14.3	33 380	14.4	40 210	14.5	48 050	14.6	56 990	14.7
SH210-4	35	22 460	10.5	28 030	10.6	34 520	10.8	42 060	11.0	50 760	11.2	60 720	11.3	72 060	11.4	84 900	11.5
	45	19 540	13.0	24 630	13.1	30 530	13.3	37 360	13.4	45 240	13.6	54 270	13.7	64 570	13.9	76 260	14.0
	55	-	-	-	-	26 150	16.4	32 160	16.5	39 110	16.7	47 110	16.8	56 280	16.9	66 740	17.0
SH242-4	35	25 750	11.9	32 130	12.1	39 580	12.3	48 220	12.5	58 180	12.7	69 600	12.8	82 600	12.9	97 320	13.0
	45	22 400	14.7	28 240	14.9	35 020	15.1	42 850	15.2	51 880	15.4	62 230	15.6	74 030	15.7	87 430	15.9
	55	-	-	-	-	29 980	18.7	36 880	18.8	44 840	18.9	54 010	19.1	64 510	19.2	76 480	19.3
SH281-4	35	29 930	13.8	37 210	13.9	45 690	14.1	55 530	14.2	66 860	14.3	79 840	14.5	94 610	14.7	111 320	14.9
	45	26 050	17.2	32 730	17.3	40 470	17.4	49 420	17.5	59 730	17.6	71 550	17.7	85 020	17.8	100 300	18.0
	55	-	-	-	-	34 540	21.7	42 420	21.8	51 520	21.8	62 000	21.9	74 000	21.9	87 690	22.0
SH322-4	35	34 110	15.7	42 290	15.7	51 810	15.8	62 840	15.9	75 540	16.0	90 080	16.2	106 620	16.4	125 330	16.7
	45	29 700	19.6	37 220	19.6	45 930	19.7	55 990	19.7	67 580	19.7	80 870	19.8	96 010	19.9	113 170	20.1
	55	-	-	-	-	39 110	24.7	47 960	24.7	58 200	24.6	69 980	24.6	83 500	24.6	98 900	24.7
SH360-4	35	37 820	18.8	47 020	18.6	57 810	18.4	70 400	18.3	85 010	18.3	101 830	18.2	121 080	18.2	142 950	18.1
	45	31 670	23.6	40 450	23.2	50 580	22.9	62 280	22.7	75 760	22.5	91 230	22.4	108 900	22.4	128 980	22.4
	55	-	-	-	-	42 930	28.6	53 420	28.3	65 460	28.0	79 270	27.8	95 080	27.8	113 080	27.7
SH420-4	35	44 960	21.6	55 890	21.5	68 680	21.4	83 540	21.4	100 700	21.3	120 400	21.3	142 860	21.4	168 300	21.6
	45	38 330	27.0	48 540	26.9	60 360	26.7	74 030	26.6	89 770	26.5	107 810	26.4	128 390	26.4	151 730	26.5
	55	-	-	-	-	51 380	33.5	63 550	33.3	77 560	33.1	93 670	33.0	112 100	32.9	133 080	32.8
SH480-4	35	52 120	25.5	64 680	25.4	79 350	25.4	96 410	25.4	116 100	25.4	138 690	25.3	164 430	25.3	193 580	25.3
	45	44 660	31.4	56 390	31.3	69 990	31.2	85 720	31.1	103 830	31.1	124 600	31.0	148 270	31.0	175 120	30.9
	55	-	-	-	-	59 500	38.6	73 480	38.5	89 600	38.4	108 130	38.3	129 360	38.2	153 530	38.1
SH482-4	35	52 110	24.4	64 770	24.4	79 540	24.4	96 670	24.3	116 390	24.3	138 970	24.4	164 630	24.7	193 640	25.1
	45	44 990	30.3	56 640	30.5	70 150	30.5	85 780	30.5	103 780	30.4	124 400	30.3	147 880	30.4	174 490	30.5
	55	-	-	-	-	59 830	38.3	73 680	38.3	89 670	38.2	108 060	38.1	129 120	38.0	153 090	37.9
SH540-4	35	59 270	28.2	73 550	28.3	90 220	28.4	109 540	28.4	131 790	28.4	157 250	28.4	186 210	28.5	218 930	28.8
	45	51 310	34.7	64 490	34.9	79 780	35.0	97 470	35.0	117 850	35.0	141 180	35.0	167 770	35.0	197 880	35.0
	55	-	-	-	-	67 960	43.4	83 610	43.5	101 700	43.5	122 530	43.4	146 370	43.3	173 540	43.2
SH600-4	35	66 430	32.0	82 340	32.2	100 890	32.3	122 410	32.4	147 190	32.4	175 540	32.4	207 780	32.4	244 210	32.4
	45	57 640	39.0	72 340	39.3	89 410	39.5	109 160	39.6	131 910	39.6	157 970	39.5	187 650	39.5	221 270	39.4
	55	-	-	-	-	76 080	48.5	93 530	48.6	113 730	48.7	136 990	48.6	163 630	48.6	193 990	48.4
SH760-4	35	80 260	37.4	99 250	37.4	121 370	37.5	147 000	37.7	176 510	37.8	210 290	38.0	248 720	38.1	292 170	38.1
	45	70 000	46.0	87 420	45.9	107 600	45.9	130 930	46.0	157 790	46.2	188 570	46.5	223 650	46.7	263 420	46.8
	55	-	-	-	-	91 850	56.7	112 350	56.7	136 040	56.8	163 310	57.0	194 580	57.2	230 230	57.4

Performance data for SH090-120-161-380 and corresponding tandem models are provisional data

Legend: **To:** Evaporating temperature in °C **Qo:** Cooling capacity in W Superheat = 11.1 K Voltage: 400 V / 3 / 50 Hz
Tc: Condensing temperature in °C **Pe:** Power input in kW Subcooling = 8.3 K

Model	To	-20		-15		-10		-5		0		5		10		15	
	Tc	Qo	Pe	Qo	Pe	Qo	Pe	Qo	Pe	Qo	Pe	Qo	Pe	Qo	Pe	Qo	Pe
SH090-4	35	11 800	5.4	14 690	5.5	18 050	5.6	21 940	5.7	26 440	5.8	31 590	5.9	37 450	6.0	44 100	6.1
	45	10 340	6.7	12 990	6.7	16 060	6.8	19 620	6.9	23 720	7.0	28 430	7.1	33 800	7.2	39 890	7.3
	55	-	-	-	-	13 830	8.4	16 980	8.5	20 620	8.5	24 820	8.6	29 630	8.7	35 120	8.8
SH120-4	35	16 010	7.2	19 930	7.3	24 490	7.4	29 760	7.5	35 840	7.7	42 790	7.8	50 710	8.1	59 660	8.3
	45	13 990	8.8	17 630	8.9	21 820	9.0	26 640	9.1	32 180	9.2	38 520	9.4	45 740	9.5	53 910	9.8
	55	-	-	-	-	18 730	11.1	23 050	11.1	28 010	11.2	33 680	11.3	40 150	11.5	47 490	11.6
SH161-4	35	21 390	9.2	26 330	9.3	32 080	9.5	38 740	9.6	46 420	9.7	55 210	9.9	65 220	10.1	76 560	10.3
	45	18 740	11.4	23 260	11.5	28 510	11.6	34 590	11.7	41 590	11.8	49 630	11.9	58 800	12.1	69 220	12.2
	55	-	-	-	-	24 480	14.3	29 850	14.4	36 070	14.5	43 240	14.6	51 460	14.7	60 830	14.8
SH180-4	35	24 030	10.8	29 730	10.8	36 350	10.9	44 030	10.9	52 900	10.9	63 090	10.9	74 730	10.9	87 960	10.9
	45	20 280	13.5	25 600	13.5	31 740	13.5	38 820	13.5	46 970	13.5	56 340	13.6	67 050	13.6	79 230	13.6
	55	-	-	-	-	26 960	16.8	33 350	16.7	40 710	16.7	49 160	16.7	58 850	16.7	69 900	16.7
SH240-4	35	32 870	14.5	40 560	14.6	49 510	14.6	59 880	14.7	71 820	14.7	85 500	14.8	101 070	15.0	118 700	15.3
	45	28 840	17.9	35 880	18.0	44 040	18.1	53 470	18.2	64 330	18.3	76 790	18.3	91 000	18.4	107 130	18.5
	55	-	-	-	-	38 010	22.5	46 350	22.6	55 980	22.7	67 060	22.7	79 760	22.8	94 230	22.9
SH300-4	35	40 840	19.1	50 620	19.3	62 000	19.4	75 200	19.5	90 390	19.6	107 800	19.7	127 620	19.8	150 060	20.0
	45	35 730	23.2	44 700	23.4	55 100	23.6	67 130	23.7	81 000	23.8	96 900	23.8	115 030	23.9	135 610	24.0
	55	-	-	-	-	47 350	28.8	57 970	28.9	70 260	29.0	84 410	29.1	100 620	29.1	119 100	29.1
SH380-4	35	48 760	22.6	60 230	22.7	73 640	22.9	89 230	23.0	107 250	23.2	127 950	23.4	151 580	23.8	178 390	24.3
	45	42 710	27.5	53 170	27.7	65 360	27.8	79 540	27.9	95 960	28.0	114 860	28.2	136 480	28.4	161 090	28.8
	55	-	-	-	-	56 080	34.0	68 560	34.1	83 070	34.2	99 870	34.3	119 210	34.5	141 320	34.7
SH182-4	35	23 250	10.8	28 930	11.0	35 550	11.2	43 230	11.4	52 080	11.6	62 220	11.8	73 780	12.1	86 870	12.3
	45	20 370	13.3	25 590	13.5	31 640	13.7	38 650	13.8	46 730	14.0	56 000	14.2	66 580	14.4	78 590	14.6
	55	-	-	-	-	27 240	16.8	33 450	16.9	40 630	17.1	48 890	17.3	58 370	17.4	69 180	17.6
SH210-4	35	27 390	12.6	34 090	12.8	41 900	13.0	50 930	13.2	61 340	13.5	73 260	13.8	86 840	14.1	102 200	14.5
	45	23 970	15.5	30 160	15.6	37 310	15.8	45 560	16.0	55 060	16.2	65 940	16.5	78 340	16.8	92 400	17.1
	55	-	-	-	-	32 070	19.5	39 430	19.6	47 900	19.8	57 620	20.0	68 730	20.2	81 370	20.4
SH242-4	35	31 530	14.3	39 260	14.5	48 240	14.7	58 630	15.0	70 600	15.3	84 300	15.7	99 890	16.1	117 530	16.6
	45	27 570	17.6	34 720	17.8	42 980	17.9	52 480	18.2	63 400	18.4	75 890	18.7	90 110	19.1	106 210	19.5
	55	-	-	-	-	36 890	22.1	45 410	22.3	55 170	22.4	66 350	22.6	79 090	22.9	93 560	23.2
SH281-4	35	36 840	16.4	45 570	16.6	55 720	16.8	67 480	17.1	81 020	17.4	96 530	17.8	114 190	18.1	134 180	18.6
	45	32 240	20.2	40 280	20.3	49 570	20.5	60 310	20.8	72 670	21.0	86 830	21.3	102 970	21.6	121 290	22.0
	55	-	-	-	-	42 560	25.4	52 110	25.5	63 120	25.7	75 760	25.9	90 230	26.1	106 700	26.4
SH322-4	35	42 140	18.4	51 870	18.7	63 200	18.9	76 320	19.2	91 440	19.5	108 760	19.8	128 490	20.2	150 820	20.6
	45	36 910	22.7	45 830	22.9	56 170	23.1	68 140	23.3	81 930	23.6	97 770	23.8	115 840	24.1	136 360	24.5
	55	-	-	-	-	48 230	28.7	58 810	28.8	71 060	28.9	85 180	29.1	101 370	29.3	119 830	29.6
SH360-4	35	47 330	21.5	58 570	21.7	71 620	21.8	86 750	21.8	104 210	21.9	124 280	21.9	147 210	21.8	173 270	21.8
	45	39 950	27.1	50 440	27.1	62 530	27.1	76 470	27.1	92 540	27.1	110 990	27.1	132 080	27.2	156 080	27.3
	55	-	-	-	-	53 120	33.6	65 710	33.5	80 200	33.3	96 850	33.3	115 930	33.3	137 690	33.5
SH420-4	35	56 040	25.2	69 240	25.4	84 580	25.5	102 360	25.6	122 850	25.7	146 360	25.8	173 160	25.9	203 550	26.2
	45	48 380	31.4	60 560	31.6	74 640	31.7	90 900	31.7	109 640	31.8	131 130	31.9	155 680	32.0	183 560	32.2
	55	-	-	-	-	64 000	39.3	78 510	39.4	95 240	39.4	114 480	39.4	136 530	39.5	161 660	39.6
SH480-4	35	63 890	29.9	79 140	30.1	96 880	30.3	117 440	30.4	141 140	30.5	168 330	30.6	199 320	30.8	234 440	31.0
	45	55 170	36.7	69 250	36.9	85 540	37.1	104 360	37.2	126 050	37.3	150 940	37.4	179 350	37.5	211 620	37.6
	55	-	-	-	-	73 200	45.6	89 960	45.7	109 310	45.7	131 570	45.7	157 080	45.7	186 160	45.8
SH482-4	35	64 750	28.9	79 910	29.1	97 540	29.2	117 960	29.3	141 490	29.5	168 430	29.7	199 110	30.0	233 830	30.5
	45	56 820	35.7	70 690	36.0	86 750	36.3	105 330	36.4	126 730	36.5	151 280	36.6	179 270	36.8	211 040	37.0
	55	-	-	-	-	74 880	45.0	91 310	45.2	110 280	45.4	132 110	45.5	157 130	45.6	185 630	45.7
SH540-4	35	72 600	33.6	89 810	33.8	109 850	34.0	133 050	34.2	159 780	34.3	190 400	34.5	225 260	34.8	264 720	35.3
	45	63 610	41.0	79 380	41.4	97 650	41.7	118 790	41.9	143 150	42.0	171 080	42.1	202 950	42.3	239 100	42.5
	55	-	-	-	-	84 080	51.3	102 760	51.6	124 350	51.7	149 200	51.8	177 680	51.9	210 130	52.0
SH600-4	35	80 450	38.2	99 720	38.5	122 150	38.8	148 130	39.0	178 080	39.1	212 370	39.3	251 420	39.6	295 610	40.0
	45	70 400	46.3	88 070	46.8	108 550	47.1	132 250	47.3	159 570	47.5	190 890	47.6	226 620	47.8	267 160	48.0
	55	-	-	-	-	93 270	57.6	114 210	57.9	138 420	58.0	166 290	58.1	198 230	58.1	234 630	58.1
SH760-4	35	97 520	45.2	120 460	45.5	147 270	45.7	178 450	46.0	214 500	46.3	255 900	46.9	303 160	47.6	356 780	48.6
	45	85 420	54.9	106 340	55.3	130 730	55.6	159 090	55.8	191 920	56.1	229 710	56.4	272 970	56.8	322 180	57.5
	55	-	-	-	-	112 160	67.9	137 120	68.2	166 150	68.4	199 750	68.7	238 410	69.0	282 650	69.4

Performance data for SH090-120-161-380 and corresponding tandem models are provisional data

Legend: To: Evaporating temperature in °C
Tc: Condensing temperature in °C

Qo: Cooling capacity in W
Pe: Power input in kW

Superheat = 11.1 K
Subcooling = 8.3 K

Voltage: 460 V / 3 / 60 Hz

CODE NUMBERS

Compressor model	Connections	Motor protection	code numbers for industrial packs				
			3	4	6	7	9
			200-230/3/60	400/3/50 460/3/60	230/3/50	500/3/50 575/3/60	380/3/60
SH090	Brazed	Internal	120H0002	120H0004	120H0006	120H0008	120H0010
SH120	Brazed	Internal	120H0012	120H0014	120H0016	120H0018	120H0020
SH161	Brazed	Internal	120H0022	120H0024	120H0026	120H0028	120H0030
SH180	Brazed	M24	120H0032	120H0040	-	120H0048	120H0056
	Brazed	M230	120H0034	120H0042	-	120H0050	120H0058
	Rotolock	M24	120H0036	120H0044	-	120H0052	120H0060
	Rotolock	M230	120H0038	120H0046	-	120H0054	120H0062
SH240	Brazed	M24	120H0064	120H0075	-	120H0086	120H0097
	Brazed	M115-230	120H0066	120H0077	-	120H0088	120H0099
	Rotolock	M24	120H0071	120H0082	-	120H0093	120H0104
	Rotolock	M115-230	120H0073	120H0084	-	120H0095	120H0106
SH300	Brazed	M24	120H0108	120H0119	-	120H0130	120H0141
	Brazed	M115-230	120H0110	120H0121	-	120H0132	120H0143
	Rotolock	M24	120H0115	120H0126	-	120H0137	120H0148
	Rotolock	M115-230	120H0117	120H0128	-	120H0139	120H0150
SH380	Brazed	M24	120H0152	120H0160	-	120H0168	120H0176
	Brazed	M115-230	120H0154	120H0162	-	120H0170	120H0178
	Rotolock	M24	120H0156	120H0164	-	120H0172	120H0180
	Rotolock	M115-230	120H0158	120H0166	-	120H0174	120H0182

			code numbers for single packs				
SH090	Brazed	Internal	120H0001	120H0003	120H0005	120H0007	120H0009
SH120	Brazed	Internal	120H0011	120H0013	120H0015	120H0017	120H0019
SH161	Brazed	Internal	120H0021	120H0023	120H0025	120H0027	120H0029
SH180	Brazed	M24	120H0031	120H0039	-	120H0047	120H0055
	Brazed	M230	120H0033	120H0041	-	120H0049	120H0057
	Rotolock	M24	120H0035	120H0043	-	120H0051	120H0059
	Rotolock	M230	120H0037	120H0045	-	120H0053	120H0061
SH240	Brazed	M24	120H0063	120H0074	-	120H0085	120H0096
	Brazed	M115-230	120H0065	120H0076	-	120H0087	120H0098
	Rotolock	M24	120H0070	120H0081	-	120H0092	120H0103
	Rotolock	M115-230	120H0072	120H0083	-	120H0094	120H0105
SH300	Brazed	M24	120H0107	120H0118	-	120H0129	120H0140
	Brazed	M115-230	120H0109	120H0120	-	120H0131	120H0142
	Rotolock	M24	120H0114	120H0125	-	120H0136	120H0147
	Rotolock	M115-230	120H0116	120H0127	-	120H0138	120H0149
SH380	Brazed	M24	120H0151	120H0159	-	120H0167	120H0175
	Brazed	M115-230	120H0153	120H0161	-	120H0169	120H0177
	Rotolock	M24	120H0155	120H0163	-	120H0171	120H0179
	Rotolock	M115-230	120H0157	120H0165	-	120H0173	120H0181



OPTYMA™ condensing units

Danfoss OPTYMA™ condensing units perfectly suit applications like:

- Cold stores and freezer rooms
- Beer and wine cellars
- Small food retail and mini markets
- Garage forecourt shops
- Display cabinets
- Ice cream freezers
- Bottle coolers
- Air driers
- Residential air conditioning

The optimum range of low-noise condensing units for quick installation

Based on many years of experience, we have developed a complete range of hermetic condensing units that meet even the highest standards.

OPTYMA condensing units are unique integral condensing units built around Danfoss components.

With specially-designed single fan units and a compressor platform for low temperatures, OPTYMA condensing units include features like high COP, low noise levels and energy consumption and a wide application range, as well as simple installation and maintenance.

The OPTYMA range is available for refrigerants R134a, R404A, R507 and R407C. Capacity ranges from 0 to 20.000 Watt (R134a). All units are fully wired and factory tested, reducing commissioning time on site.

Installation is effortless: just mount the unit, switch on the current, and the cooling process is up and running.

Product advantages	Customer benefits
<ul style="list-style-type: none"> · Energy-efficient · Low energy consumption · Electrical box: IP 54 · Low noise levels · Small dimensions · Built-in grab for easier handling on site · Base plate design allow easy mounting on wall brackets · Easy access to all components for improved serviceability and simplified maintenance 	<ul style="list-style-type: none"> · Integrated Danfoss design · Outstanding performance, even in the toughest applications · A minimal footprint, enabling installation in small spaces without compromising unit performance or service accessibility · Common Danfoss components, all stocked locally by wholesalers · Low noise operation · Reliable, high ambient operation and proven reliability in the most demanding applications · Energy saving benefits with fan speed control and selection of energy-efficient components

OPTYMA™ condensing unit R404A/R507 LBP

Test conditions	Unit	Platform	Version				Electrical code	HP	Condenser coil			Condenser fan Fan blade	Cooling capacity in [W] at evaporating temperature °C					
			A00	A01	A02	A04			Type	Airflow [m³/h]	Int. volume [dm³]		-45	-40	-35	-30	-25	
	CECOMAF	OP-LCHC004	TL	114X1208	114X1209		114X1211	G	¼	BG2	231	0.25	1 × 200	64	85	110	141	177
		OP-LCHC006	FR	114X1216	114X1217		114X1219	G	½	BG2	231	0.25	1 × 200	91	128	171	219	273
		OP-LCHC008	FR	114X1324	114X1325		114X1327	G	⅓	BG3	518	0.31	1 × 230	130	161	208	268	340
		OP-LCHC007	NL	114X1328	114X1329		114X1331	G	½	BG3	518	0.31	1 × 230	126	175	234	302	380
		OP-LCHC010	SC	114X1332	114X1333		114X1335	G	½	BG3	518	0.31	1 × 230			216	300	393
		OP-LCHC012	SC	114X1440	114X1441		114X1443	G	½	BG4	631	0.40	1 × 254	129	220	320	429	547
		OP-LCHC015	SC	114X1548	114X1549		114X1551	G	⅝	BG5	583	0.53	1 × 254	198	292	400	521	654
		OP-LCHC018	SC	114X1556	114X1557		114X1559	G	¾	BG5	583	0.53	1 × 254	232	349	475	610	751
		OP-LCHC021	SC	114X1564	114X1565		114X1567	G	⅞	BG5	583	0.53	1 × 254	291	405	535	680	840
		OP-LCHC026	GS	114X1672	114X1673		114X1675	G	1	BG6	1150	0.63	1 × 300	350	500	670	860	1.070
	RGT20	OP-LCHC034	GS	114X1780	114X1781		114X1783	G	1½	BG7	990	0.84	1 × 300	450	650	850	1.100	1.350
		OP-LCHC048	NT			114X5044	G	2½	A4	1.200	1.2	1 × 300	513	831	1.186	1.388	1.775	
						114X5030	D											
						114X5037	E											
		OP-LCHC068	NT			114X5045	G	3½	C4	2.150	2.3	1 × 350	730	1.121	1.629	2.193	2.834	
						114X5031	D											
						114X5038	E											
		OP-LCHC096	NT			114X5032	D	5	D4	2.000	3.1	1 × 350		1.474	2.083	2.771	3.567	
						114X5039	E											
						114X5033	D											
OP-LCHC108	NT			114X5040	E	5½	E4	3.150	2.5	1 × 400		1.630	2.390	3.332	4.297			
				114X5034	D													
				114X5041	E													
OP-LCHC136	NT			114X5035	D	7	G4	3.150	4.1	1 × 400		2.375	3.222	4.307	5.437			
				114X5042	E													
				114X5043	D													
OP-LCHC215	NT			114X5043	D	10	J4	6.000	4.4	1 × 500	2.407	3.565	4.910	6.588	8.308			
				114X5042	E													
				114X5036	D													
OP-LCHC271	NT			114X5043	E	13	L4	5.850	6.3	1 × 500	3.488	4.988	6.726	8.901	11.092			
				114X5096	G													
				114X5089	E													
	LGHC	OP-LGHC048	NT			114X5096	G	2½	C3	1.450	1.6	2 × 254	509	828	1.185	1.389	1.780	
				114X5089	E													
				114X5097	G													
		OP-LGHC068	NT			114X5083	D	3½	D3	2.800	1.5	2 × 300	711	1.096	1.595	2.147	2.773	
						114X5090	E											
						114X5084	D											
		OP-LGHC096	NT			114X5091	E	5	E3	2.100	2.2	2 × 300		1.485	2.103	2.806	3.622	
						114X5085	D											
						114X5092	E											
		OP-LGHC108	NT			114X5086	D	5½	G3	4.600	2.3	2 × 355		1.605	2.345	3.253	4.172	
				114X5092	E													
				114X5087	D													
OP-LGHC136	NT			114X5093	E	7	H3	3.600	4.7	2 × 355		2.449	3.415	4.472	5.678			
				114X5087	D													
				114X5094	E													
OP-LGHC215	NT			114X5088	D	10	L3	9.000	5.1	2 × 450	2.396	3.551	4.891	6.563	8.274			
				114X5088	D													
				114X5095	E													
OP-LGHC271	NT			114X5095	E	13	L3	8600	5.1	2 × 450	3.553	5.098	6.897	9.169	11.492			
				114X5095	E													
				114X5095	E													

Test condition EN 13215
Ambient temperature
Suction gas temperature

RGT 20
Constant suction gas temperature 32°C
20°C = 10K superheat

CECOMAF
Household & similar 32°C
32°C

Version
A00 Without valves and receiver for capillary tubes
A01 With receiver, 2 stop valves, bracket and copper pipes for KP
A02 With receiver, stop valves, universal pressure switch (KP17WB), flexible hoses and electrical box
A04 A01 + KP 17WB + FSA-Kit + power cord (except LCHC034)

Electrical characteristics

Unit	LRA compressor [A]		MCC compressor [A]						MCC Fan [A]	
	400 V/ 3 phase	230 V/ 1 phase	400 V/ 3 phase	Contactora	Overload relay	230 V/ 1 phase	Contactora	Overload relay	400 V/ 3 phase	230 V/ 1 phase
OP-LCHC004	-	5.7	-	-	-	-	-	-	-	0.19
OP-LCHC006	-	9	-	-	-	-	-	-	-	0.19
OP-LCHC008	-	10	-	-	-	-	-	-	-	0.25
OP-LCHC007	-	10.4	-	-	-	-	-	-	-	0.25
OP-LCHC010	-	14.8	-	-	-	-	-	-	-	0.25
OP-LCHC012	-	18.6	-	-	-	-	-	-	-	0.39
OP-LCHC015	-	21.8	-	-	-	-	-	-	-	0.39
OP-LCHC018	-	23.5	-	-	-	-	-	-	-	0.39
OP-LCHC021	-	23.4	-	-	-	-	-	-	-	0.39
OP-LCHC026	-	25.7	-	-	-	-	-	-	-	0.75
OP-LCHC034	-	26.6	-	-	-	-	-	-	-	0.75
OP-LCHC048	16	37	4.8	CI 6	TI 16C	11	CI 12	TI 16C	0.35	0.85
OP-LCHC068	25	53	8.4	CI 9	TI 16C	17	CI 15	TI 16C	0.5	1.2
OP-LCHC096	32	-	10.1	CI 12	TI 16C	-	-	-	0.5	1.2
OP-LCHC108	45	-	12.1	CI 12	TI 16C	-	-	-	0.7	1.3
OP-LCHC136	51	-	14.3	CI 15	TI 16C	-	-	-	0.7	1.3
OP-LCHC215	74	-	22.3	CI 25	TI 25C	-	-	-	1.2	3.4
OP-LCHC271	96	-	27	CI 30	TI 30C	-	-	-	1.2	3.4
OP-LGHC048	16	-	4.8	CI 6	TI 16C	11	CI 12	TI 16C	-	2x0.32
OP-LGHC068	25	-	8.4	CI 9	TI 16C	17	CI 20	TI 25C	2x0.35	2x0.85
OP-LGHC096	32	-	10.1	CI 12	TI 16C	-	-	-	2x0.35	2x0.85
OP-LGHC108	45	-	12.1	CI 12	TI 16C	-	-	-	2x0.5	2x1.2
OP-LGHC136	51	-	14.3	CI 15	TI 16C	-	-	-	2x0.5	2x1.2
OP-LGHC215	74	-	22.3	CI 25	TI 25C	-	-	-	2x1.2	2x1.7
OP-LGHC271	96	-	27	CI 30	TI 30C	-	-	-	2x1.2	2x1.7

				Application range [°C]	Power consumption [W] at evap. temp.		Receiver volume [l]	Dimensions [mm]								Weight [kg]				Compressor	
								Fig.	Height H [mm]	Width W [mm]	Length D [mm]	Dist. a [mm]	Dist. b [mm]	Suction line	Liquid line	A00	A01	A02	A04		
-20	-15	-10	-5		-25°C	-35°C															
218	265	318	378	38°C: -45°C till -5°C	162		0.8	1	226	304	432	310		10 mm	6 mm	12.0	13.8	17.8		TL4CLX	
332	397	468	542	38°C: -45°C till -10°C	267		0.8	2	226	304	432	310		10 mm	6 mm	15.1	16.7	17.8		FR6CLX	
420	508	599	692	38°C: -45°C till -10°C	336		1.1	2	256	321	444	325		10 mm	6 mm	15.5	17.9	18.9		FR8.5CLX	
497	563	667	779	38°C: -45°C till -10°C	336		1.1	3	256	321	444	325		10 mm	6 mm	15.5	17.9	18.9		NL7CLX	
496	609	730	860	38°C: -45°C till -10°C	373		1.1	4	256	321	444	325		10 mm	6 mm	15.5	17.9	18.9		SC10CLX	
672	804	943	1.088	38°C: -45°C till -15°C	479		1.1	4	296	331	451	325		10 mm	6 mm	19.8	22.0	22.9		SC12CLX	
799	955	1.122	1.298	38°C: -45°C till -10°C	558		1.1	4	296	331	473	325		10 mm	6 mm	21.1	23.4	24.2		SC15CLX	
899	1.052	1.212	1.379	38°C: -45°C till -15°C	649		1.1	4	296	331	513	365		10 mm	6 mm	21.1	23.4	24.2		SC18CLX	
1.014	1.202	1.407		38°C: -45°C till -15°C	754		1.1	4	296	331	513	365		10 mm	6 mm	21.1	23.4	24.2		SC21CLX	
1.290	1.525	1.770		38°C: -45°C till -23.3°C	1.023		2.4	7	340	430	480	310	385	12 mm	10 mm	36	39	40.5		GS26CLX	
1.625	1.900	2.200		38°C: -45°C till -23.3°C	1.170		2.4	7	340	430	480	310	385	12 mm	10 mm	39	42	43.5		GS34CLX	
2.186	2.614	3.054		46°C: -20°C till -35°C 43°C: -15°C till -40°C	935		3	5	402	500	600	400	465	5/8"	3/8"			54		NTZ048	
3.544	4.317	5.139			1.478	6	5	555	630	650	400	595	5/8"	1/2"				64		NTZ068	
4.461	5.442	6.499			1.851	6	5	555	630	650	400	595	7/8"	1/2"				78		NTZ096	
5.328	6.399	7.500			2.274	6	5	605	630	650	400	595	7/8"	1/2"				92		NTZ108	
6.685	8.030	9.466			3.029	8	5	656	755	700	400	720	7/8"	1/2"				95		NTZ136	
10.169	12.158	14.229			4.814	14	5	708	900	900	600	865	1 1/8"	5/8"				151		NTZ215	
13.431	15.900	18.435			6.312	14	5	759	900	900	600	865	1 1/8"	5/8"				166		NTZ271	
2.196	2.629	3.079			998	3	6	392	700	500	300	660	5/8"	3/8"				55		NTZ048	
3.463	4.210	5.009			1.487	6	6	442	800	600	400	760	5/8"	1/2"				62		NTZ068	
4.548	5.570	6.677			1.869	6	6	442	800	600	400	760	7/8"	1/2"				78		NTZ096	
5.139	6.135	7.132			2.267	8	6	555	1000	700	460	960	7/8"	1/2"				102		NTZ108	
7.020	8.496	10.080			3.130	8	6	555	1000	700	460	960	7/8"	1/2"				107		NTZ136	
10.124	12.092	14.156			4.413	14	6	671	1200	800	500	1160	1 1/8"	5/8"				152		NTZ215	
14.018	16.696	19.517			6.512	14	6	671	1200	800	500	1160	1 1/8"	5/8"				158		NTZ271	

Electrical Code

A Compressor 220 V/1 phase/50+60 Hz, fan 220 V/1 phase/50+60 Hz
D Compressor 400 V/3 phase/50 Hz, fan 400 V/3 phase/50 Hz

E Compressor 400 V/3 phase/50 Hz, fan 230 V/1 phase/50 Hz
G Compressor 220 V/1 phase/50 Hz, fan 220 V/1 phase/50 Hz





Platform GS: Preliminary data

Automatic controls

Unit	Expansion valve type	Orifice		Filter drier type	Sight glass type	Pressure control type	Thermostat type	Solenoid valve type -25°C	Coil code no.	Fan speed controller type	Weatherproof housing code no.
		-10°C	+5°C								
OP-LCHC004	TS 2/TES 2	0X	0X	DML 032	SGN 6	KP 1/KP 7/KP 17	KP 61/EKC 202		018F6701		118U4620
OP-LCHC006	TS 2/TES 2	0X	0X	DML 032	SGN 6	KP 1/KP 7/KP 17	KP 61/EKC 202		018F6701		118U4620
OP-LCHC008	TS 2/TES 2	0X	00	DML 032	SGN 6	KP 1/KP 7/KP 17	KP 61/EKC 202		018F6701		118U4620
OP-LCHC007	TS 2/TES 2	0X	00	DML 032	SGN 6	KP 1/KP 7/KP 17	KP 61/EKC 202		018F6701		118U4620
OP-LCHC010	TS 2/TES 2	0X	00	DML 032	SGN 6	KP 1/KP 7/KP 17	KP 61/EKC 202		018F6701		118U4620
OP-LCHC012	TS 2/TES 2	0X	01	DML 032	SGN 6	KP 1/KP 7/KP 17	KP 61/EKC 202		018F6701		118U4620
OP-LCHC015	TS 2/TES 2	00	01	DML 032	SGN 6	KP 1/KP 7/KP 17	KP 61/EKC 202		018F6701		118U4620
OP-LCHC018	TS 2/TES 2	00	01	DML 032	SGN 6	KP 1/KP 7/KP 17	KP 61/EKC 202		018F6701		118U4620
OP-LCHC021	TS 2/TES 2	00	01	DML 032	SGN 6	KP 1/KP 7/KP 17	KP 61/EKC 202		018F6701		118U4621
OP-LCHC026	TS 2/TES 2	00	01	DML 032	SGN 10	KP 1/KP 7/KP 17	KP 61/EKC 202		018F6701		118U4621
OP-LCHC034	TS 2/TES 2	00	01	DML 032	SGN 10	KP 1/KP 7/KP 17	KP 61/EKC 202		018F6701		118U4621
OP-LCHC048	To be selected depending on your application			DML 053	SGN 10	KP 1/KP 7/KP 17	KP 61/EKC 202	EVR 3	018F6701	RGE-Z1L4-7DS	118U8030
OP-LCHC068		DML 084	SGN 12	KP 1/KP 7/KP 17	KP 61/EKC 202	EVR 3	018F6701	RGE-Z1L4-7DS	118U8031		
OP-LCHC096		DML 084	SGN 12	KP 1/KP 7/KP 17	KP 61/EKC 202	EVR 3	018F6701	RGE-Z1L4-7DS	118U8031		
OP-LCHC108		DML 084	SGN 12	KP 1/KP 7/KP 17	KP 61/EKC 202	EVR 3	018F6701	RGE-Z1L4-7DS	118U8031		
OP-LCHC136		DML 084	SGN 12	KP 1/KP 7/KP 17	KP 61/EKC 202	EVR 6	018F6701	RGE-Z1L4-7DS	118U8032		
OP-LCHC215		DML 165	SGN 16	KP 1/KP 7/KP 17	KP 61/EKC 202	EVR 6	018F6701	RGE-Z1N4-7DS	118U8033		
OP-LCHC271		DML 165	SGN 16	KP 1/KP 7/KP 17	KP 61/EKC 202	EVR 6	018F6701	RGE-Z1N4-7DS	118U8033		
OP-LGHC048		DML 053	SGN 10	KP 1/KP 7/KP 17	KP 61/EKC 202	EVR 3	018F6701	RGE-Z1L4-7DS	7710017		
OP-LGHC068		DML 084	SGN 12	KP 1/KP 7/KP 17	KP 61/EKC 202	EVR 3	018F6701	RGE-Z1L4-7DS	7710018		
OP-LGHC096		DML 084	SGN 12	KP 1/KP 7/KP 17	KP 61/EKC 202	EVR 3	018F6701	RGE-Z1L4-7DS	7710018		
OP-LGHC108		DML 084	SGN 12	KP 1/KP 7/KP 17	KP 61/EKC 202	EVR 3	018F6701	RGE-Z1L4-7DS	7710019		
OP-LGHC136		DML 084	SGN 12	KP 1/KP 7/KP 17	KP 61/EKC 202	EVR 6	018F6701	RGE-Z1L4-7DS	7710019		
OP-LGHC215		DML 165	SGN 16	KP 1/KP 7/KP 17	KP 61/EKC 202	EVR 6	018F6701	RGE-Z1N4-7DS	7710020		
OP-LGHC271		DML 165	SGN 16	KP 1/KP 7/KP 17	KP 61/EKC 202	EVR 6	018F6701	RGE-Z1N4-7DS	7710020		

The mentioned RGE are only suitable for 1 phase fans

OPTYMA™ condensing unit R404A/R507 MBP

Test conditions	Unit	Platform	Version				Electrical code	HP	Condenser coil			Condenser fan	Cooling capacity in [W] at evaporating temperature °C							
			A00	A01	A02	A04			Type	Airflow [m³/h]	Int. volume [dm³]		Fan blade [mm]	-30	-25	-20	-15	-10	-5	
	CECOMAF	OP-MCHC004	TL	114X2208	114X2209		114X2211	G	¼	BG2	231	0.25	1 × 200				265	314	377	
		OP-MCHC006	FR	114X2316	114X2317		114X2319	G	½	BG3	518	0.31	1 × 230				428	511	603	
		OP-MCHC007	NF	114X2424	114X2425		114X2427	G	½	BG4	631	0.40	1 × 254				577	688	810	
		OP-MCHC010	SC	114X2532	114X2533		114X2535	A	½	BG5	583	0.53	1 × 254			604	736	884	1.046	
		OP-MCHC012	SC	114X2540	114X2541		114X2543	G	½	BG5	583	0.53	1 × 254			715	863	1.027	1.205	
		OP-MCHC015	SC	114X2648	114X2649		114X2651	G	½	BG6	1.132	1.1	1 × 300			893	1.081	1.290	1.519	
		OP-MCHC018	SC	114X2756	114X2757		114X2759	G	⅝	BG7	827	1.8	1 × 300			1.062	1.287	1.538	1.816	
		OP-MCHC021	GS	114X2764	114X2765		114X2767	G	⅞	BG7	990	0.84	1 × 300			1.165	1.410	1.665	1.925	
	RGT20	OP-MCHC026	GS	114X2772	114X2773		114X2775	G	1	BG7	990	0.84	1 × 300			1.275	1.575	1.870	2.175	
		OP-MCHC034	GS	114X2880	114X2881		114X2883	G	1½	BG8	2.300	1.36	1 × 350			1.900	2.350	2.800	3.250	
		OP-MCHC038	MP				114X5322		G	1¾	B4	1.750	1.3	1 × 350	1.216	1.582	2.012	2.501	3.045	3.636
							114X5307		D											
							114X5312		E											
		OP-MCHC048	MP				114X5323		G	2	C4	2.150	2.3	1 × 350	1.662	2.187	2.782	3.440	4.149	4.905
							114X5308		D											
							114X5313		E											
		OP-MCHC054	MP				114X5324		G	2½	C4	2.150	2.3	1 × 350	1.763	2.343	2.998	3.715	4.487	5.299
							114X5309		D											
					114X5314		E													
OP-MCHC060	MP				114X5325		G	3	D4	2.000	3.1	1 × 350	2.036	2.675	3.391	4.173	5.010	5.884		
					114X5310		D													
					114X5315		E													
OP-MCHC068	MP				114X5311		D	3½	E4	3.150	2.5	1 × 400	2.388	3.114	3.925	4.809	5.751	6.739		
					114X5316		E													
					114X5029		G													
	SH1 OK	OP-MCZC086	MT				114X5006		D	4½	F4	3.300	3.1	1 × 400	2.231	3.054	4.020	5.119	6.349	7.692
							114X5018		E											
							114X5007		D											
		OP-MCZC096	MT				114X5019		E	4¼	G4	3.150	4.1	1 × 400	2.316	3.222	4.291	5.520	6.900	8.423
							114X5008		D											
							114X5020		E											
		OP-MCZC108	MT				114X5009		D	5½	H4	4.300	4.1	1 × 500	2.914	3.969	5.215	6.653	8.277	10.080
							114X5021		E											
							114X5010		D											
		OP-MCZC121	MT				114X5022		E	6	J4	6.000	4.4	1 × 500	3.362	4.545	5.939	7.552	9.372	11.937
							114X5011		D											
							114X5023		E											
OP-MCZC136	MT				114X5011		D	6½	K4	6.200	4.7	1 × 500	4.048	5.399	6.956	8.715	10.663	12.794		
					114X5012		E													
					114X5023		E													
OP-MCZC171	MT				114X5023		E	8½	L4	5.850	6.3	1 × 500	4.277	5.928	7.843	9.998	12.379	14.950		
					114X5058		D													
					114X5073		E													
	SH1 OK	OP-MGZC215	MT				114X5059		D	10	M4	11.000	7.4	2 × 500	6.040	8.107	10.539	13.348	16.512	20.030
							114X5074		E											
		OP-MGZC242	MT				114X5060		D	12	M4	11.000	7.4	2 × 500	7.180	9.526	12.229	15.268	18.642	22.309
							114X5075		E											
OP-MGZC271	MT				114X5075		E	13½	N4	9.200	12.3	2 × 500	7.989	10.611	13.642	17.070	20.873	25.030		

Test condition EN 13215
 Ambient temperature 32°C
 Suction gas temperature 32°C
 Subcooling within the limits of the condensing unit

Superheat 10K
 32°C

RGT20
 Constant suction gas temp. 32°C
 20°C

CECOMAF
 Household & similar 32°C
 32°C

Version
A00 Without valves and receiver for capillary tubes
A01 With receiver. 2 stop valves. bracket and copper pipes for KP
A02 With receiver, stop valves, universal pressure switch (KP17WB), flexible hoses and electrical box
A04 A01 + KP 17WB + FSA-Kit + power cord (except MCHC034)

Electrical characteristics

Unit	LRA compressor [A]		MCC compressor [A]						MCC Fan [A]	
	400 V/ 3 phase	230 V/ 1 phase	400 V/ 3 phase	Contactor	Overload relay	230 V/ 1 phase	Contactor	Overload relay	400 V/ 3 phase	230 V/ 1 phase
OP-MCHC004	-	7.5	-	-	-	-	-	-	-	0.19
OP-MCHC006	-	10.9	-	-	-	-	-	-	-	0.25
OP-MCHC007	-	20.0	-	-	-	-	-	-	-	0.39
OP-MCHC010	-	18.4	-	-	-	-	-	-	-	0.39
OP-MCHC012	-	23.4	-	-	-	-	-	-	-	0.39
OP-MCHC015	-	23.4	-	-	-	-	-	-	-	0.48
OP-MCHC018	-	23.4	-	-	-	-	-	-	-	0.48
OP-MCHC021	-	24.4	-	-	-	-	-	-	-	0.75
OP-MCHC026	-	26.6	-	-	-	-	-	-	-	0.75
OP-MCHC034	-	27.2	-	-	-	-	-	-	-	0.62
OP-MCHC038	29.2	56	6.3	CI 9	TI 16C	15	CI 16	TI 16C	0.5	1.2
OP-MCHC048	29.2	56	6.3	CI 9	TI 16C	16	CI 16	TI 16C	0.5	1.2
OP-MCHC054	29.2	56	6.4	CI 9	TI 16C	20	CI 20	TI 25C	0.5	1.2
OP-MCHC060	38.1	61	8.5	CI 12	TI 16C	20	CI 20	TI 25C	0.5	1.2
OP-MCHC068	38.1	-	9	CI 12	TI 16C	-	-	-	0.7	1.3
OP-MCZC086	48.5	92	11.5	CI 15	TI 16C	29	-	TI 25C	0.7	1.3
OP-MCZC096	64	-	12	CI 15	TI 16C	-	-	-	0.7	1.3
OP-MCZC108	64	-	14	CI 15	TI 16C	-	-	-	1.2	3.4
OP-MCZC121	80	-	17	CI 20	TI 25C	-	-	-	1.2	3.4
OP-MCZC136	80	-	19	CI 20	TI 25C	-	-	-	1.2	3.4
OP-MCZC171	90	-	22	CI 25	TI 25C	-	-	-	1.2	3.4
OP-MGZC215	105	-	27	CI 37	TI 25C	-	-	-	2x1.2	2x3.4
OP-MGZC242	115	-	30	CI 37	TI 25C	-	-	-	2x1.2	2x3.4
OP-MGZC271	140	-	36	CI 45	TI 25C	-	-	-	2x1.2	2x3.4

				Application range [°C]	Power consumption [W] at evap. temp.		Receiver volume [l]	Dimensions [mm]								Weight [kg]				Compressor
					-10°C	5°C		Fig.	Height H [mm]	Width W [mm]	Length D [mm]	Dist. a [mm]	Dist. b [mm]	Suction line	Liquid line	A00	A01	A02	A04	
0	5	7.2	10																	
450	528	563	588	38°C: -15°C till +10°C	284	0.8	1	226	304	432	310		10 mm	6 mm	12.0	13.8		17.8	TL4DLX	
705	812	860	923	38°C: -15°C till 0°C	502	1.1	2	256	321	444	325		10 mm	6 mm	15.5	17.9		18.9	FR6DLX	
941	1.080	1.143		38°C: -15°C till 0°C	624	1.1	3	296	331	451	325		10 mm	6 mm	15.9	18.3		19.3	NF7MLX	
1.220	1.403	1.486		38°C: -15°C till -5°C	728	1.1	4	296	321	473	325		10 mm	6 mm	19.8	22.0		22.9	SC10MLX	
1.392	1.586			38°C: -15°C till -6.7°C	890	1.1	4	296	321	473	325		10 mm	6 mm	19.8	22.0		22.9	SC12MLX	
1.765	2.026	2.145		38°C: -15°C till -5°C	1.145	1.1	4	350	442	610	370		10 mm	6 mm	33.7	40.6		42.5	SC15MLX	
2.116	2.437	2.584		38°C: -15°C till -5°C	1.235	1.1	4	350	442	610	370		10 mm	6 mm	41.6	43.6		47.4	SC18MLX	
2.195	2.460	2.600		38°C: -25°C till -10°C	1.250	1.6	7	340	430	480	310	385	16 mm	10 mm	33.0	36.0		37.5	GS21MLX	
2.470	2.765	2.850		38°C: -20°C till -10°C	1.500	1.6	7	340	430	480	310	385	16 mm	10 mm	36.0	39.0		40.5	GS26MLX	
3.725	4.200	4.375		38°C: -20°C till -10°C	2.220	2.4	8	450	500	600	310	470	16 mm	10 mm	41.0	44.0		49.5	GS34MLX	
4.270	4.948	6.141	7.660	43°C:-30°C till 0°C 46°C:-25°C till -5°C	1.502		3	5	451	500	600	400	465	5/8"	3/8"			56		MPZ038
5.094	6.520	6.892	7.365		2.016		6	5	555	630	650	400	595	5/8"	1/2"			64		MPZ048
6.146	7.013	7.403	7.900		2.297		6	5	555	630	650	400	595	5/8"	1/2"			65		MPZ054
6.797	7.722	8.137	8.664		2.683		6	5	555	630	650	400	595	5/8"	1/2"			68		MPZ061
7.768	8.813	9.282	9.878		3.081		6	5	605	630	650	400	595	5/8"	1/2"			72		MPZ068
9.146	10.682	11.330	12.301		3.384		8	5	656	755	700	400	720	7/8"	1/2"			95		MTZ51
10.085	11.854	12.604	13.730		3.670		8	5	656	755	700	400	720	7/8"	1/2"			100		MTZ57
12.051	14.187	15.094	16.455		4.888		8	5	656	755	700	400	720	7/8"	1/2"			113		MTZ65
13.601	15.997	17.012	18.534		5.355		10	5	708	900	900	600	865	1 1/8"	1/2"			127		MTZ73
15.106	17.550	18.584	20.136		6.335		10	5	759	900	900	600	865	1 1/8"	1/2"			140		MTZ81
17.700	20.564	21.758	23.549		7.521		14	5	759	900	900	600	865	1 1/8"	5/8"			162		MTZ100
23.863	28.004	29.761	32.395		9.777		14	6	759	1350	820	550	1.315	1 1/8"	5/8"			191		MTZ125
26.266	30.429	32.179	34.805		11.240		14	6	759	1350	820	550	1.315	1 1/8"	5/8"			194		MTZ144
29.508	34.290	36.291	39.292		12.492		14	6	759	1350	820	550	1.315	1 1/8"	5/8"			199		MTZ160

Electrical code

A Compressor 220 V/1 phase/50+60 Hz, fan 220 V/1 phase/50+60 Hz
D Compressor 400 V/3 phase/50 Hz, fan 400 V/3 phase/50 Hz



E Compressor 400 V/3 phase/50 Hz, fan 230 V/1 phase/50 Hz
G Compressor 220 V/1 phase/50 Hz, fan 220 V/1 phase/50 Hz

Platform GS: Preliminary data

Automatic controls

Unit	Expansion valve type	Orifice		Filter drier type	Sight glass type	Pressure control type	Thermostat type	Solenoid valve type		Coil code no.	Fan speed controller type	Weatherproof housing code no.
		-10°C	+5°C					-10°C	+5°C			
OP-MCHC004	TS 2/TES 2	0X	0X	DML 052	SGN 6	KP 1/KP 7/KP 17	KP 61/EKC 202			018F6701		118U4620
OP-MCHC006	TS 2/TES 2	00	00	DML 052	SGN 6	KP 1/KP 7/KP 17	KP 61/EKC 202			018F6701		118U4620
OP-MCHC007	TS 2/TES 2	00	00	DML 052	SGN 6	KP 1/KP 7/KP 17	KP 61/EKC 202			018F6701		118U4620
OP-MCHC010	TS 2/TES 2	01	01	DML 052	SGN 6	KP 1/KP 7/KP 17	KP 61/EKC 202			018F6701		118U4620
OP-MCHC012	TS 2/TES 2	01	01	DML 052	SGN 6	KP 1/KP 7/KP 17	KP 61/EKC 202			018F6701		118U4620
OP-MCHC015	TS 2/TES 2	01	01	DML 052	SGN 6	KP 1/KP 7/KP 17	KP 61/EKC 202			018F6701		118U4621
OP-MCHC018	TS 2/TES 2	01	02	DML 052	SGN 6	KP 1/KP 7/KP 17	KP 61/EKC 202			018F6701		118U4621
OP-MCHC021	TS 2/TES 2	01	02	DML 052	SGN 6	KP 1/KP 7/KP 17	KP 61/EKC 202			018F6701		118U4621
OP-MCHC026	TS 2/TES 2	01	02	DML 052	SGN 10	KP 1/KP 7/KP 17	KP 61/EKC 202			018F6701		118U4621
OP-MCHC034	TS 2/TES 2	01	02	DML 052	SGN 10	KP 1/KP 7/KP 17	KP 61/EKC 202			018F6701		118U4621
OP-MCHC038	To be selected depending on your application			DML053	SGN 10	KP 1/KP 7/KP 17	KP 61/EKC 202	EVR 3		018F6701	RGE-Z1L4-7DS	118U8030
OP-MCHC048				DML084	SGN 12	KP 1/KP 7/KP 17	KP 61/EKC 202	EVR 3		018F6701	RGE-Z1L4-7DS	118U8031
OP-MCHC054				DML084	SGN 12	KP 1/KP 7/KP 17	KP 61/EKC 202	EVR 3		018F6701	RGE-Z1L4-7DS	118U8031
OP-MCHC060				DML084	SGN 12	KP 1/KP 7/KP 17	KP 61/EKC 202	EVR 3		018F6701	RGE-Z1L4-7DS	118U8031
OP-MCHC068				DML084	SGN 12	KP 1/KP 7/KP 17	KP 61/EKC 202	EVR 6		018F6701	RGE-Z1N4-7DS	118U8031
OP-MCZC086				DML 084	SGN 12	KP 1/KP 7/KP 17	KP 61/EKC 202	EVR 6		018F6701	RGE-Z1L4-7DS	118U8032
OP-MCZC096				DML 084	SGN 12	KP 1/KP 7/KP 17	KP 61/EKC 202	EVR 6		018F6701	RGE-Z1L4-7DS	118U8032
OP-MCZC108				DML 084	SGN 12	KP 1/KP 7/KP 17	KP 61/EKC 202	EVR 6		018F6701	RGE-Z1N4-7DS	118U8032
OP-MCZC121				DML 084	SGN 12	KP 1/KP 7/KP 17	KP 61/EKC 202	EVR 6		018F6701	RGE-Z1N4-7DS	118U8033
OP-MCZC136				DML 084	SGN 12	KP 1/KP 7/KP 17	KP 61/EKC 202	EVR 6		018F6701	RGE-Z1N4-7DS	118U8033
OP-MCZC171				DML 165	SGN 16	KP 1/KP 7/KP 17	KP 61/EKC 202	EVR 10		018F6701	RGE-Z1N4-7DS	118U8033
OP-MGZC215				DML 165	SGN 16	KP 1/KP 7/KP 17	KP 61/EKC 202	EVR 10		018F6701	RGE-Z1Q4-7DS	118U8034
OP-MGZC242				DML 165	SGN 16	KP 1/KP 7/KP 17	KP 61/EKC 202	EVR 10		018F6701	RGE-Z1Q4-7DS	118U8034
OP-MGZC271				DML 165	SGN 16	KP 1/KP 7/KP 17	KP 61/EKC 202	EVR 10		018F6701	RGE-Z1Q4-7DS	118U8034

OPTYMA™ condensing unit R404A/R507 MBP –  special designed for areas with high ambient

Test conditions	Unit	Platform	Version A02	Electrical code	HP	Condenser coil			Condenser fan	Cooling capacity in [W] at evaporating temperature °C						
						Type	Airflow [m³/h]	Int. volume [dm³]		Fan blade [mm]	-30	-25	-20	-15	-10	-5
																
RGT20	OP-MGZD030	MT	114X5076	G	1½	C3	1.300	1.7	2 × 254	448	713	1.051	1.460	1.941	2.489	3.098
			114X5046	F												
			114X5061	E												
	OP-MGHD038	MP	114X5341	G	1¾	D3	2.800	1.5	2 × 300	1.253	1.645	2.113	2.651	3.258	3.909	4.612
			114X5326	D												
			114X5331	E												
	OP-MGHD048	MP	114X5342	G	2	E3	2.600	2.2	2 × 300	1.662	2.198	2.810	3.492	4.232	5.052	5.298
			114X5327	D												
			114X5332	E												
	OP-MGHD054	MP	114X5343	G	2½	E3	2.600	2.2	2 × 300	1.781	2.378	3.058	3.808	4.622	5.485	6.392
			114X5328	D												
			114X5333	E												
OP-MGHD060	MP	114X5344	G	3	G3	4.600	2.3	2 × 355	2.117	2.795	3.561	4.423	5.361	6.384	7.477	
		114X5329	D													
		114X5334	E													
OP-MGHD068	MP	114X5330	D	3½	H3	3.600	4.7	2 × 355	2.507	3.301	4.200	5.194	6.269	7.447	8.700	
		114X5335	E													
																
SH10K	OP-MGZD086	MT	114X5081	G	4	H3	3.600	4.7	2 × 355	2.319	3.198	4.240	5.453	6.830	8.364	10.046
			114X5052	D												
			114X5067	E												
	OP-MGZD096	MT	114X5053	D	4¾	H3	3.600	4.7	2 × 355	2.370	3.310	4.422	5.717	7.184	8.824	10.620
			114X5068	E												
																
	OP-MGZD108	MT	114X5054	D	5½	J3	5.400	4.7	2 × 400	3.005	4.113	5.429	6.972	8.740	10.728	12.932
			114X5069	E												
			OP-MGZD121	MT												
	114X5070	E														
	OP-MGZD136	MT			114X5056	D	6½	L3	8.600	5.1	2 × 450	4.198	5.630	7.295	9.207	11.361
			114X5071	E												
			OP-MGZD171	MT	114X5057	D										
	114X5072	E														
	OP-MGZD215	MT			114X5115	D	10	N4	9.200	12.3	2 × 500	6.234	8.384	10.937	13.894	17.266
114X5118			E													
OP-MGZD242			MT	114X5116	D	12										
	114X5119	E														
	OP-MGZD271	MT		114X5117	D		13½	U	14.000	14.3	2 × 600	8.239	10.995	14.199	17.878	22.021
114X5120			E													

Test condition
EN 13215

Ambient temperature
Suction gas temperature
Subcooling within the limits of the condensing unit

Superheat 10K

32°C

RGT20

Constant suction gas temp.
32°C
20°C

Version

- A00** Without valves and receiver for capillary tubes
- A01** With receiver. 2 stop valves. bracket and copper pipes for KP
- A02** With receiver, stop valves, universal pressure switch (KP17WB), flexible hoses and electrical box
- A04** A01 + KP 17WB + FSA-Kit + power cord

Electrical characteristics

Unit	LRA compressor [A]			MCC compressor [A]					MCC fan [A]	
	400 V/ 3 phase	230 V/ 1 phase	400 V/ 3 phase	Contactor	Overload relay	230 V/ 1 phase	Contactor	Overload relay	400 V/ 3 phase	230 V/ 1 phase
OP-MGZD030	20	40	5	CI 6	TI 16C	10	CI 12	TI 16C	-	2x0.32
OP-MGHD038	29.2	56	6.3	CI 9	TI 16C	15	CI 16	TI 16C	2x0.35	2x0.85
OP-MGHD048	29.2	56	6.3	CI 9	TI 16C	16	CI 16	TI 16C	2x0.35	2x0.85
OP-MGHD054	29.2	56	6.4	CI 9	TI 16C	20	CI 20	TI 25C	2x0.35	2x0.85
OP-MGHD060	38.1	61	8.5	CI 12	TI 16C	20	CI 20	TI 25C	2x0.5	2x1.2
OP-MGHD068	38.1	-	9	CI 12	TI 16C	-	-	-	2x0.5	2x1.2
OP-MGZD086	48.5	92	11.5	CI 15	TI 16C	29	CI 30	TI 25C	2x0.5	2x1.2
OP-MGZD096	64	-	12	CI 15	TI 16C	-	-	-	2x0.5	2x1.2
OP-MGZD108	64	-	14	CI 15	TI 16C	-	-	-	2x0.7	2x1.3
OP-MGZD121	80	-	17	CI 20	TI 25C	-	-	-	2x0.7	2x1.3
OP-MGZD136	80	-	19	CI 20	TI 25C	-	-	-	2x1.05	2x1.7
OP-MGZD171	90	-	22	CI 25	TI 25C	-	-	-	2x1.05	2x1.7
OP-MGZD215	105	-	27	CI 37	TI 25C	-	-	-	2x1.2	2x3.4
OP-MGZD242	115	-	30	CI 37	TI 25C	-	-	-	2x1.2	2x3.4
OP-MGZD271	140	-	36	CI 45	TI 25C	-	-	-	2x1.6	2x3.0

temperature

		Application range [°C] at max. ambient temperature	Power consumption [W] at evap. temp.		Receiver volume [l]	Dimensions [mm]								Weight [kg]	Compressor
			-10°C	5°C		Fig.	Height H [mm]	Width W [mm]	Length D [mm]	Dist. a [mm]	Dist. b [mm]	Suction line [inch]	Liquid line [inch]		
5	10														
3.765	4.484	48°C: -30°C till -5°C 46°C: -25°C till 0°C	1.344		3	6	392	700	500	300	660	5/8	5/8	56	MTZ18
5.369	6.226		1.550		6	6	442	800	600	400	760	5/8	5/8	60	MPZ038
6.813	7.733		2.000		6	6	442	800	600	400	760	5/8	5/8	64	MPZ048
7.329	8.374		2.290		6	6	442	800	600	400	760	5/8	1/2	65	MPZ054
8.610	9.790		2.700		8	6	555	1.000	700	460	960	5/8	1/2	88	MPZ061
9.959	11.360		3.050		8	6	555	1.000	700	460	960	5/8	1/2	96	MPZ068
11.869	13.829		3.411		8	6	555	1.000	700	460	960	7/8	1/2	107	MTZ51
12.570	14.645		3.763		8	6	555	1.000	700	460	960	7/8	1/2	109	MTZ57
15.346	17.955		4.427		10	6	555	1.000	700	460	960	7/8	1/2	113	MTZ65
16.355	18.997		4.937		10	6	555	1.000	700	460	960	7/8	1/2	115	MTZ73
19.198	22.250		6.426		10	6	671	1.200	800	500	1.160	1 1/8	1/2	133	MTZ81
22.796	26.436		7.565		14	6	671	1.200	800	500	1.160	1 1/8	5/8	158	MTZ100
29.669	34.509		9.657		14	6	759	1.350	820	550	1.315	1 1/8	5/8	196	MTZ125
32.468	37.337		10.757		14	6	759	1.350	820	550	1.315	1 1/8	5/8	199	MTZ144
37.016	42.813		12.319		14	6	975	1.500	870	500	1.460	1 1/8	5/8	230	MTZ160

Electrical code

A Compressor 220 V/1 phase/50+60 Hz, fan 220 V/1 phase/50+60 Hz
D Compressor 400 V/3 phase/50 Hz, fan 400 V/3 phase/50 Hz

E Compressor 400 V/3 phase/50 Hz, fan 230 V/1 phase/50 Hz
G Compressor 220 V/1 phase/50 Hz, fan 220 V/1 phase/50 Hz

Automatic controls

Unit	Expansion valve type	Orifice		Filter drier type	Sight glass type	Pressure control type	Thermostat type	Solenoid valve type		Coil Code no.	Fan speed controller type	Weatherproof housing code no.
		-10°C	+5°C					-10°C	+5°C			
OP-MGZD030	To be selected depending on your application			DML 053	SGN 10	KP 1/KP 7/KP 17	KP 61/EKC 202	EVR 3	EVR 3	018F6701	RGE-Z1L4-7DS	7710017
OP-MGHD038		DML084	SGN12	KP1/KP7/KP17	KP 61/EKC 202	EVR 3	EVR 3	018F6701	RGE-Z1L4-7DS	118U8036		
OP-MGHD048		DML084	SGN12	KP1/KP7/KP17	KP 61/EKC 202	EVR 3	EVR 6	018F6701	RGE-Z1L4-7DS	118U8036		
OP-MGHD054		DML084	SGN12	KP1/KP7/KP17	KP 61/EKC 202	EVR 3	EVR 6	018F6701	RGE-Z1L4-7DS	118U8036		
OP-MGHD060		DML084	SGN12	KP1/KP7/KP17	KP 61/EKC 202	EVR 3	EVR 6	018F6701	RGE-Z1N4-7DS	118U8037		
OP-MGHD068		DML084	SGN12	KP1/KP7/KP17	KP 61/EKC 202	EVR 6	EVR 6	018F6701	RGE-Z1N4-7DS	118U8037		
OP-MGZD086		DML 084	SGN 12	KP 1/KP 7/KP 17	KP 61/EKC 202	EVR 6	EVR 6	018F6701	RGE-Z1N4-7DS	7710019		
OP-MGZD096		DML 084	SGN 12	KP 1/KP 7/KP 17	KP 61/EKC 202	EVR 6	EVR 10	018F6701	RGE-Z1N4-7DS	7710019		
OP-MGZD108		DML 084	SGN 12	KP 1/KP 7/KP 17	KP 61/EKC 202	EVR 6	EVR 10	018F6701	RGE-Z1N4-7DS	7710019		
OP-MGZD121		DML 084	SGN 12	KP 1/KP 7/KP 17	KP 61/EKC 202	EVR 6	EVR 10	018F6701	RGE-Z1N4-7DS	7710019		
OP-MGZD136		DML 084	SGN 12	KP 1/KP 7/KP 17	KP 61/EKC 202	EVR 6	EVR 10	018F6701	RGE-Z1N4-7DS	7710020		
OP-MGZD171		DML 165	SGN 16	KP 1/KP 7/KP 17	KP 61/EKC 202	EVR 10	EVR 10	018F6701	RGE-Z1N4-7DS	7710020		
OP-MGZD215		DML 165	SGN 16	KP 1/KP 7/KP 17	KP 61/EKC 202	EVR 10	EVR 15	018F6701	RGE-Z1Q4-7DS	118U8034		
OP-MGZD242		DML 165	SGN 16	KP 1/KP 7/KP 17	KP 61/EKC 202	EVR 10	EVR 15	018F6701	RGE-Z1Q4-7DS	118U8034		
OP-MGZD271		DML 165	SGN 16	KP 1/KP 7/KP 17	KP 61/EKC 202	EVR 10	EVR 15	018F6701	RGE-Z1Q4-7DS	7710021		

The mentioned RGE are only suitable for 1 phase fans

OPTYMA™ condensing unit R134a LBP/MBP/HBP

	Test conditions	Unit	Platform	Version			Electrical code	HP	Condenser coil			Condenser fan	Cooling capacity in [W] at evaporating temperature °C						
				A00	A01	A04			Type	Air-flow [m³/h]	Int. volume [dm³]		Fan blade [mm]	-35	-30	-25	-20	-15	-10
	CECOMAF	OP-UCGC003	TL	114X0104	114X0105	114X0107	G	1/12	BG1	243	0.13	172	37	52	69	91	117	147	181
		OP-UCGC004	TL	114X0108	114X0109	114X0111	G	1/10	BG1	243	0.13	172	49	67	89	115	146	182	222
		OP-UCGC005	TL	114X0112	114X0113	114X0115	G	1/8	BG1	243	0.13	172	62	83	108	139	175	217	264
		OP-UCGC006	FR	114X0200	114X0201	114X0203	G	1/6	BG2	231	0.25	200	74	106	142	185	235	294	361
		OP-UCGC007	FR	114X0216	114X0217	114X0219	G	1/5	BG2	231	0.25	200	81	114	154	201	257	321	395
		OP-UCGC008	FR	114X0224	114X0225	114X0227	G	1/5	BG2	231	0.25	200	103	141	186	240	303	376	458
		OP-UCGC010	FR	114X0232	114X0233	114X0235	G	1/5	BG2	231	0.25	200	103	149	197	254	320	396	483
		OP-UCGC011	FR	114X0336	114X0337	114X0339	G	1/4	BG3	518	0.31	230	89	168	246	327	414	510	616
		OP-UCGC012	SC	114X0340	114X0341	114X0343	G	1/3	BG3	518	0.31	230	136	202	285	381	490	610	741
		OP-UCGC015	SC	114X0448	114X0449	114X0451	G	3/8	BG4	631	0.40	254			348	463	591	731	882
	OP-UCGC018	SC	114X0556	114X0557	114X0559	G	1/2	BG5	583	0.53	254			404	531	673	833	1.011	
	OP-UCGC021	SC	114X0564	114X0565	114X0567	G	3/8	BG5	583	0.53	254			474	622	792	981	1.189	
	RGT 20	OP-UCGC026	GS	114X0772	114X0773	114X0775	G	3/4	BG7	990	0.84	300				820	1.040	1.290	1.575
		OP-UCGC034	GS	114X0780	114X0781	114X0783	G	1	BG7	990	0.84	300				990	1.250	1.500	1.800

Test condition EN 13125

Ambient temperature
Suction gas temperature
Subcooling within the limits of the condensing unit

RGT 20

Constant suction gas temperature
32°C
20°C

CECOMAF

Household and similar
32°C
32°C

Version

A00 Without valves and receiver for capillary tubes
A01 With receiver, 2 stop valves, bracket and copper pipes for KP
A02 With receiver, stop valves, universal pressure switch (KP17WB) and flexible hoses
A04 A01 + KP 17WB + FSA-Kit + power cord (except UCGC034)

Electrical characteristics

Unit	LRA compressor	MCC fan
	230 V/1 phase	230 V/1 phase
OP-UCGC003	4.9	0.19
OP-UCGC004	5.1	0.19
OP-UCGC005	5.7	0.19
OP-UCGC006	7.5	0.19
OP-UCGC007	8.1	0.19
OP-UCGC008	8.2	0.19
OP-UCGC010	10	0.19
OP-UCGC011	10	0.25
OP-UCGC012	12.6	0.25
OP-UCGC015	14.8	0.39
OP-UCGC018	18.6	0.39
OP-UCGC021	21.8	0.39
OP-UCGC026	20.2	0.75
OP-UCGC034	25.7	0.75

Automatic controls

Unit	Expansion valve type	Orifice		
		-25°C	-10°C	+5°C
OP-UCGC003	TN 2/TEN 2	0X	0X	0X
OP-UCGC004	TN 2/TEN 2	0X	0X	0X
OP-UCGC005	TN 2/TEN 2	0X	0X	0X
OP-UCGC006	TN 2/TEN 2	0X	0X	0X
OP-UCGC007	TN 2/TEN 2	0X	0X	00
OP-UCGC008	TS 2/TES 2	0X	0X	00
OP-UCGC010	TS 2/TES 2	0X	0X	00
OP-UCGC011	TS 2/TES 2	0X	0X	00
OP-UCGC012	TS 2/TES 2	0X	00	01
OP-UCGC015	TN 2/TEN 2	0X	00	01
OP-UCGC018	TN 2/TEN 2	0X	01	01
OP-UCGC021	TN 2/TEN 2	00	01	02
OP-UCGC026	TN 2/TEN 2	00	01	02
OP-UCGC034	TN 2/TEN 2	00	01	02

					Application range at 43°C	Power consumption [W] at evap. temp.	Receiver volume [l]	Dimensions [mm]							Weight [kg]			Compressor
0	5	7.2	10	15				-25°C	Fig.	Height H [mm]	Width W [mm]	Length D [mm]	Dist. a [mm]	Suction line [mm]	Liquid line [mm]	A00	A01	
220	263	282	309	359	-35°C till +15°C	93	0.8	1	197	289	410	310	6	6	11.4	13.2	14.2	TL3GX
269	320	344	377	439	-35°C till +15°C	110	0.8	1	197	289	410	310	6	6	11.4	13.2	14.2	TL4GX
317	374	401	436	502	-35°C till +5°C	123	0.8	1	197	289	410	310	6	6	11.4	13.2	14.2	TL5GX
437	522	532	617		-35°C till +10°C	145	0.8	2	226	304	432	310	10	6	15.1	13.2	17.8	FR6GX
478	571	615	674		-35°C till +10°C	159	0.8	2	226	304	432	310	10	6	15.1	16.7	17.8	FR7.5GX
550	652	699	762		-35°C till +10°C	181	0.8	2	226	304	432	310	10	6	15.1	16.7	17.8	FR8.5GX
580	688	737	805		-35°C till +5°C	207	0.8	2	226	304	432	310	10	6	15.1	16.7	17.8	FR10GX
737	875				-35°C till +5°C	236	1.1	2	256	321	444	325	10	6	15.2	17.6	18.6	FR11GX
880	1029	1.095	1.185	1.349	-35°C till +5°C	261	1.1	4	256	321	444	325	10	6	15.5	17.9	18.9	SC12GX
1.045	1.220	1.221	1.405	1.603	-35°C till +5°C	323	1.1	4	296	331	451	325	10	6	19.8	22.0	22.9	SC15GX
1.210	1.432	1.538	1.682	1.962	-35°C till +5°C	367	1.1	4	296	331	473	325	10	6	19.8	23.4	24.2	SC18GX
1.414	1.652	1.759	1.902	2.160	-35°C till 0°C	437	1.1	4	296	331	513	365	10	6	21.1	23.4	24.2	SC21GX
1.890	2.230	2.390			-20°C till +7.2°C	(-20°) 660	2.4	7	340	430	480	310	12	10	31.5	34.5	36.0	GS26MFX
2.100	2.450	2.600			-20°C till +7.2°C	(-20°) 700	2.4	7	340	430	480	310	12	10	33.0	36.0	37.5	GS34MFX

Electrical Code

- A Compressor 220 V/1 phase/50+60 Hz, fan 220 V/1 phase/50+60 Hz
- D Compressor 400 V/3 phase/50 Hz, fan 400 V/3 phase/50 Hz
- E Compressor 400 V/3 phase/50 Hz, fan 230 V/1 phase/50 Hz
- G Compressor 220 V/1 phase/50 Hz, fan 220 V/1 phase/50 Hz

Platform GS: Preliminary data

Filter drier type	Sight glass type	Pressure control type	Thermostat type	Solenoid valve type (excl. coil)	Coil code no.	Fan speed controller type	Weatherproof housing code no.
DML 032	SGN 6	KP1/KP7/KP17	KP61/KP62	EVR 2	018F6701	RGE-Z1L4-7DS	118U4620
DML 032	SGN 6	KP1/KP7/KP17	KP61/KP62	EVR 2	018F6701	RGE-Z1L4-7DS	118U4620
DML 032	SGN 6	KP1/KP7/KP17	KP61/KP62	EVR 2	018F6701	RGE-Z1L4-7DS	118U4620
DML 032	SGN 6	KP1/KP7/KP17	KP61/KP62	EVR 2	018F6701	RGE-Z1L4-7DS	118U4620
DML 032	SGN 6	KP1/KP7/KP17	KP61/KP62	EVR 2	018F6701	RGE-Z1L4-7DS	118U4620
DML 032	SGN 6	KP1/KP7/KP17	KP61/KP62	EVR 2	018F6701	RGE-Z1L4-7DS	118U4620
DML 032	SGN 6	KP1/KP7/KP17	KP61/KP62	EVR 2	018F6701	RGE-Z1L4-7DS	118U4620
DML 032	SGN 6	KP1/KP7/KP17	KP61/KP62	EVR 2	018F6701	RGE-Z1L4-7DS	118U4620
DML 052	SGN 6	KP1/KP7/KP17	KP61/KP62	EVR 3-6 mm	018F6701	RGE-Z1L4-7DS	118U4620
DML 052	SGN 6	KP1/KP7/KP17	KP61/KP62	EVR 3-6 mm	018F6701	RGE-Z1L4-7DS	118U4620
DML 052	SGN 6	KP1/KP7/KP17	KP61/KP62	EVR 3-6 mm	018F6701	RGE-Z1L4-7DS	118U4620
DML 052	SGN 6	KP1/KP7/KP17	KP61/KP62	EVR 3-6 mm	018F6701	RGE-Z1L4-7DS	118U4620
DML 053	SGN 10	KP1/KP7/KP17	KP61/KP62	EVR 3-10 mm	018F6701	RGE-Z1L4-7DS	118U4621
DML 053	SGN 10	KP1/KP7/KP17	KP61/KP62	EVR 3-10 mm	018F6701	RGE-Z1L4-7DS	118U4621

OPTYMA™ condensing unit R134a –  special designed for areas with high ambient temperature

	Test conditions	Unit	Platform	Version A02	Electrical code	HP	Condenser coil			Cooling capacity in [W] at evaporating temperature °C					
							Type	Airflow [m³/h]	Int. volume [dm³]	Fan blade [mm]	-15	-10	-5	0	5
	SH10K	OP-MGZD030	MT	114X5076	G	1½	C3	1300	1.7	2 × 254	892	1.249	1.662	2.133	2.655
				114X5046	F										
				114X5061	E										
		OP-MGZD038	MT	114X5077	G	1¾	D3	2800	1.5	2 × 300	1.187	1.636	2.168	2.785	3.487
				114X5047	D										
				114X5062	E										
		OP-MGZD048	MT	114X5078	G	2	E3	2600	2.2	2 × 300	1.493	2.013	2.650	3.412	4.302
				114X5048	D										
				114X5063	E										
		OP-MGZD054	MT	114X5079	G	2½	E3	2600	2.2	2 × 300	1.725	2.330	3.057	3.914	4.898
				114X5049	D										
				114X5064	E										
		OP-MGZD060	MT	114X5080	G	3	G3	4600	2.3	2 × 355	2.389	3.094	3.920	4.871	5.951
				114X5050	D										
				114X5065	E										
		OP-MGZD068	MT	114X5051	D	3½	H3	3600	4.7	2 × 355	2.826	3.658	4.422	5.393	6.483
				114X5066	E										
				114X5081	G										
		OP-MGZD086	MT	114X5052	D	4	H3	3600	4.7	2 × 355	2.955	3.945	5.127	6.513	8.097
				114X5067	E										
114X5053	D														
OP-MGZD096	MT	114X5058	E	4½	H3	3600	4.7	2 × 355	3.534	4.722	6.134	7.773	9.636		
		114X5054	D												
		114X5069	E												
OP-MGZD108	MT	114X5055	D	5½	J3	5400	4.7	2 × 400	3.746	5.025	6.542	8.312	10.336		
		114X5070	E												
		114X5056	D												
OP-MGZD121	MT	114X5071	E	6	J3	5400	4.7	2 × 400	4.424	5.845	7.511	9.424	11.581		
		114X5057	D												
		114X5072	E												
OP-MGZD136	MT	114X5057	D	8½	M3	8200	6.8	2 × 450	5.670	7.593	9.876	12.539	15.583		
		114X5057	D												
		114X5115	D												
OP-MGZD171	MT	114X5118	E	10	N4	9200	12.25	2 × 500	7.337	9.725	12.538	15.806	19.529		
		114X5057	D												
		114X5116	D												
OP-MGZD215	MT	114X5117	D	12	N4	9200	12.25	2 × 500	9.072	11.787	14.937	18.538	22.567		
		114X5119	E												
		114X5117	D												
OP-MGZD242	MT	114X5120	E	13½	U	14000	14.2	2 × 600	10.356	13.447	17.074	21.262	26.005		
		114X5119	D												
		114X5120	E												

Test condition
EN 13215
 Ambient temperature 32°C
 Suction gas temperature
 Subcooling within the limits of the condensing unit

Superheat 10K

Version
 A00 Without valves and receiver for capillary tubes
 A01 With receiver, 2 stop valves, bracket and copper pipes for KP
 A02 With receiver, stop valves, universal pressure switch (KP17WB), flexible hoses and electrical box
 A04 A01 + KP 17WB + FSA-Kit + power cord (except UCGC034)

Electrical characteristics

Unit	LRA Compressor [A]		MCC Compressor [A]						MCC Fan [A]	
	400 V/ 3 phase	230 V/ 1 phase	400 V/ 3 phase	Contactora	Overload relay	230 V/ 1 phase	Contactora	Overload relay	400 V/ 3 phase	230 V/ 1 phase
OP-MGZD030	20	40	5	CI 6	TI 16C	10	CI 12	TI 16C	-	2x0.32
OP-MGZD038	16	41	6	CI 9	TI 16C	15	CI 16	TI 16C	2x0.35	2x0.85
OP-MGZD048	23	55	7.5	CI 9	TI 16C	16	CI 16	TI 16C	2x0.35	2x0.85
OP-MGZD054	25	70	8	CI 9	TI 16C	20	CI 20	TI 25C	2x0.35	2x0.85
OP-MGZD060	30	70	9	CI 12	TI 16C	20	CI 20	TI 25C	2x0.5	2x1.2
OP-MGZD068	38	-	10	CI 12	TI 16C	-	-	-	2x0.5	2x1.2
OP-MGZD086	48.5	92	11.5	CI 15	TI 16C	29	CI 30	TI 25C	2x0.5	2x1.2
OP-MGZD096	64	-	12	CI 15	TI 16C	-	-	-	2x0.5	2x1.2
OP-MGZD108	64	-	14	CI 15	TI 16C	-	-	-	2x0.7	2x1.3
OP-MGZD121	80	-	17	CI 20	TI 25C	-	-	-	2x0.7	2x1.3
OP-MGZD136	80	-	19	CI 20	TI 25C	-	-	-	2x1.05	2x1.7
OP-MGZD171	90	-	22	CI 25	TI 25C	-	-	-	2x1.05	2x1.7
OP-MGZD215	105	-	27	CI 37	TI 25C	-	-	-	2x1.2	2x3.4
OP-MGZD242	115	-	30	CI 37	TI 25C	-	-	-	2x1.2	2x3.4
OP-MGZD271	140	-	36	CI 45	TI 25C	-	-	-	2x1.6	2x3

			Application range at following ambient temperature	Power consumption [W] at evap. temp.		Receiver volume [l]	Dimensions [mm]							Weight [kg]	Compressor	
10	15	20		-10°C	5°C		Fig	Height H [mm]	Width W [mm]	Length D [mm]	Dist a [mm]	Dist b [mm]	Suction line [inch]			Liquid line [inch]
3.229	3.846	4.504	46°C: -15°C till +15°C 48°C: -15°C till +10°C	793		3	6	392	700	500	300	660	½	¾	56	MTZ18
4.270	5.132	6.070		915		6	6	442	800	600	400	760	½	½	60	MTZ22
5.315	6.449	7.696		1101		6	6	442	800	600	400	760	½	½	64	MTZ28
6.007	7.238	8.571		1341		6	6	442	800	600	400	760	¾	½	65	MTZ32
7.154	8.475	9.914		1619		8	6	555	1000	700	460	960	¾	½	88	MTZ36
7.695	9.029	10.478		1735		8	6	555	1000	700	460	960	¾	½	96	MTZ40
9.880	11.944	13.984		2636		8	6	555	1000	700	460	960	7/8	½	107	MTZ51
11.718	14.010	16.840		2378		8	6	555	1000	700	460	960	7/8	½	109	MTZ57
12.606	15.116	17.857		2636		10	6	555	1000	700	460	960	7/8	½	113	MTZ65
13.975	16.594	19.400		2896		10	6	555	1000	700	460	960	7/8	½	115	MTZ73
16.312	19.361	22.682		3907		10	6	671	1200	800	500	1160	1 1/8	½	133	MTZ81
18.995	22.761	26.876		4384		14	6	671	1200	800	500	1160	1 1/8	¾	158	MTZ100
23.700	28.311	33.366		5392		14	6	759	1350	820	550	1315	1 1/8	¾	196	MTZ125
27.005	31.831	36.938		6567		14	6	759	1350	820	550	1315	1 1/8	¾	199	MTZ144
31.278	37.051	43.323		6982		14	6	975	1500	870	500	1460	1 1/8	¾	230	MTZ160

Electrical Code

- A Compressor 220 V/1 phase/50+60 Hz, fan 220 V/1 phase/50+60 Hz
- D Compressor 400 V/3 phase/50 Hz, fan 400 V/3 phase/50 Hz
- E Compressor 400 V/3 phase/50 Hz, fan 230 V/1 phase/50 Hz
- G Compressor 220 V/1 phase/50 Hz, fan 220 V/1 phase/50 Hz
- F Compressor 400 V/3 phase/50 Hz, fan 400 V/1 phase/50 Hz

Automatic controls

Unit	Expansion valve type	Orifice		Filter drier type	Sight glass type	Pressure control type	Thermostat type	Solenoid valve type		Coil code number	Fan Speed controller type	Weatherproof housing type
		-10°C	+5°C					-10°C	+5°C			
OP-MCZC030	To be selected depending on your application			DML053	SGN10	KP1/KP7/KP17	KP 61/EKC202			018F6701	RGE-Z1L4-7DS	118U8030
OP-MCZC038		DML053		SGN10	KP1/KP7/KP17	KP 61/EKC202	EVR3	EVR3	018F6701	RGE-Z1L4-7DS	118U8030	
OP-MCZC048		DML084		SGN12	KP1/KP7/KP17	KP 61/EKC202	EVR3	EVR3	018F6701	RGE-Z1L4-7DS	118U8031	
OP-MCZC054		DML084		SGN12	KP1/KP7/KP17	KP 61/EKC202	EVR3	EVR3	018F6701	RGE-Z1L4-7DS	118U8031	
OP-MCZC060		DML084		SGN12	KP1/KP7/KP17	KP 61/EKC202	EVR3	EVR3	018F6701	RGE-Z1L4-7DS	118U8031	
OP-MCZC068		DML084		SGN12	KP1/KP7/KP17	KP 61/EKC202	EVR3	EVR3	018F6701	RGE-Z1L4-7DS	118U8031	
OP-MCZC086		DML084		SGN12	KP1/KP7/KP17	KP 61/EKC202	EVR3	EVR3	018F6701	RGE-Z1L4-7DS	118U8032	
OP-MCZC096		DML084		SGN12	KP1/KP7/KP17	KP 61/EKC202	EVR3	EVR6	018F6701	RGE-Z1L4-7DS	118U8032	
OP-MCZC108		DML084		SGN12	KP1/KP7/KP17	KP 61/EKC202	EVR3	EVR6	018F6701	RGE-Z1N4-7DS	118U8032	
OP-MCZC121		DML084		SGN12	KP1/KP7/KP17	KP 61/EKC202	EVR3	EVR6	018F6701	REG-Z1N4-7DS	118U8033	
OP-MCZC136		DML084		SGN12	KP1/KP7/KP17	KP 61/EKC202	EVR3	EVR6	018F6701	RGE-Z1N4-7DS	118U8033	
OP-MCZC171		DML165		SGN16	KP1/KP7/KP17	KP 61/EKC202	EVR3	EVR6	018F6701	RGE-Z1N4-7DS	118U8033	
OP-MGZC215		DML165		SGN16	KP1/KP7/KP17	KP 61/EKC202	EVR6	EVR6	018F6701	RGE-Z1Q4-7DS	118U8034	
OP-MGZC242		DML165		SGN16	KP1/KP7/KP17	KP 61/EKC202	EVR6	EVR10	018F6701	RGE-Z1Q4-7DS	118U8034	
OP-MGZC271		DML165		SGN16	KP1/KP7/KP17	KP 61/EKC202	EVR6	EVR10	018F6701	RGE-Z1Q4-7DS	118U8034	

The mentioned RGE are only suitable for 1 phase fans

OPTYMA™ condensing unit R134a

	Test conditions	Unit	Platform	Version A02	Electrical code	HP	Condenser coil			Condenser fan	Cooling capacity in [W] at evaporating temperature °C				
							Type	Airflow [m³/h]	Int. volume [dm³]		Fan blade [mm]	-15	-10	-5	0
	SH10K	OP-MCZC030	MT	114X5024	G	1½	A4	1.200	1.2	1 × 300	867	1.210	1.604	2.045	2.529
				114X5000	D										
				114X5012	E										
		OP-MCZC038	MT	114X5025	G	1¾	B4	1.750	1.3	1 × 350	1.150	1.580	2.085	2.664	3.312
				114X5001	D										
				114X5013	E										
		OP-MCZC048	MT	114X5026	G	2	C4	2.150	2.3	1 × 350	1.477	1.986	2.606	3.344	4.197
				114X5002	D										
				114X5014	E										
		OP-MCZC054	MT	114X5027	G	2½	C4	2.150	2.3	1 × 350	1.700	2.289	2.995	3.818	4.757
				114X5003	D										
				114X5015	E										
		OP-MCZC060	MT	114X5028	G	3	D4	2.000	3.1	1 × 350	2.322	2.994	3.773	4.658	5.646
				114X5004	D										
				114X5016	E										
OP-MCZC068	MT	114X5005	D	3½	E4	3.150	2.5	1 × 400	2.736	3.442	4.244	5.147	6.143		
		114X5017	E												
		114X5029	G												
OP-MCZC086	MT	114X5006	D	4	F4	3.300	3.1	1 × 400	2.833	3.770	4.881	6.159	7.601		
		114X5018	E												
		114X5007	D												
OP-MCZC096	MT	114X5007	D	4½	G4	3.150	4.1	1 × 400	3.174	4.232	5.480	6.913	8.527		
		114X5019	E												
		114X5008	D												
OP-MCZC108	MT	114X5008	D	5½	H4	4.300	4.1	1 × 500	3.637	4.863	6.311	7.976	9.860		
		114X5020	E												
		114X5009	D												
OP-MCZC121	MT	114X5009	D	6	J4	6.000	4.4	1 × 500	4.379	5.777	7.410	9.275	11.372		
		114X5021	E												
		114X5010	D												
OP-MCZC136	MT	114X5010	D	6½	K4	6.200	4.7	1 × 500	5.140	6.700	8.513	10.573	12.876		
		114X5022	E												
		114X5011	D												
OP-MCZC171	MT	114X5011	D	8½	L4	5.850	6.3	1 × 500	5.479	7.309	9.465	11.938	14.722		
		114X5023	E												
		114X5058	D												
OP-MGZC215	MT	114X5058	D	10	M4	11.000	7.4	2 × 500	7.169	9.492	12.213	15.352	18.896		
		114X5073	E												
		114X5059	D												
OP-MGZC242	MT	114X5059	D	12	M4	11.000	7.4	2 × 500	8.849	11.467	14.493	17.907	21.692		
		114X5074	E												
		114X5060	D												
OP-MGZC271	MT	114X5060	D	13½	N4	9.200	12.3	2 × 500	10.113	13.087	16.557	20.506	24.933		
		114X5075	E												

Test condition EN 13215
 Ambient temperature 32°C
 Suction gas temperature
 Subcooling within the limits of the condensing unit

Version
 A00 Without valves and receiver for capillary tubes
 A01 With receiver. 2 stop valves, bracket and copper pipes for KP
 A02 With receiver, stop valves, universal pressure switch (KP17WB), flexible hoses and electrical box
 A04 A01 + KP 17WB + FSA-Kit + power cord (except UCGC034)

Electrical characteristics

Unit	LRA Compressor [A]		MCC Compressor [A]						MCC Fan [A]	
	400 V/ 3 phase	230 V/ 1 phase	400 V/ 3 phase	Contactora	Overload relay	230 V/ 1 phase	Contactora	Overload relay	400 V/ 3 phase	230 V/ 1 phase
OP-MCZC030	20	40	5	CI 6	TI 16C	10	CI 12	TI 16C	0.35	0.85
OP-MCZC038	16	41	6	CI 9	TI 16C	15	CI 16	TI 16C	0.5	1.2
OP-MCZC048	23	55	7.5	CI 9	TI 16C	16	CI 16	TI 16C	0.5	1.2
OP-MCZC054	25	70	8	CI 9	TI 16C	20	CI 20	TI 25C	0.5	1.2
OP-MCZC060	30	70	9	CI 12	TI 16C	20	CI 20	TI 25C	0.5	1.2
OP-MCZC068	38	-	10	CI 12	TI 16C	-	-	-	0.7	1.3
OP-MCZC086	48.5	92	11.5	CI 15	TI 16C	29	CI 30	TI 25C	0.7	1.3
OP-MCZC096	64	-	12	CI 15	TI 16C	-	-	-	0.7	1.3
OP-MCZC108	64	-	14	CI 15	TI 16C	-	-	-	1.2	3.4
OP-MCZC121	80	-	17	CI 20	TI 25C	-	-	-	1.2	3.4
OP-MCZC136	80	-	19	CI 20	TI 25C	-	-	-	1.2	3.4
OP-MCZC171	90	-	22	CI 25	TI 25C	-	-	-	1.2	3.4
OP-MGZC215	105	-	27	CI 37	TI 25C	-	-	-	2 x 1.2	2 x 3.4
OP-MGZC242	115	-	30	CI 37	TI 25C	-	-	-	2 x 1.2	2 x 3.4
OP-MGZC271	140	-	36	CI 45	TI 25C	-	-	-	2 x 1.2	2 x 3.4

			Application range at following ambient temperature	Power consumption [W] at evap. temp.		Receiver volume [l]	Dimensions [mm]								Weight [kg]	Compressor
10	15	20		-10°C	5°C		Fig	Height H [mm]	Width W [mm]	Length D [mm]	Dist a [mm]	Dist b [mm]	Suction line [inch]	Liquid line [inch]		
3.050	3.603	4.177	46°C: -15°C till +10°C 43°C: -15°C till +15°C	736		3	5	402	500	600	400	465	½	¾	54	MTZ18
4.025	4.799	5.620		909		3	5	451	500	600	400	465	½	¾	56	MTZ22
5.162	6.233	7.391		1.092		6	5	555	630	650	400	595	½	½	64	MTZ28
5.803	6.951	8.176		1.333		6	5	555	630	650	400	595	¾	½	65	MTZ32
6.734	7.898	9.134		1.529		6	5	555	630	650	400	595	¾	½	68	MTZ36
7.233	8.412	9.663		1.687		6	5	605	630	650	400	595	¾	½	72	MTZ40
9.197	10.910	12.728		2.109		8	5	656	755	700	400	720	¾	½	95	MTZ51
10.314	12.234	14.277		2.297		8	5	656	755	700	400	720	¾	½	100	MTZ57
11.953	14.220	16.640		3.056		8	5	656	755	700	400	720	¾	½	113	MTZ65
13.679	16.197	18.865		3.304		10	5	708	900	900	600	865	1 ½	½	127	MTZ73
15.419	18.153	21.052		4.100		10	5	759	900	900	600	865	1 ½	½	140	MTZ81
17.810	21.136	24.667		4.224		14	5	759	900	900	600	865	1 ½	¾	162	MTZ100
22.838	27.178	31.833		5.419		14	6	759	1.350	820	550	1.315	1 ½	¾	191	MTZ125
25.825	30.206	34.785		6.624		14	6	759	1.350	820	550	1.315	1 ½	¾	194	MTZ144
29.776	35.038	40.590		7.025		14	6	759	1.350	820	550	1.315	1 ½	¾	199	MTZ160

Electrical Code

- A Compressor 220 V/1phase/50+60 Hz, fan 220 V/1phase/50+60 Hz
- D Compressor 400 V/3phase/50 Hz, fan 400 V/3phase/50 Hz
- E Compressor 400 V/3phase/50 Hz, fan 230 V/1phase/50 Hz
- G Compressor 220 V/1phase/50 Hz, fan 220 V/1phase/50 Hz

Automatic controls

Unit	Expansion valve type	Orifice		Filter drier type	Sight glass type	Pressure control type	Thermostat type	Solenoid valve type		Coil code number	Fan Speed controller type	Weatherproof housing type
		-10°C	+5°C					-10°C	+5°C			
OP-MCZC030	To be selected depending on your application			DML053	SGN10	KP1/KP7/KP17	KP 61/EKC202			018F6701	RGE-Z1L4-7DS	118U8030
OP-MCZC038		DML053		SGN10	KP1/KP7/KP17	KP 61/EKC202	EVR3	EVR3	018F6701	RGE-Z1L4-7DS	118U8030	
OP-MCZC048		DML084		SGN12	KP1/KP7/KP17	KP 61/EKC202	EVR3	EVR3	018F6701	RGE-Z1L4-7DS	118U8031	
OP-MCZC054		DML084		SGN12	KP1/KP7/KP17	KP 61/EKC202	EVR3	EVR3	018F6701	RGE-Z1L4-7DS	118U8031	
OP-MCZC060		DML084		SGN12	KP1/KP7/KP17	KP 61/EKC202	EVR3	EVR3	018F6701	RGE-Z1L4-7DS	118U8031	
OP-MCZC068		DML084		SGN12	KP1/KP7/KP17	KP 61/EKC202	EVR3	EVR3	018F6701	RGE-Z1L4-7DS	118U8031	
OP-MCZC086		DML084		SGN12	KP1/KP7/KP17	KP 61/EKC202	EVR3	EVR3	018F6701	RGE-Z1L4-7DS	118U8032	
OP-MCZC096		DML084		SGN12	KP1/KP7/KP17	KP 61/EKC202	EVR3	EVR6	018F6701	RGE-Z1L4-7DS	118U8032	
OP-MCZC108		DML084		SGN12	KP1/KP7/KP17	KP 61/EKC202	EVR3	EVR6	018F6701	RGE-Z1N4-7DS	118U8032	
OP-MCZC121		DML084		SGN12	KP1/KP7/KP17	KP 61/EKC202	EVR3	EVR6	018F6701	REG-Z1N4-7DS	118U8033	
OP-MCZC136		DML084		SGN12	KP1/KP7/KP17	KP 61/EKC202	EVR3	EVR6	018F6701	RGE-Z1N4-7DS	118U8033	
OP-MCZC171		DML165		SGN16	KP1/KP7/KP17	KP 61/EKC202	EVR3	EVR6	018F6701	RGE-Z1N4-7DS	118U8033	
OP-MGZC215		DML165		SGN16	KP1/KP7/KP17	KP 61/EKC202	EVR6	EVR6	018F6701	RGE-Z1Q4-7DS	118U8034	
OP-MGZC242		DML165		SGN16	KP1/KP7/KP17	KP 61/EKC202	EVR6	EVR10	018F6701	RGE-Z1Q4-7DS	118U8034	
OP-MGZC271		DML165		SGN16	KP1/KP7/KP17	KP 61/EKC202	EVR6	EVR10	018F6701	RGE-Z1Q4-7DS	118U8034	

The mentioned RGE are only suitable for 1 phase fans

OPTYMA™ condensing unit R407C

	Test conditions	Unit	Platform	Version A02	Electrical code	HP	Condenser coil			Condenser fan	Cooling capacity in [W] at evaporating temperature °C					
							Type	Airflow [m³/h]	Int. volume [dm³]		Fan blade [mm]	-15	-10	-5	0	
	SH10K	OP-MCZC030	MT	114X5024	G	1½	A4	1.200	1.2	1 × 300	1.161	1.620	2.134	2.700		
				114X5000	D											
				114X5012	E											
		OP-MCZC038	MT	114X5025	G	1¼	B4	1.750	1.3	1 × 350	1.683	2.249	2.878	3.658		
															114X5001	D
															114X5013	E
		OP-MCZC048	MT	114X5026	G	2	C4	2.150	2.3	1 × 350	2.149	2.925	3.794	4.746		
															114X5002	D
															114X5014	E
		OP-MCZC054	MT	114X5027	G	2½	C4	2.150	2.3	1 × 350	2.596	3.405	4.296	5.266		
															114X5003	D
															114X5015	E
		OP-MCZC060	MT	114X5028	G	3	D4	2.000	3.1	1 × 350	3.104	3.986	4.946	5.986		
															114X5004	D
															114X5016	E
OP-MCZC068	MT	114X5005	D	3½	E4	3.150	2.5	1 × 400	3.631	4.637	5.742	6.943				
													114X5017	E		
													114X5029	G		
OP-MCZC086	MT	114X5006	D	4	F4	3.300	3.1	1 × 400	3.965	5.186	6.549	8.048				
													114X5018	E		
													114X5019	E		
OP-MCZC096	MT	114X5007	D	4½	G4	3.150	4.1	1 × 400	4.366	5.765	7.341	9.089				
													114X5019	E		
													114X5008	D		
OP-MCZC108	MT	114X5020	E	5½	H4	4.300	4.1	1 × 500	5.342	6.891	8.659	10.646				
													114X5009	D		
													114X5021	E		
OP-MCZC121	MT	114X5010	D	6	J4	6.000	4.4	1 × 500	6.068	7.882	9.942	12.250				
													114X5022	E		
													114X5011	D		
OP-MCZC136	MT	114X5023	E	6½	K4	6.200	4.7	1 × 500	6.821	8.863	11.143	13.650				
													114X5011	D		
													114X5023	E		
OP-MCZC171	MT	114X5058	D	8½	L4	5.850	6.3	1 × 500	7.433	9.892	12.645	15.692				
													114X5057	E		
													114X5058	D		
OP-MGZC215	MT	114X5059	D	10	M4	11.000	7.4	2 × 500	11.007	14.191	17.757	21.713				
													114X5073	E		
													114X5059	D		
OP-MGZC242	MT	114X5074	E	12	M4	11.000	7.4	2 × 500	12.089	15.606	19.542	23.895				
													114X5074	E		
													114X5060	D		
OP-MGZC271	MT	114X5075	E	13½	N4	9.200	12.3	2 × 500	14.508	18.346	22.647	27.411				
													114X5075	E		
													114X5075	E		

Test condition Superheat 10K
EN 13215
 Ambient temperature 32°C
 Suction gas temperature
 Subcooling within the limits of the condensing unit

Version
A02 With receiver, stop valves, universal pressure switch (KP17WB), flexible hoses and electrical box

Electrical characteristics

Unit	LRA Compressor [A]		MCC Compressor [A]						MCC Fan [A]	
	400 V/ 3 phase	230 V/ 1 phase	400 V/ 3 phase	Contactora	Overload relay	230 V/ 1 phase	Contactora	Overload relay	400 V/ 3 phase	230 V/ 1 phase
OP-MCZC030	20	40	5	CI 6	TI 16C	10	CI 12	TI 16C	0.35	0.85
OP-MCZC038	16	41	6	CI 9	TI 16C	15	CI 16	TI 16C	0.5	1.2
OP-MCZC048	23	55	7.5	CI 9	TI 16C	16	CI 16	TI 16C	0.5	1.2
OP-MCZC054	25	70	8	CI 9	TI 16C	20	CI 20	TI 25C	0.5	1.2
OP-MCZC060	30	70	9	CI 12	TI 16C	20	CI 20	TI 25C	0.5	1.2
OP-MCZC068	38	-	10	CI 12	TI 16C	-	-	-	0.7	1.3
OP-MCZC086	48.5	92	11.5	CI 15	TI 16C	29	CI 30	TI 25C	0.7	1.3
OP-MCZC096	64	-	12	CI 15	TI 16C	-	-	-	0.7	1.3
OP-MCZC108	64	-	14	CI 15	TI 16C	-	-	-	1.2	3.4
OP-MCZC121	80	-	17	CI 20	TI 25C	-	-	-	1.2	3.4
OP-MCZC136	80	-	19	CI 20	TI 25C	-	-	-	1.2	3.4
OP-MCZC171	90	-	22	CI 25	TI 25C	-	-	-	1.2	3.4
OP-MGZC215	105	-	27	CI 37	TI 25C	-	-	-	2 × 1.2	2 × 3.4
OP-MGZC242	115	-	30	CI 37	TI 25C	-	-	-	2 × 1.2	2 × 3.4
OP-MGZC271	140	-	36	CI 45	TI 25C	-	-	-	2 × 1.2	2 × 3.4

		Application range at following ambient temperature		Power consumption [W] at evap. temp.		Receiver volume [l]	Dimensions [mm]								Weight [kg]	Compressor	
5	10	38°C		-10°C	5°C		Fig	Height H [mm]	Width W [mm]	Length D [mm]	Dist a [mm]	Dist b [mm]	Suction line [inch]	Liquid line [inch]			
3.305	3.945	-10°C till +10°C		1.007		3	5	408	500	600	400	465	½	⅜	54	MTZ18	
4.309	5.093				1.367		3	5	451	500	620	400	465	½	⅜	56	MTZ22
5.781	6.879				1.639		6	5	555	630	650	400	595	½	½	64	MTZ28
6.294	7.376				1.878		6	5	555	630	650	400	595	⅝	½	65	MTZ32
7.070	8.198				2.248		6	5	555	630	650	400	595	⅝	½	68	MTZ36
8.214	9.550				2.662		6	5	605	630	650	400	595	⅝	½	72	MTZ40
9.662	11.380				2.869		8	5	656	755	700	400	720	⅞	½	95	MTZ51
10.981	12.996				3.061		8	5	656	755	700	400	720	⅞	½	100	MTZ57
12.827	15.180				4.047		8	5	656	755	700	400	720	⅞	½	113	MTZ65
14.764	17.469				4.659		10	5	708	900	900	600	865	1⅛	½	127	MTZ73
16.349	19.224				5.387		10	5	759	900	900	600	865	1⅛	½	140	MTZ81
18.969	22.458				6.209		14	5	759	900	900	600	865	1⅛	⅝	162	MTZ100
25.991	30.572				8.375		14	6	759	1.350	820	550	1.315	1⅛	⅝	191	MTZ125
28.625	33.732				9.399		14	6	759	1.350	820	550	1.315	1⅛	⅝	194	MTZ144
32.558	38.075				10.678		14	6	759	1.350	820	550	1.315	1⅛	⅝	199	MTZ160

Electrical Code

- D** Compressor 400 V/3 phase/50 Hz, fan 400 V/3 phase/50 Hz
- E** Compressor 400 V/3 phase/50 Hz, fan 230 V/1 phase/50 Hz
- G** Compressor 220 V/1 phase/50 Hz, fan 220 V/1 phase/50 Hz

Automatic controls

Unit	Expansion valve type	Orifice		Filter drier type	Sight glass type	Pressure control type	Thermostat type	Solenoid valve type		Coil code number	Fan Speed controller type	Weatherproof housing type
		-10°C	+5°C					-10°C	+5°C			
OP-MCZC030	To be selected depending your application			DML053	SGN10	KP1/KP7/KP17	KP 61/EKC 202			018F6701	RGE-Z1L4-7DS	118U8030
OP-MCZC038				DML053	SGN10	KP1/KP7/KP17	KP 61/EKC 202	EVR 3	EVR 3	018F6701	RGE-Z1L4-7DS	118U8030
OP-MCZC048				DML084	SGN12	KP1/KP7/KP17	KP 61/EKC 202	EVR 3	EVR 3	018F6701	RGE-Z1L4-7DS	118U8031
OP-MCZC054				DML084	SGN12	KP1/KP7/KP17	KP 61/EKC 202	EVR 3	EVR 3	018F6701	RGE-Z1L4-7DS	118U8031
OP-MCZC060				DML084	SGN12	KP1/KP7/KP17	KP 61/EKC 202	EVR 3	EVR 3	018F6701	RGE-Z1L4-7DS	118U8031
OP-MCZC068				DML084	SGN12	KP1/KP7/KP17	KP 61/EKC 202	EVR 3	EVR 6	018F6701	RGE-Z1L4-7DS	118U8031
OP-MCZC086				DML084	SGN12	KP1/KP7/KP17	KP 61/EKC 202	EVR 3	EVR 6	018F6701	RGE-Z1L4-7DS	118U8032
OP-MCZC096				DML084	SGN12	KP1/KP7/KP17	KP 61/EKC 202	EVR 3	EVR 6	018F6701	RGE-Z1L4-7DS	118U8032
OP-MCZC108				DML084	SGN12	KP1/KP7/KP17	KP 61/EKC 202	EVR 3	EVR 6	018F6701	RGE-Z1N4-7DS	118U8032
OP-MCZC121				DML084	SGN12	KP1/KP7/KP17	KP 61/EKC 202	EVR 3	EVR 6	018F6701	REG-Z1N4-7DS	118U8033
OP-MCZC136				DML084	SGN12	KP1/KP7/KP17	KP 61/EKC 202	EVR 3	EVR 6	018F6701	RGE-Z1N4-7DS	118U8033
OP-MCZC171				DML165	SGN16	KP1/KP7/KP17	KP 61/EKC 202	EVR 6	EVR 6	018F6701	RGE-Z1N4-7DS	118U8033
OP-MGZC215				DML165	SGN16	KP1/KP7/KP17	KP 61/EKC 202	EVR 6	EVR 10	018F6701	RGE-Z1Q4-7DS	118U8034
OP-MGZC242				DML165	SGN16	KP1/KP7/KP17	KP 61/EKC 202	EVR 6	EVR 10	018F6701	RGE-Z1Q4-7DS	118U8034
OP-MGZC271				DML165	SGN16	KP1/KP7/KP17	KP 61/EKC 202	EVR 6	EVR 10	018F6701	RGE-Z1Q4-7DS	118U8034

The mentioned RGE are only suitable for 1 phase fans

Dimensions

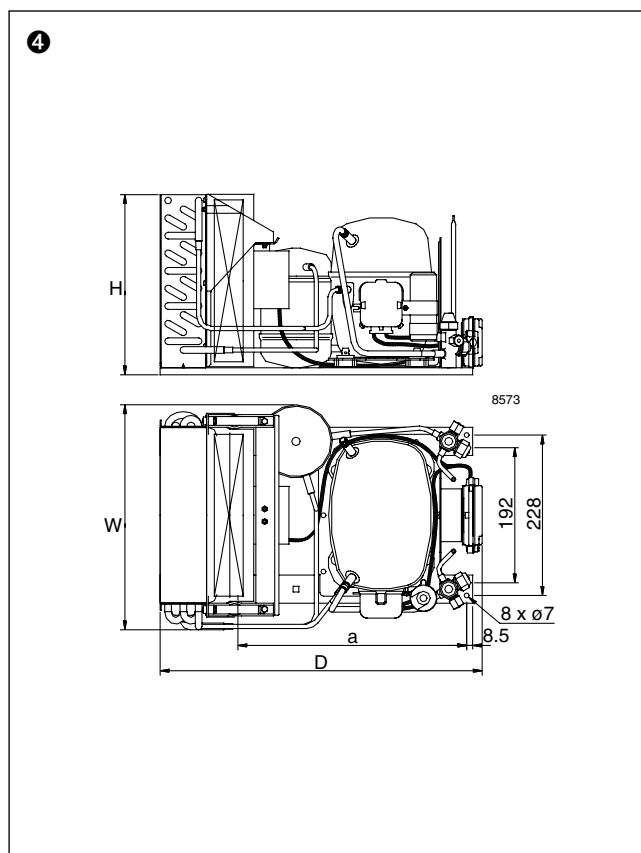
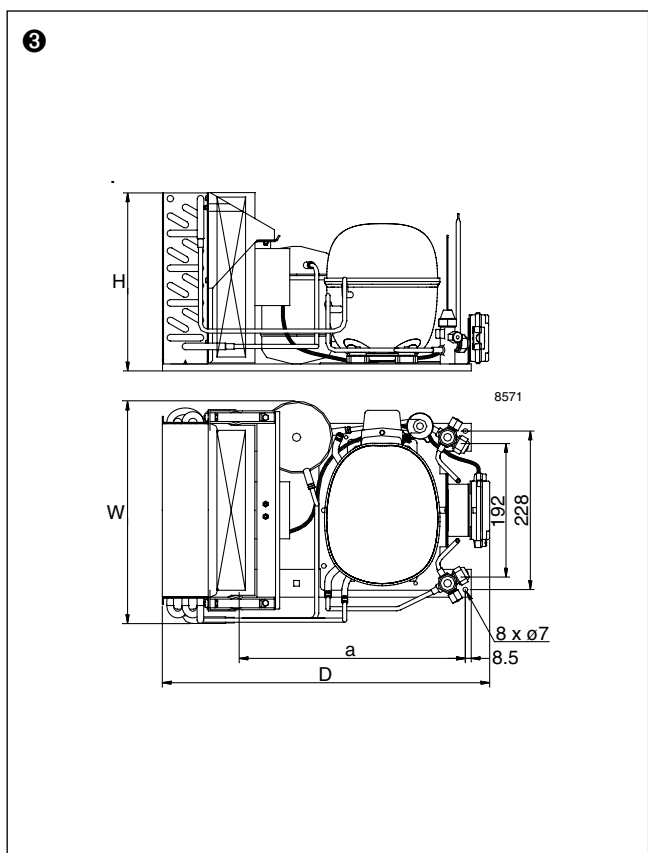
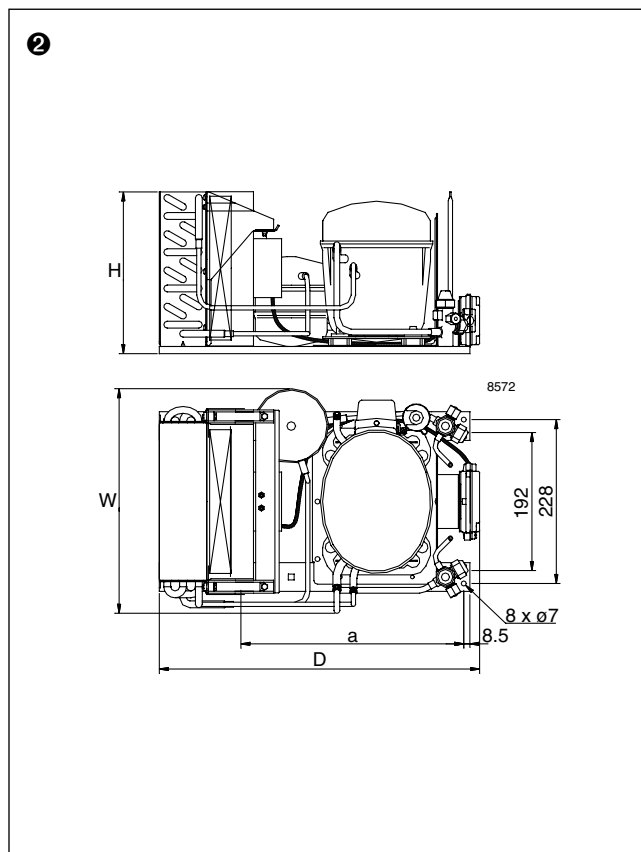
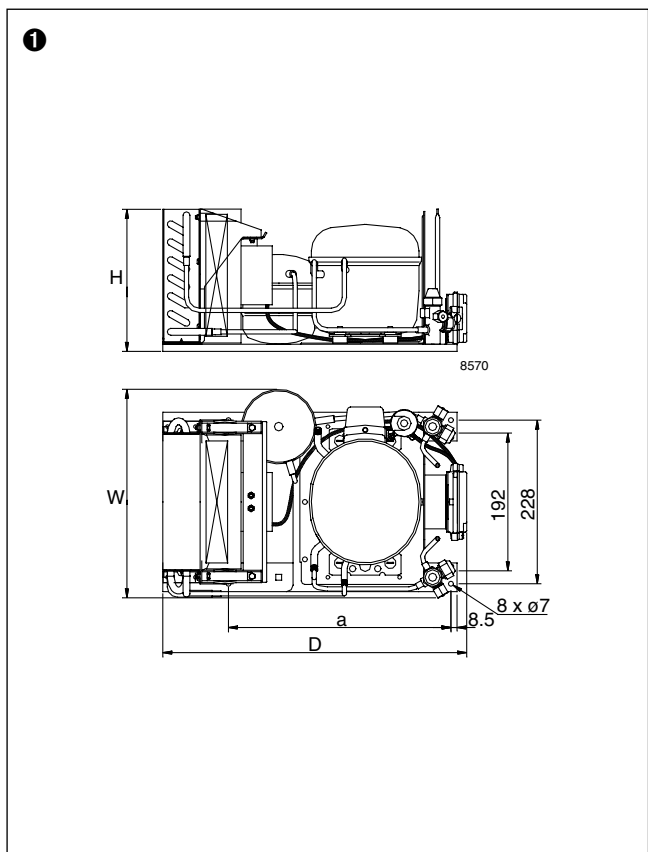

Dimensions

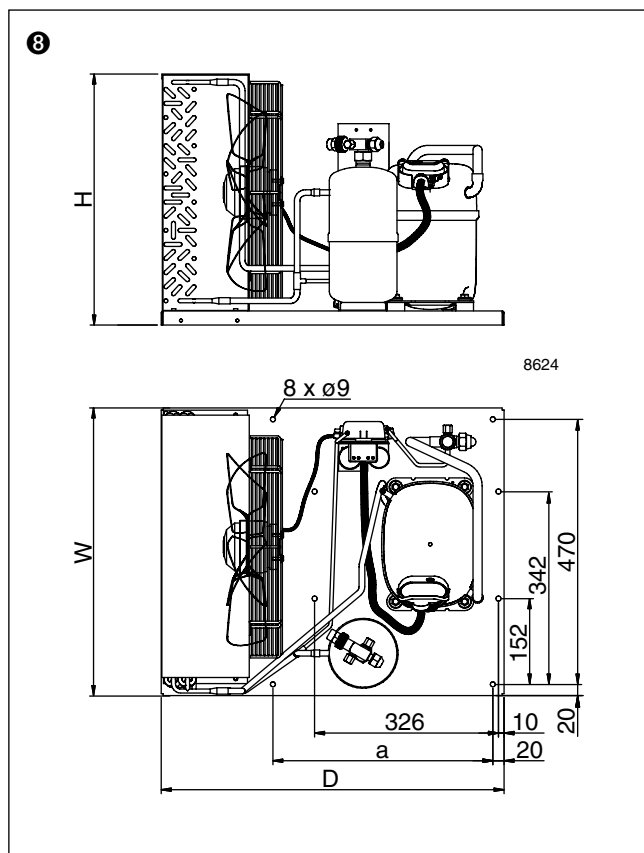
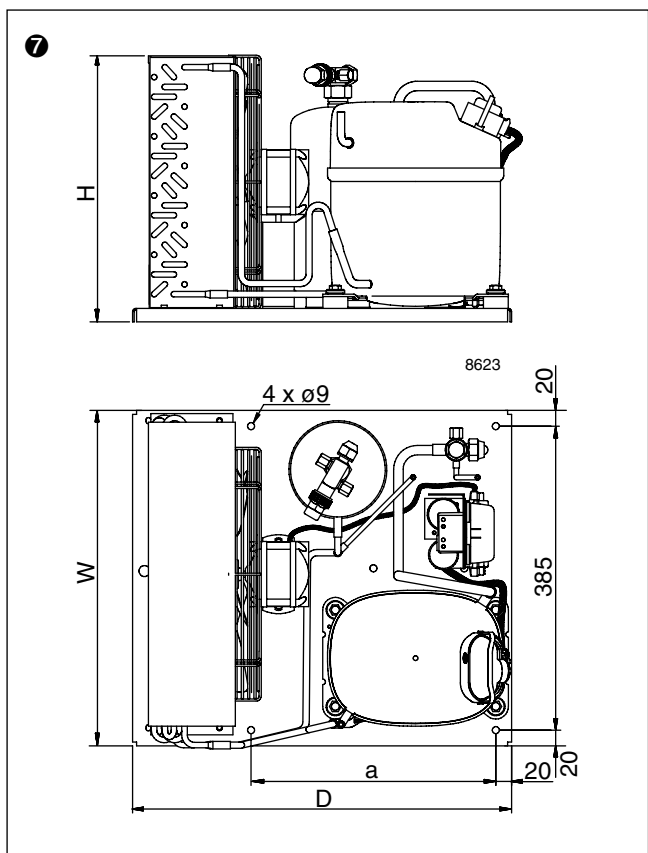
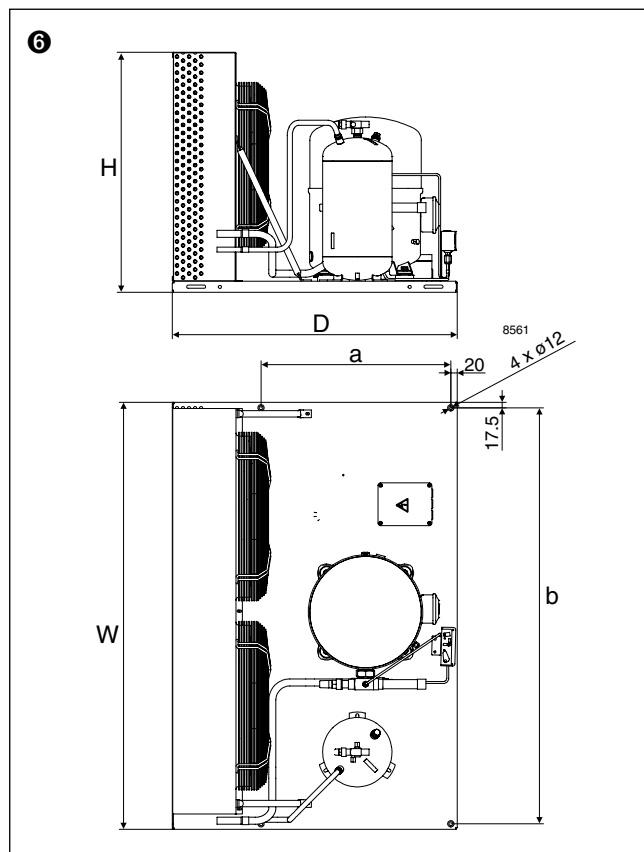
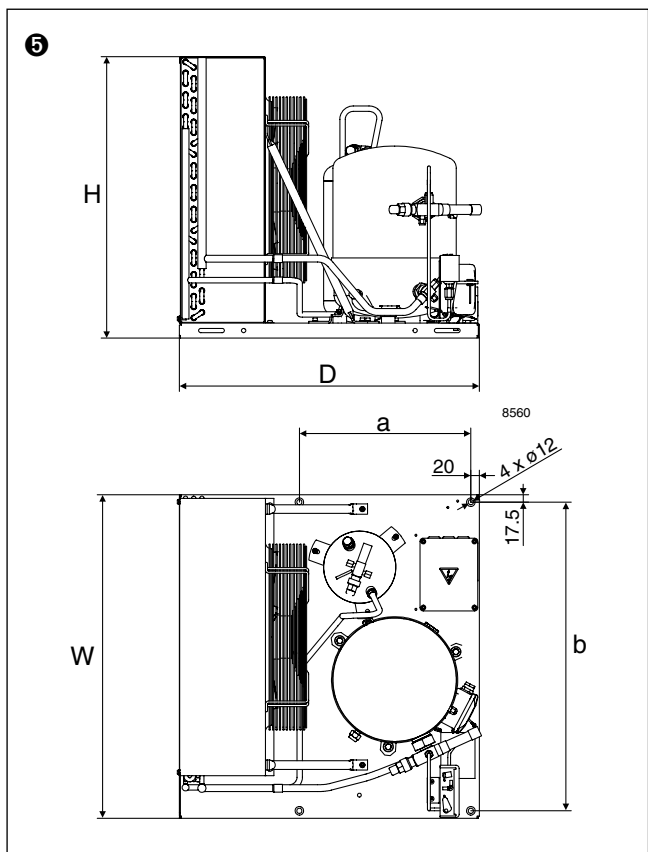



OPTYMA PLUS™

– the low noise condensing units for quick installation

OPTYMA PLUS™ is a unique integral Danfoss condensing unit built around Danfoss components. In designing the range Danfoss combined the very best design knowledge to create a fully factory built condensing unit ready for quick installation and quiet operation.



Product advantages

- Fully weatherproof housing made from epoxy powder coated steel
- Extremely low noise level – as standard supplied with Danfoss compressor, fan speed control, filter drier, shut off valve, pressure switch, magnetic contactor, sight glass and electrical fuse.
- Small dimensions
- Electrical box : IP 54
- Energy efficient
- Low energy consumption

Customer benefits

Installer benefits:

- An integrated Danfoss design
- Easy maintenance: just remove the panels and you have easy access to the components
- Outstanding performance even in the toughest applications
- A minimum size footprint enabling installation in small spaces without compromising the units' performance or service accessibility
- Common Danfoss components all stocked locally by wholesalers

End-user benefits:

- Low noise operation
- Modern practical design with a neutral colour to fit in with its surroundings
- Strong weather resistant housing with lasting durability even in the harshest environments
- Reliable high ambient operation and proven reliability in the most demanding applications
- Energy saving benefits with fan speed control and selection of energy efficient components

OPTYMA PLUS™ R404A/R507 LBP

	Test conditions	Unit	Platform	Code number	Electrical code	HP	Condenser coil			Condenser fan	Ambient °C	Capacity in [W] at evaporating temperature [°C]			
							Type	Airflow [m³/h]	Int. volume [L]	Fan blade [mm]		-45	-40	-35	-30
 SH 10K	SH 10K	OP-LPHC018	SC	114X3108	G	¾	A6	1.500	1.6	1×356	27	276	384	516	671
											32	239	338	459	603
											38	189	280	389	521
											43			331	452
		OP-LPHC026	GS	114X3116	G	1	A6	1.500	1.6	1×356	27	390	550	741	968
											32	328	473	650	859
											38	255	386	545	733
											43			461	632
		OP-LPHC048	NT	114X3224	G	2 ½	C6	3.000	1.1	1×406	27	485	769	1.109	1.503
											32	396	659	971	1.331
											38	290	528	808	1.128
											43		422	675	962
		OP-LPHC048	NT	114X3232	E	2 ½	C6	3.000	1.1	1×406	27	485	769	1.109	1.503
											32	396	659	971	1.331
											38	290	528	808	1.128
											43		422	675	962
		OP-LPHC068	NT	114X3240	G	3 ½	D6	2.600	2.2	1×406	27	969	1.400	1.911	2.503
											32	815	1.212	1.681	2.226
											38	650	1.007	1.428	1.913
											43		852	1.232	1.669
		OP-LPHC068	NT	114X3248	E	3 ½	D6	2.600	2.2	1×406	27	969	1.400	1.911	2.503
											32	815	1.212	1.681	2.226
											38	650	1.007	1.428	1.913
											43		852	1.232	1.669
		OP-LPHC096	NT	114X3356	E	5	F6	6.100	3.4	1×609	27	1223	1.792	2.388	3.227
											32		1.483	2.099	2.872
											38		1.194	1.742	2.432
											43		957	1.445	2.062
OP-LPHC136	NT	114X3364	E	7	F6	6.100	3.4	1×609	27	1.847	2.611	3.550	4.674		
									32		2.275	3.143	4.177		
									38		1.881	2.660	3.586		
									43		1.562	2.266	3.100		
OP-LPHC271	NT	114X3480	E	13 ½	J6	12.200	6.9	2×609	27	3.900	5.530	7.517	9.871		
									32	3.370	4.894	6.736	8.906		
									38	2.721	4.107	5.767	7.711		
									43		3.447	4.946	6.696		

Test condition

EN 13215

Subcooling within the limits of the condensing unit

Superheat 10K

Electrical code

E Compressor 400 V/3 phase/50 Hz, fan 230 V/1 phase/50 Hz

G Compressor 220 V/1 phase/50 Hz, fan 220 V/1 phase/50 Hz

				RGT 20 -35°C EN 13215 (ref. point)	Receiver volume [L]	Dimensions [mm]				Connections		Weight Gross/Net [kg]	Sound power level dB(A)	Sound pressure level 10 m dB(A)	Com- pressor
-25	-20	-15	-10			Housing	Height H	Width W	Depth D	Suction line	Liquid line				
854	1.068	1.312	1.591		1.2	1	652	906	430	½	¾	96/64	61	30	SC18CLX
774	973	1.202	1.463	510											
676	858	1.067	1.307												
594	760														
1.233	1.536	1.879	2.261		1.2	1	652	906	430	¾	¾	102/76	61	30	GS26CLX
1.104	1.385	1.702	2.059	725											
953	1.207	1.495	1.819												
831	1.062														
1.951	2.445	2.981	3.557		4.2	2	760	1.053	480	¾	¾	116/82	72	41	NTZ048
1.738	2.188	2.675	3.198	1.087											
1.487	1.883	2.313	2.774												
1.282	1.634														
1.951	2.445	2.981	3.557		4.2	2	760	1.053	480	¾	¾	116/82	72	41	NTZ048
1.738	2.188	2.675	3.198	1.087											
1.487	1.883	2.313	2.774												
1.282	1.634														
3.177	3.928	4.751	5.640		4.2	2	760	1.053	480	¾	¾	118/84	71	39	NTZ068
2.843	3.534	4.291	5.112	1.884											
2.464	3.082	3.761	4.499												
2.165	2.720														
3.177	3.928	4.751	5.640		4.2	2	760	1.053	480	¾	¾	118/84	71	39	NTZ068
2.843	3.534	4.291	5.112	1.884											
2.464	3.082	3.761	4.499												
2.165	2.720														
4.250	5.469	6.889	8.520		7.1	3	975	1.406	550	¾	¾	161/115	73	42	NTZ096
3.816	4.943	6.261	7.779	2.338											
3.279	4.293	5.486	6.868												
2.824	3.744														
5.988	7.496	9.191	11.068		7.1	3	975	1.406	550	1 ½	½	161/115	73	42	NTZ136
5.387	6.776	8.339	10.073	3.518											
4.668	5.911	7.318	8.881												
4.076	5.197														
12.591	15.685	19.113	22.872		14.0	4	1.794	1.420	650	1 ¾	¾	329/275	78	47	NTZ271
11.411	14.254	17.410	20.869	7.544											
9.949	12.483	15.312	18.416												
8.710	10.986														

EN 13215

Information point RGT 20

Constant Return Gas Temperature 20°C

Ambient temperature = +32°C

Subcooling within the limits of the condensing unit

Sound measurement done in accordance with ISO 3743-1 and ISO 3744.

MBP measured according to EN 13215 @ -10°C suction, +32°C ambient, SH 10 K

LBP measured according to EN 13215 @ -25°C suction, +32°C ambient, SH 10 K

OPTYMA PLUS™ R404A/R507 MBP

	Test conditions	Unit	Platform	Code number	Electrical code	HP	Condenser coil			Condenser fan	Ambient °C	Capacity in [W] at evaporating temperature [°C]			
							Type	Airflow [m³/h]	Int. volume [L]	Fan blade [mm]		-30°C	-25°C	-20°C	-15°C
	SH 10K	OP-MPHC010	SC	114x4100	G	1/3	A6	1.500	1.6	1x356	27			621	776
											32			565	708
											38			496	626
											43				557
		OP-MPHC018	SC	114X4108	G	5/8	A6	1.500	1.6	1x356	27			1.050	1.294
											32			953	1.181
											38			838	1.045
											43				932
		OP-MPZC030	MT	114X4216	G	1 1/2	C6	3.000	1.1	1x406	27	645	971	1.367	1.832
											32	561	860	1.223	1.649
											38	465	734	1.056	1.433
											43	389	632	921	1.258
		OP-MPZC030	MT	114X4224	E	1 1/2	C6	3.000	1.1	1x406	27	645	971	1.367	1.832
											32	561	860	1.223	1.649
											38	465	734	1.056	1.433
											43	389	632	921	1.258
		OP-MPHC034	GS	114X4228	G	1 5/8	A6	1.500	1.6	1x356	27			2.050	2.510
											32			1.872	2.304
											38			2.046	2.492
											43				1.827
OP-MPZC048	MT	114X4232	G	2	D6	2.600	2.2	1x406	27	1.389	1.948	2.604	3.358		
									32	1.175	1.698	2.309	3.008		
									38	934	1.412	1.966	2.600		
									43	746	1.185	1.692	2.269		
OP-MPZC048	MT	114X4240	E	2	D6	2.600	2.2	1x406	27	1.389	1.948	2.604	3.358		
									32	1.175	1.698	2.309	3.008		
									38	934	1.412	1.966	2.600		
									43	746	1.185	1.692	2.269		
OP-MPZC060	MT	114X4248	G	3	D6	2.600	2.2	1x406	27	1.963	2.641	3.426	4.307		
									32	1.727	2.360	3.086	3.898		
									38	1.446	2.025	2.679	3.407		
									43	1.211	1.745	2.341	2.998		
OP-MPZC060	MT	114X4256	E	3	D6	2.600	2.2	1x406	27	1.963	2.641	3.426	4.307		
									32	1.727	2.360	3.086	3.898		
									38	1.446	2.025	2.679	3.407		
									43	1.211	1.745	2.341	2.998		
OP-MPZC086	MT	114X4364	E	4 1/4	F6	6.100	3.4	1x609	27	2.753	3.745	4.937	6.331		
									32	2.401	3.316	4.411	5.691		
									38	2.010	2.830	3.809	4.954		
									43	1.705	2.448	3.330	4.360		
OP-MPZC108	MT	114X4372	E	5 1/4	F6	6.100	3.4	1x609	27	3.441	4.615	6.018	7.656		
									32	3.008	4.102	5.398	6.905		
									38	2.506	3.499	4.667	6.019		
									43	2.102	3.008	4.067	5.290		
OP-MPZC136	MT	114X4380	E	7	G6	5.100	5.2	1x609	27	4.692	6.175	7.897	9.855		
									32	4.153	5.537	7.131	8.942		
									38	3.537	4.796	6.236	7.864		
									43	3.043	4.196	5.505	6.975		
OP-MPZC171	MT	114X4488	E	8 1/2	J6	12.200	6.9	2x609	27	5.238	7.183	9.519	12.246		
									32	4.641	6.464	8.629	11.145		
									38	3.895	5.576	7.542	9.807		
									43	3.243	4.811	6.616	8.679		
OP-MPZC215	MT	114X4496	E	10	J6	12.200	6.9	2x609	27	7.078	9.390	12.129	15.303		
									32	6.221	8.350	10.869	13.785		
									38	5.280	7.183	9.436	12.040		
									43	4.561	6.274	8.295	10.640		

Test condition
EN 13215
Subcooling within the limits of the condensing unit

Superheat 10K

Electrical code

G Compressor 230 V/1 phase/50 Hz, fan 230 V/1 phase/50 Hz
E Compressor 400 V/3 phase/50 Hz, fan 400 V/3 phase/50 Hz

					Receiver volume [L]	Dimensions [mm]				Connections		Weight Gross/Net [kg]	Sound power level dB(A)	Sound pressure level 10 m dB(A)	Compressor
-10°C	-5°C	0°C	5°C	10°C		Housing	Height H	Width W	Depth D	Suction line	Liquid line				
961	1.177	1.425	1.703		1.2	1	652	906	430	¾	¾	96/64	61	30	SC10MLX
879	1.079	1.308	1.566												
780	960	1.167	1.401												
697	861	1.049													
1.580	1.907	2.277	2.691		1.2	1	652	906	430	¾	¾	96/64	61	30	SC18MLX
1.447	1.753	2.100	2.489												
1.287	1.565	1.882	2.240												
1.152	1.406	1.697													
2.365	2.958	3.605	4.299	5.033	4.2	2	760	1.053	480	½	¾	116/83	72	41	MTZ18
2.135	2.677	3.270	3.908	4.585											
1.863	2.346	2.874	3.445	4.053											
1.642	2.073	2.548													
2.365	2.958	3.605	4.299	5.033	4.2	2	760	1.053	480	½	¾	116/83	72	41	MTZ18
2.135	2.677	3.270	3.908	4.585											
1.863	2.346	2.874	3.445	4.053											
1.642	2.073	2.548													
3.035	3.627	4.286	5.012		4.2	2	760	1.053	480	½	¾	114/82	67	36	GS34MLX
2.794	3.345	3.957	4.630												
2.991	3.544	4.152	4.438												
2.234	2.687	3.190	3.742												
4.209	5.149	6.176	7.282	8.459	4.2	2	760	1.053	480	½	¾	120/86	71	39	MTZ28
3.798	4.672	5.625	6.654	7.751											
3.315	4.106	4.972	7.751	6.910											
2.920	3.644	4.436													
4.209	5.149	6.176	7.282	8.459	4.2	2	760	1.053	480	½	¾	120/86	71	39	MTZ28
3.798	4.672	5.625	6.654	7.751											
3.315	4.106	4.972	7.751	6.910											
2.920	3.644	4.436													
5.275	6.318	7.422	8.572	9.755	4.2	2	760	1.053	480	½	¾	125/88	72	40	MTZ36
4.785	5.740	6.749	7.800	8.884											
4.198	5.046	5.942	6.877	7.846											
3.708	4.470	5.272													
5.275	6.318	7.422	8.572	9.755	4.2	2	760	1.053	480	½	¾	125/88	72	40	MTZ36
4.785	5.740	6.749	7.800	8.884											
4.198	5.046	5.942	6.877	7.846											
3.708	4.470	5.272													
7.929	9.718	11.691	13.836	16.138	7.1	3	975	1.406	550	¾	¾	163/117	74	42	MTZ51
7.158	8.814	10.639	12.626	14.767											
6.267	7.753	9.398	11.201	13.146											
5.544	6.884	8.834													
9.517	11.596	13.877	16.339	18.961	7.1	3	975	1.406	550	¾	¾	163/117	74	42	MTZ65
8.626	10.545	12.654	14.937	17.376											
7.565	9.291	11.192	13.262	15.484											
6.686	8.251	9.984													
12.031	14.413	16.977	19.701	22.559	7.1	3	975	1.406	550	1 ½	¾	168/122	76	45	MTZ81
10.951	13.146	15.516	18.037	20.691											
9.667	11.641	13.775	16.054	18.466											
8.610	10.400	12.337													
15.355	18.838	22.650	26.772	31.667	14.0	4	1.794	1.420	650	1 ¾	¾	327/271	78	47	MTZ100
14.003	17.024	20.709	24.499	28.553											
12.371	15.235	18.374	21.782	25.426											
11.000	13.584	16.434													
18.887	22.862	27.204	31.875	36.834	14.0	4	1.794	1.420	650	1 ¾	¾	329/275	78	47	MTZ125
17.095	20.773	24.790	29.126	33.744											
15.010	18.316	21.944	25.878	30.088											
13.322	16.314	19.622													

Sound measurement done in accordance with ISO 3743-1 and ISO 3744.

MBP measured according to EN 13215 @ -10°C suction, +32°C ambient, SH 10 K

LBP measured according to EN 13215 @ -25°C suction, +32°C ambient, SH 10 K

OPTYMA PLUS™ R134a MBP

	Test conditions	Unit	Platform	Code number	Electrical code	HP	Condenser coil			Condenser fan	Ambient °C	Capacity in [W] at evaporating temperature [°C]				
							Type	Airflow [m³/h]	Int. volume [L]	Fan blade [mm]		-15	-10	-5	0	
	SH 10K	OP-MPZC030	MT	114X4216	G	1 ½	C6	3.000	1.1	1×406	27	996	1.425	1.885	2.403	
											32	919	1.285	1.712	2.199	
											38	778	1.119	1.513	1.961	
											43	677	993	1.356	1.768	
		OP-MPZC030	MT	114X4224	E	1 ½	C6	3.000	1.1	1×406	1×406	27	996	1.425	1.885	2.403
												32	919	1.285	1.712	2.199
												38	778	1.119	1.513	1.961
												43	677	993	1.356	1.768
		OP-MPGC034	GS	114X4112	G	1 ⅝	A6	1.500	1.6	1×356	1×356	27	1.347	1.677	2.059	2.493
												32	1.255	1.568	1.930	2.344
												38	1.143	1.436	1.775	2.163
												43	1.048	1.325	1.645	2.011
OP-MPZC048	MT	114X4232	G	2	D6	2.600	2.2	1×406	1×406	27	1.615	2.214	2.974	3.738		
										32	1.518	2.044	2.692	3.469		
										38	1.348	1.835	2.433	3.149		
										43	1.226	1.675	2.225	2.886		
OP-MPZC048	MT	114X4240	E	2	D6	2.600	2.2	1×406	1×406	27	1.615	2.214	2.974	3.738		
										32	1.518	2.044	2.692	3.469		
										38	1.348	1.835	2.433	3.149		
										43	1.226	1.675	2.225	2.886		
OP-MPZC060	MT	114X4248	G	3	D6	2.600	2.2	1×406	1×406	27	2.597	3.278	4.125	5.097		
										32	2.364	3.053	3.858	4.778		
										38	2.138	2.783	3.530	4.385		
										43	1.954	2.558	3.255	4.049		
OP-MPZC060	MT	114X4256	E	3	D6	2.600	2.2	1×406	1×406	27	2.597	3.278	4.125	5.097		
										32	2.364	3.053	3.858	4.778		
										38	2.138	2.783	3.530	4.385		
										43	1.954	2.558	3.255	4.049		
OP-MPZC086	MT	114X4364	E	4 ¼	F6	6.100	3.4	1×609	1×609	27	3.201	4.411	5.908	7.423		
										32	3.021	4.077	5.340	6.822		
										38	2.637	3.612	4.776	6.145		
										43	2.334	3.248	4.335	5.611		
OP-MPZC108	MT	114X4372	E	5 ½	F6	6.100	3.4	1×609	1×609	27	3.662	5.216	6.858	8.792		
										32	3.411	4.754	6.337	8.165		
										38	2.982	4.243	5.723	7.426		
										43	2.632	3.827	5.220	6.822		
OP-MPZC136	MT	114X4380	E	7	G6	5.100	5.2	1×609	1×609	27	5.347	7.201	8.998	11.305		
										32	4.923	6.509	8.386	10.570		
										38	4.402	5.889	7.642	9.677		
										43	3.967	5.370	7.018	8.930		
OP-MPZC171	MT	114X4488	E	8 ½	J6	12.200	6.9	2×609	2×609	27	6.228	8.486	11.253	14.151		
										32	5.900	7.908	10.315	13.150		
										38	5.180	7.066	9.318	11.961		
										43	4.646	6.414	8.521	10.990		
OP-MPZC215	MT	114X4496	E	10	J6	12.200	6.9	2×609	2×609	27	7.987	10.774	13.704	17.156		
										32	7.406	9.805	12.641	15.930		
										38	6.458	8.721	11.382	14.458		
										43	5.721	7.855	10.352	13.234		

Test condition Superheat 10K
EN 13215
 Subcooling within the limits of the condensing unit

Electrical code
G Compressor 230 V/1 phase/50 Hz, fan 230 V/1 phase/50 Hz
E Compressor 400 V/3 phase/50 Hz, fan 400 V/3 phase/50 Hz

				Receiver volume [L]	Housing	Dimensions [mm]			Connections		Weight Gross/Net [kg]	Sound power level dB(A)	Sound pressure level 10 m dB(A)	Compressor
5	10	15	20			Height H	Width W	Depth D	Suction line	Liquid line				
2.987	3.632	4.334	5.087	4.2	2	760	1.053	480	5/8	3/8	116/83	72	41	MTZ18
2.747	3.350	4.006	4.708											
2.462	3.013	3.610	4.249											
2.226	2.732													
2.987	3.632	4.334	5.087	4.2	2	760	1.053	480	5/8	3/8	116/83	72	41	MTZ18
2.747	3.350	4.006	4.708											
2.462	3.013	3.610	4.249											
2.226	2.732													
2.984				1.2	1	652	906	430	1/2	3/8	102/76	63	32	GS34MFX
2.811														
2.603														
2.427														
4.704	5.808	7.048	8.413	4.2	2	760	1.053	480	5/8	3/8	120/86	71	39	MTZ28
4.379	5.419	6.587	7.872											
3.988	4.947	6.023	7.210											
3.660	4.549													
4.704	5.808	7.048	8.413	4.2	2	760	1.053	480	5/8	3/8	120/86	71	39	MTZ28
4.379	5.419	6.587	7.872											
3.988	4.947	6.023	7.210											
3.660	4.549													
6.195	7.410	8.735	10.158	4.2	2	760	1.053	480	3/4	3/8	125/88	72	40	MTZ36
5.814	6.958	8.203	9.540											
5.342	6.398	7.546	8.777											
4.937	5.917													
6.195	7.410	8.735	10.158	4.2	2	760	1.053	480	3/4	3/8	125/88	72	40	MTZ36
5.814	6.958	8.203	9.540											
5.342	6.398	7.546	8.777											
4.937	5.917													
9.242	11.293	13.571	16.072	7.1	3	975	1.406	550	7/8	5/8	163/117	74	42	MTZ51
8.528	10.466	12.621	14.993											
7.723	9.520	11.528	13.747											
7.086	8.770													
10.975	13.406	16.068	18.942	7.1	3	975	1.406	550	7/8	5/8	163/117	74	42	MTZ65
10.235	12.535	15.057	17.783											
9.356	11.501	13.855	16.403											
8.635	10.650													
13.930	16.871	20.108	23.625	7.1	3	975	1.406	550	1 1/8	5/8	168/122	76	45	MTZ81
13.055	15.840	18.909	22.247											
11.993	14.592	17.462	20.588											
11.105	13.546													
17.602	21.539	25.945	30.821	14.0	4	1.794	1.420	650	1 3/8	5/8	327/271	78	47	MTZ100
16.426	20.159	24.338	28.958											
15.015	18.492	22.385	26.685											
13.843	17.097													
21.113	25.554	30.479	35.854	14.0	4	1.794	1.420	650	1 3/8	3/4	329/275	78	47	MTZ125
19.688	23.902	28.568	33.662											
17.965	21.893	26.233	30.972											
16.518	20.194													

Sound measurement done in accordance with ISO 3743-1 and ISO 3744.
MBP measured according to EN 13215 @ -10°C suction, +32°C ambient, SH 10 K
LBP measured according to EN 13215 @ -25°C suction, +32°C ambient, SH 10 K

OPTYMA PLUS™ R407C MBP

	Test conditions	Unit	Platform	Code number	Electrical code	HP	Condenser coil			Condenser fan	Ambient °C	Capacity in [W] at evaporating temperature [°C]		
							Type	Airflow [m³/h]	Int. volume [L]	Fan blade [mm]		-15	-10	-5
	SH 10K	OP-MPZC030	MT	114X4216	G	1 ½	C6	3.000	1.1	1x406	27	1.479	1.999	2.585
											32	1.308	1.798	2.351
											38		1.570	2.083
											43			1.869
		OP-MPZC030	MT	114X4224	E	1 ½	C6	3.000	1.1	1x406	27	1.479	1.999	2.585
											32	1.308	1.798	2.351
											38		1.570	2.083
											43			1.869
		OP-MPZC048	MT	114X4232	G	2	D6	2.600	2.2	1x406	27	2.534	3.402	4.370
											32	2.289	3.112	4.023
											38		2.756	3.603
											43			3.250
OP-MPZC048	MT	114X4240	E	2	D6	2.600	2.2	1x406	27	2.534	3.402	4.370		
									32	2.289	3.112	4.023		
									38		2.756	3.603		
									43			3.250		
OP-MPZC060	MT	114X4248	G	3	D6	2.600	2.2	1x406	27	3.398	4.375	5.452		
									32	3.058	3.986	5.001		
									38		3.508	4.450		
									43			3.983		
OP-MPZC060	MT	114X4256	E	3	D6	2.600	2.2	1x406	27	3.398	4.375	5.452		
									32	3.058	3.986	5.001		
									38		3.508	4.450		
									43			3.983		
OP-MPZC086	MT	114X4364	E	4 ¼	F6	6.100	3.4	1x609	27	5.117	6.471	8.158		
									32	4.544	5.927	7.508		
									38		5.275	6.730		
									43			6.084		
OP-MPZC108	MT	114X4372	E	5 ½	F6	6.100	3.4	1x609	27	6.256	7.978	9.935		
									32	5.701	7.315	9.149		
									38		6.541	8.223		
									43			7.470		
OP-MPZC136	MT	114X4380	E	7	G6	5.100	5.2	1x609	27	7.933	10.125	12.575		
									32	7.271	9.344	11.647		
									38		8.402	10.525		
									43			9.590		
OP-MPZC171	MT	114X4488	E	8 ½	J6	12.200	6.9	2x609	27	9.705	12.536	15.963		
									32	8.627	11.436	14.657		
									38		10.128	13.095		
									43			11.806		
OP-MPZC215	MT	114X4496	E	10	J6	12.200	6.9	2x609	27	12.921	16.388	20.274		
									32	11.790	15.068	18.726		
									38		13.472	16.854		
									43			15.294		

Test condition
EN 13215
 Subcooling within the limits of the condensing unit

Superheat 10K

Electrical code
G Compressor 230 V/1 phase/50 Hz, fan 230 V/1 phase/50 Hz
E Compressor 400 V/3 phase/50 Hz, fan 400 V/3 phase/50 Hz

			Receiver volume [L]	Housing	Dimensions [mm]			Connections		Weight	Sound power level dB(A)	Sound pressure level 10 m dB(A)	Compressor
0	5	10			Height H	Width W	Depth D	Suction line	Liquid line	Gross/Net [kg]			
3.232	3.933	4.678	4.2	2	760	1.053	480	5/8	3/8	116/83	72	41	MTZ18
2.960	3.618	4.318											
2.645	3.252	3.896											
2.393													
3.232	3.933	4.678	4.2	2	760	1.053	480	5/8	3/8	116/83	72	41	MTZ18
2.960	3.618	4.318											
2.645	3.252	3.896											
2.393													
5.425	6.547	7.719	4.2	2	760	1.053	480	5/8	3/8	120/86	71	39	MTZ28
5.009	6.055	7.144											
4.510	5.467	6.459											
4.093													
5.425	6.547	7.719	4.2	2	760	1.053	480	5/8	3/8	120/86	71	39	MTZ28
5.009	6.055	7.144											
4.510	5.467	6.459											
4.093													
6.609	7.828	9.089	4.2	2	760	1.053	480	3/4	3/8	125/88	72	40	MTZ36
6.087	7.227	8.404											
5.453	6.500	7.576											
4.916													
6.609	7.828	9.089	4.2	2	760	1.053	480	3/4	3/8	125/88	72	40	MTZ36
6.087	7.227	8.404											
5.453	6.500	7.576											
4.916													
10.045	12.125	14.376	7.1	3	975	1.406	550	7/8	5/8	163/117	74	42	MTZ51
9.274	11.218	13.325											
8.353	10.135	12.069											
7.590													
12.118	14.506	17.073	7.1	3	975	1.406	550	7/8	5/8	163/117	74	42	MTZ65
11.194	13.433	15.842											
10.098	12.155	14.371											
9.201													
15.249	18.114	21.130	7.1	3	975	1.406	550	1 1/8	5/8	168/122	76	45	MTZ81
14.152	16.827	19.636											
12.824	15.270	17.833											
11.715													
19.809	24.053	28.657	14.0	4	1.794	1.420	650	1 3/8	5/8	327/271	78	47	MTZ100
18.263	22.243	26.562											
16.414	20.071	24.044											
14.885													
24.561	29.198	34.150	14.0	4	1.794	1.420	650	1 3/8	3/4	329/275	78	47	MTZ125
22.747	27.095	31.725											
20.558	24.554	28.806											
18.732													

Sound measurement done in accordance with ISO 3743-1 and ISO 3744.

MBP measured according to EN 13215 @ -10°C suction, +32°C ambient, SH 10 K

LBP measured according to EN 13215 @ -25°C suction, +32°C ambient, SH 10 K

LBP – R404A/R507

Electrical characteristics – 230 V, 1 phase

Unit	LRA Compressor [A]	MCC Compressor [A]	Max. continuous power consumption [kW]	Contactora	Code number	Main switch	Code number	MCC fan [A]	Fan power [W]	
OP-LPHC018	23.5	6	0.97	CI 9	037H0021	CTI25M(B)	047B3149	0.32	1×25	
OP-LPHC026	25.7	5.7	1.37	CI 9						
OP-LPHC048	37	11	2.19	CI 12			037H0031	047B3157	0.63	1×75
OP-LPHC068	53	17	3.30	CI 15						

Electrical characteristics – 400 V, 3 phase

Unit	LRA Compressor [A]	MCC Compressor [A]	Max. continuous power consumption [kW]	Contactora	Code number	Main switch	Code number	MCC fan [A]	Fan power [W]
OP-LPHC048	16	4.8	2.19	CI 6	037H0015	CTI25M(B)	047B3147	0.63	1×75
OP-LPHC068	25	8.4	3.30	CI 9	037H0021		047B3149		
OP-LPHC096	32	10.1	4.21	CI 12	037H0031		047B3157	1.1	1×130
OP-LPHC136	51	14.3	6.37						
OP-LPHC271	96	27	11.99	CI 30	037H0055		047B3159	2×1.1	2×130

Automatic controls

Unit	Filter drier		Sight glass		Pressure switch		Suction valve		Liquid valve		Fan Speed controller	
OP-LPHC018	DML82.5s	023Z4568	SGN10s	014-0182	KP17 WB	060-5397	GBC12s	009G7052	GBC10s	009G7051	RGE-Z1L4-7DS or XGE-4CB1	061H3045 or 061H3142
OP-LPHC026												
OP-LPHC048												
OP-LPHC068												
OP-LPHC096	DML162.5s	023Z4576	SGN12s	014-0183	GBC22s	009G7055	GBC28s	009G7056	GBC12s	009G7052		
OP-LPHC136	DML164s	023Z4580					GBC28s	009G7056	GBC12s	009G7052		
OP-LPHC271	DML166s	023Z4582					SGN19s	014-0185	GBC35s	009G7057	GBC18s	009G7054

Spare parts

Unit	Platform	Receiver volume [L]		Fan Motor (capacitor included)		Fan Blade		Fan Grill		Fan capacitor		Handling handle
OP-LPHC018	SC	1.2	118U0003	Fan motor 25 W	118U0016	Blade Ø14"	118U0017	Grill H1	118U0018	1.8 µF	118U0019	118U0013
OP-LPHC026	GS											
OP-LPHC048	NT	4.2	118U0004	Fan motor 75 W	118U0007	Blade Ø16"	118U0009	Grill H2	118U0011	3.5 µF	118U0014	
OP-LPHC068	NT											
OP-LPHC096	NT	7.1	118U0005	Fan motor 130 W	118U0008	Blade Ø24"	118U0010	Grill H3	118U0012	6.0 µF	118U0015	
OP-LPHC136	NT											
OP-LPHC271	NT							14.0	118U0006	Grill H4		

Note:

LRA (Locked Rotor Amps)

MCC (Maximum Continuous Current)

MBP – R404A/R507

Electrical characteristics – 230 V, 1 phase

Unit	LRA Compressor [A]	MCC Compressor [A]	Max. continuous power consumption [kW]	Contactora	Code number	Main switch	Code number	MCC fan [A]	Fan power [W]
OP-MPHC010	18.4	4.5	0.65	CI 6	037H0015	CTI25M(B)	047B3148	0.32	1×25
OP-MPHC018	23.4	6	1.13	CI 9	037H0021		047B3149		
OP-MPZC030	40	10	1.82	CI 15	037H0049		047B3157	0.63	1×75
OP-MPHC034	45.7	12.6	2.58						
OP-MPZC048	55	16	3.07						
OP-MPZC060	70	20	4.20						

Electrical characteristics – 400 V, 3 phase

Unit	LRA Compressor [A]	MCC Compressor [A]	Max. continuous power consumption [kW]	Contactora	Code number	Main switch	Code number	MCC fan [A]	Fan power [W]
OP-MPZC030	20	5	1.82	CI 6	037H0015	CTI25M(B)	047B3147	0.63	1×75
OP-MPZC048	23	7.5	3.07	CI 9	037H0021		047B3148		
OP-MPZC060	30	8.5	4.20	CI 12	037H0031		047B3157	1.1	1×130
OP-MPZC086	48.5	11.5	4.72						
OP-MPZC108	64	14	6.60						
OP-MPZC136	80	19	8.78						
OP-MPZC171	90	22	9.66	CI 25	037H0051		047B3159	2×1.1	2×130
OP-MPZC215	105	27	13.10	CI 30	037H0055				

Automatic controls

Unit	Filter drier		Sight glass		Pressure switch		Suction valve		Liquid valve		Fan Speed controller			
OP-MPHC010	DML082.5s	023Z4568	SGN10s	014-0182	KP17 WB	060-5397	GBC10s	009G7051	GBC10s	009G7051	RGE-Z1L4-7DS or XGE-4CB1	061H3045 or 061H3142		
OP-MPHC018							GBC16s	009G7053						
OP-MPZC030							GBC18s	009G7054						
OP-MPHC034							GBC22s	009G7055						
OP-MPZC048							GBC28s	009G7056						
OP-MPZC060	DML083s	023Z4570	SGN16s	014-0184	GBC35s	009G7057	GBC18s	009G7054	GBC16s	009G7053				
OP-MPZC086	DML165s	023Z4581					SGN19s	014-0185			GBC18s	009G7054		
OP-MPZC108													GBC16s	009G7053
OP-MPZC136														
OP-MPZC171	DML166s	023Z4582	SGN19s	014-0185	GBC18s	009G7054								
OP-MPZC215							GBC18s	009G7054						

Spare parts

Unit	Receiver volume [L]		Fan Motor (capacitor included)		Fan Blade		Fan Grill		Fan capacitor		Handling handle
OP-MPHC010	1.2	118U0003	Fan motor 25 W	118U0016	Blade Ø14"	118U0017	Grill H1	118U0018	1.8 µF	118U0019	118U0013
OP-MPHC018											
OP-MPZC030	4.2	118U0004	Fan motor 75 W	118U0007	Blade Ø16"	118U0009	Grill H2	118U0011	3.5 µF	118U0014	
OP-MPHC034											
OP-MPZC048											
OP-MPZC060											
OP-MPZC086	7.1	118U0005	Fan motor 130 W	118U0008	Blade Ø24"	118U0010	Grill H3	118U0012	6.0 µF	118U0015	
OP-MPZC108											
OP-MPZC136											
OP-MPZC171	14.0	118U0006	Grill H4								
OP-MPZC215											

MBP – R134a

Electrical characteristics – 230 V, 1 phase

Unit	LRA Compressor [A]	MCC Compressor [A]	Max. continuous power consumption [kW]	Contactora	Code number	Main switch	Code number	MCC fan [A]	Fan power [W]
OP-MPZC030	40	10	1.82	CI 9	037H0021	CTI25MB	047B3149	0.63	1x75
OP-MPGC034	25.7	6.8	1.48					0.32	1x25
OP-MPZC048	55	16	3.07	CI 16	037H0049		047B3157	0.63	1x75
OP-MPZC060	70	20	4.20	CI 20	037H0045		047B3158		

Electrical characteristics – 400 V, 3 phase

Unit	LRA Compressor [A]	MCC Compressor [A]	Max. continuous power consumption [kW]	Contactora	Code number	Main switch	Code number	MCC fan [A]	Fan power [W]
OP-MPZC030	20	5	1.82	CI 6	037H0015	CTI25M	047B3147	0.63	1x75
OP-MPZC048	23	7.5	3.07	CI 9	037H0021		047B3148		
OP-MPZC060	30	8.5	4.20				CI 12	037H0031	047B3157
OP-MPZC086	48.5	11.5	4.72	CI 16	037H0041		047B3158		
OP-MPZC108	64	14	6.60			CI 25	037H0051	CTI25MB	2x1.1
OP-MPZC136	80	19	8.78	CI 30	037H0055			CTI25MB	
OP-MPZC171	90	22	9.66			CI 30	037H0055	CTI25MB	047B3159
OP-MPZC215	105	27	13.10						

Automatic controls

Unit	Filter drier		Sight glass		Pressure switch		Suction valve		Liquid valve		Fan Speed controller	
OP-MPZC030	DML082,5s	023Z4568	SGN10s	014-0182	KP17 WB	060-5397	GBC16s	009G7053	GBC10s	009G7051	RGE-Z1L4-7DS or XGE-4CB1	061H3045 or 061H3142
OP-MPGC034							GBC12s	009G7052				
OP-MPZC048							GBC16s	009G7053				
OP-MPZC060	DML083s	023Z4570	GBC18s	009G7054								
OP-MPZC086	DML165s	023Z4581	SGN16s	014-0184			GBC22s	009G7055	GBC16s	009G7053		
OP-MPZC108							GBC28s	009G7056				
OP-MPZC136							GBC28s	009G7056	GBC18s	009G7054		
OP-MPZC171							GBC35s	009G7057				
OP-MPZC215	DML166s	023Z4582	SGN19s	014-0185								

Spare parts

Unit	Receiver volume [L]		Fan Motor (capacitor included)		Fan Blade		Fan Grill		Fan capacitor		Handling handle
OP-MPZC030	4.2	118U0004	Fan motor 75 W	118U0007	Blade Ø16"	118U0009	Grill H2	118U0011	3.5 µF	118U0014	118U0013
OP-MPGC034	1.2	118U0003	Fan motor 25 W	118U0016	Blade Ø14"	118U0017	Grill H1	118U0018	1.8 µF	118U0018	
OP-MPZC048	4.2	118U0004	Fan motor 75 W	118U0007	Blade Ø16"	118U0009	Grill H2	118U0011	3.5 µF	118U0014	
OP-MPZC060											
OP-MPZC086	7.0	118U0005	Fan motor 130 W	118U0008	Blade Ø24"	118U0010	Grill H3	118U0012	6.0 µF	118U0015	
OP-MPZC108											
OP-MPZC136											
OP-MPZC171	14.0	118U0006					Grill H4				
OP-MPZC215											

Note:

LRA (Locked Rotor Amps)

MCC (Maximum Continuous Current)

MBP – R407C

Electrical characteristics – 230 V, 1 phase

Unit	LRA Compressor [A]	MCC Compressor [A]	Max. continuous power consumption [kW]	Contactora	Code number	Main switch	Code number	MCC fan [A]	Fan power [W]
OP-MPZC030	40	10	1.82	CI 9	037H0021	CTI25MB	047B3149	0.63	1×75
OP-MPZC048	55	16	3.07	CI 16	037H0049		047B3157		
OP-MPZC060	70	20	4.20	CI 20	037H0045		047B3158		

Electrical characteristics – 400 V, 3 phase

Unit	LRA Compressor [A]	MCC Compressor [A]	Max. continuous power consumption [kW]	Contactora	Code number	Main switch	Code number	MCC fan [A]	Fan power [W]
OP-MPZC030	20	5	1.82	CI 6	037H0015	CTI25M	047B3147	0.63	1×75
OP-MPZC048	23	7.5	3.07	CI 9	037H0021		047B3148		
OP-MPZC060	30	8.5	4.20				047B3157		
OP-MPZC086	48.5	11.5	4.72	CI 12	037H0031	CTI25MB	047B3158	1.1	1×130
OP-MPZC108	64	14	6.60	CI 16	037H0041				
OP-MPZC136	80	19	8.78	CI 25	037H0051	CTI25MB	047B3159	2×1.1	2×130
OP-MPZC171	90	22	9.66						
OP-MPZC215	105	27	13.10			CTI25MB			

Automatic controls

Unit	Filter drier		Sight glass		Pressure switch		Suction valve		Liquid valve		Fan Speed controller	
OP-MPZC030	DML082,5s	023Z4568	SGN10s	014-0182	KP17 WB	060-5397	GBC16s	009G7053	GBC10s	009G7051	RGE-Z1L4-7DS or XGE-4CB1	061H3045 or 061H3142
OP-MPZC048							GBC18s	009G7054				
OP-MPZC060	DML083s	023Z4570	SGN16s	014-0184			GBC22s	009G7055	GBC16s	009G7053		
OP-MPZC086	DML165s	023Z4581					GBC28s	009G7056				
OP-MPZC108			GBC35s	009G7057								
OP-MPZC136			GBC18s	009G7054								
OP-MPZC171												
OP-MPZC215	DML166s	023Z4582	SGN19s	014-0185								

Spare parts

Unit	Receiver volume [L]		Fan Motor (capacitor included)		Fan Blade		Fan Grill		Fan capacitor		Handling handle
OP-MPZC030	4.2	118U0004	Fan motor 75 W	118U0007	Blade Ø16"	118U0009	Grill H2	118U0011	3,5 µF	118U0014	118U0013
OP-MPZC048											
OP-MPZC060											
OP-MPZC086	7.0	118U0005	Fan motor 130 W	118U0008	Blade Ø24"	118U0010	Grill H3	118U0012	6.0 µF	118U0015	
OP-MPZC108											
OP-MPZC136											
OP-MPZC171	14.0	118U0006					Grill H4				
OP-MPZC215											

Dimensions

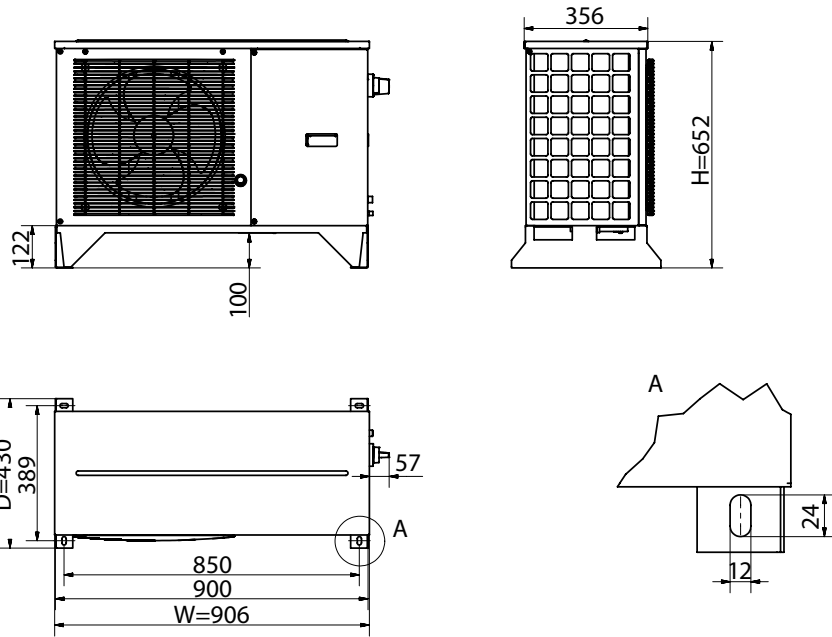

Housing 1

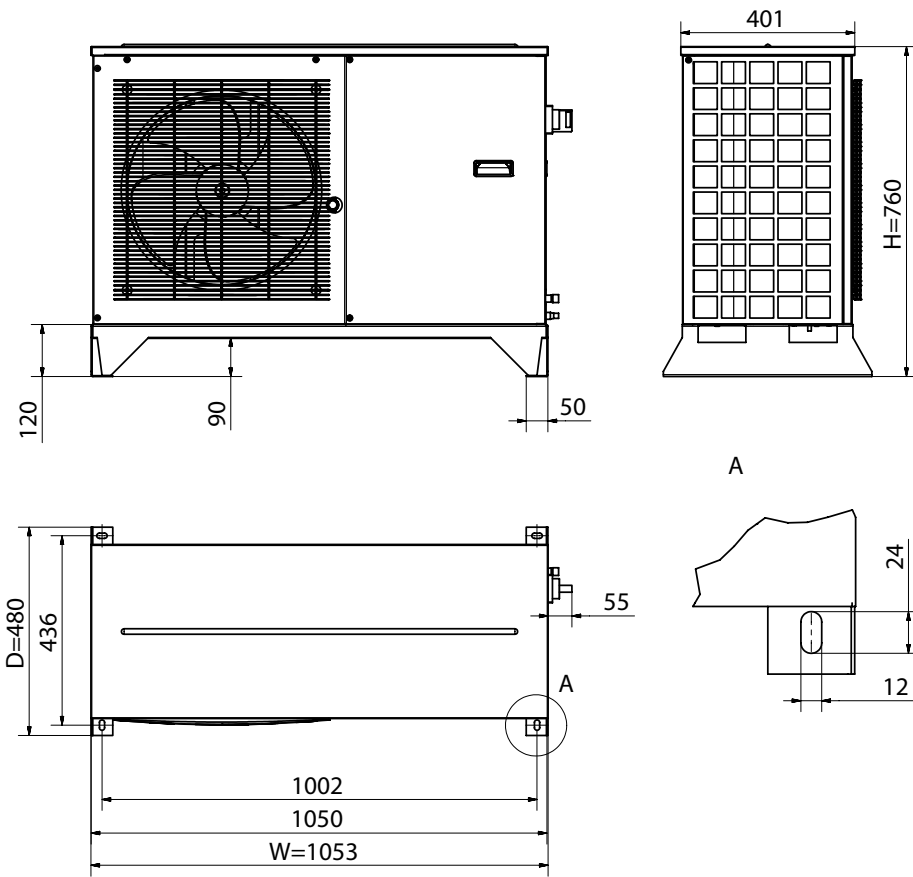

Housing 2

Dimensions

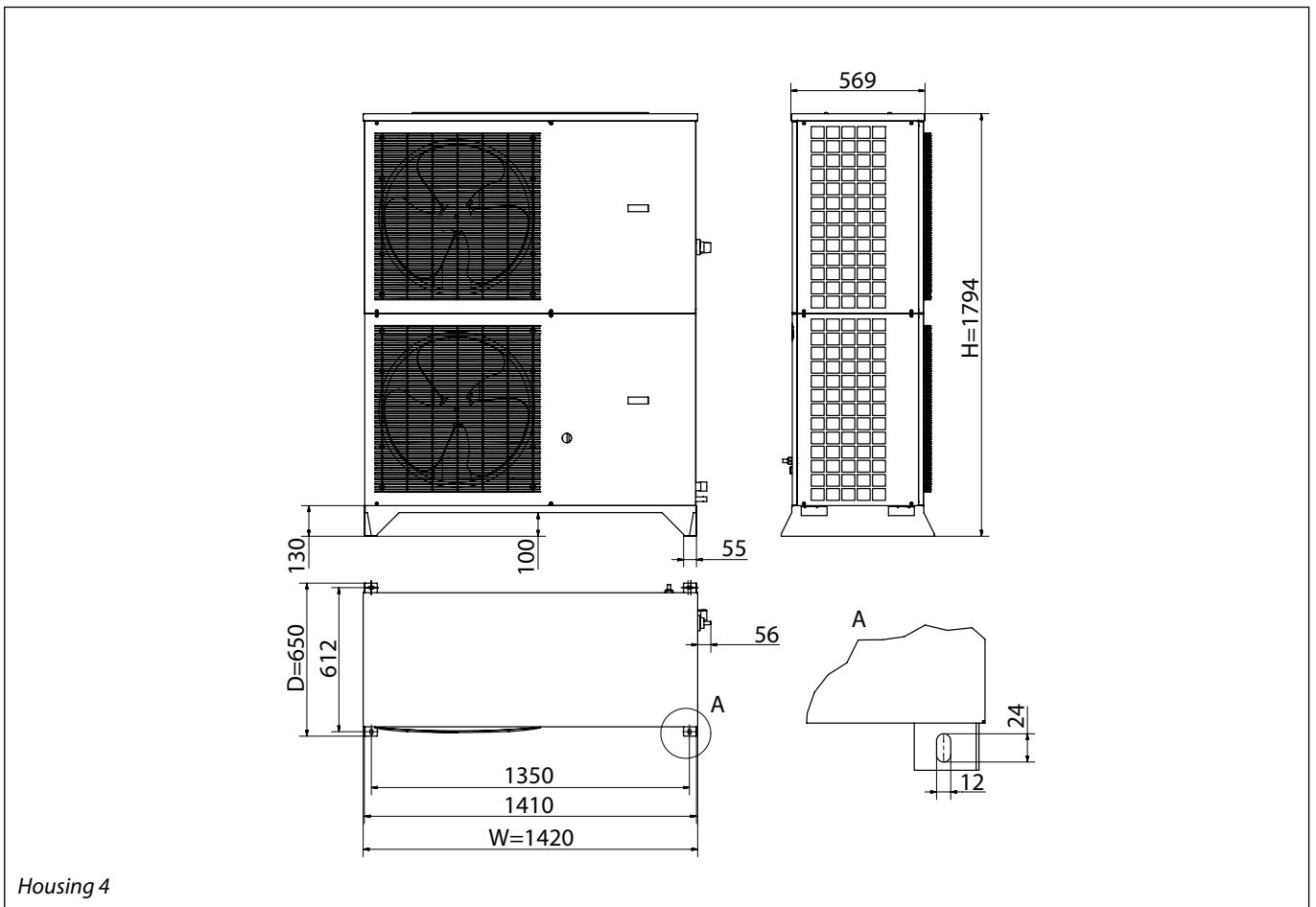
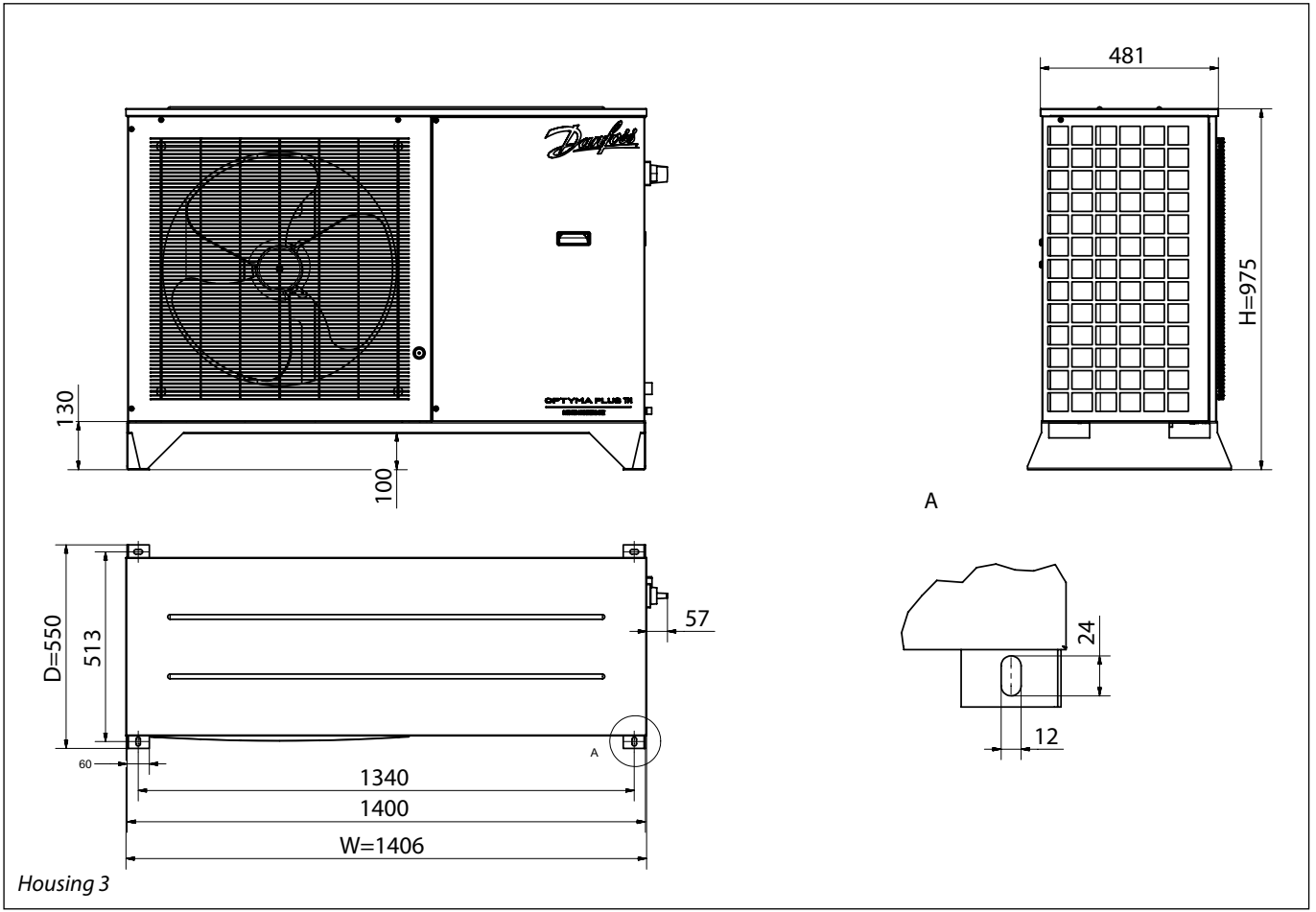

Wiring diagrams

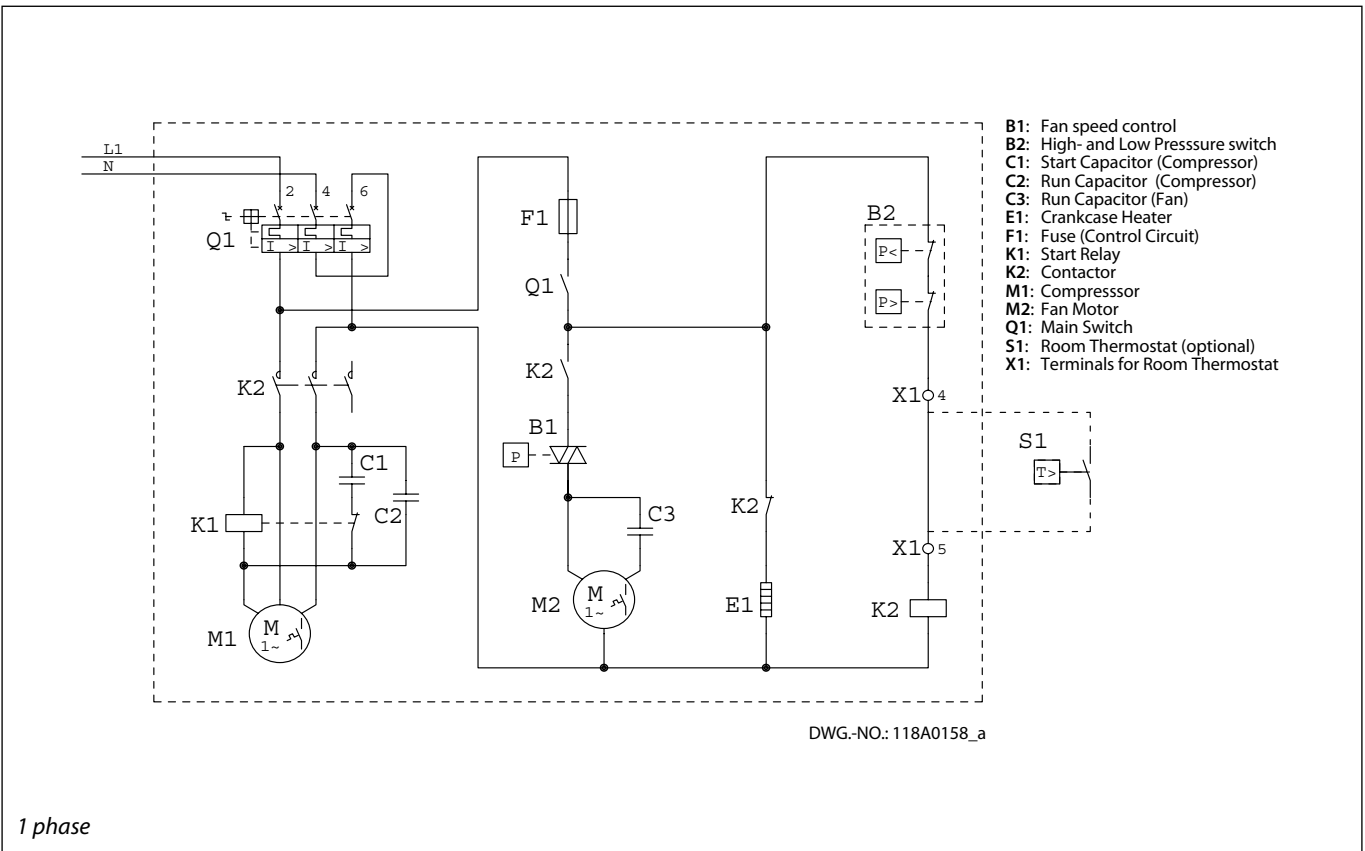
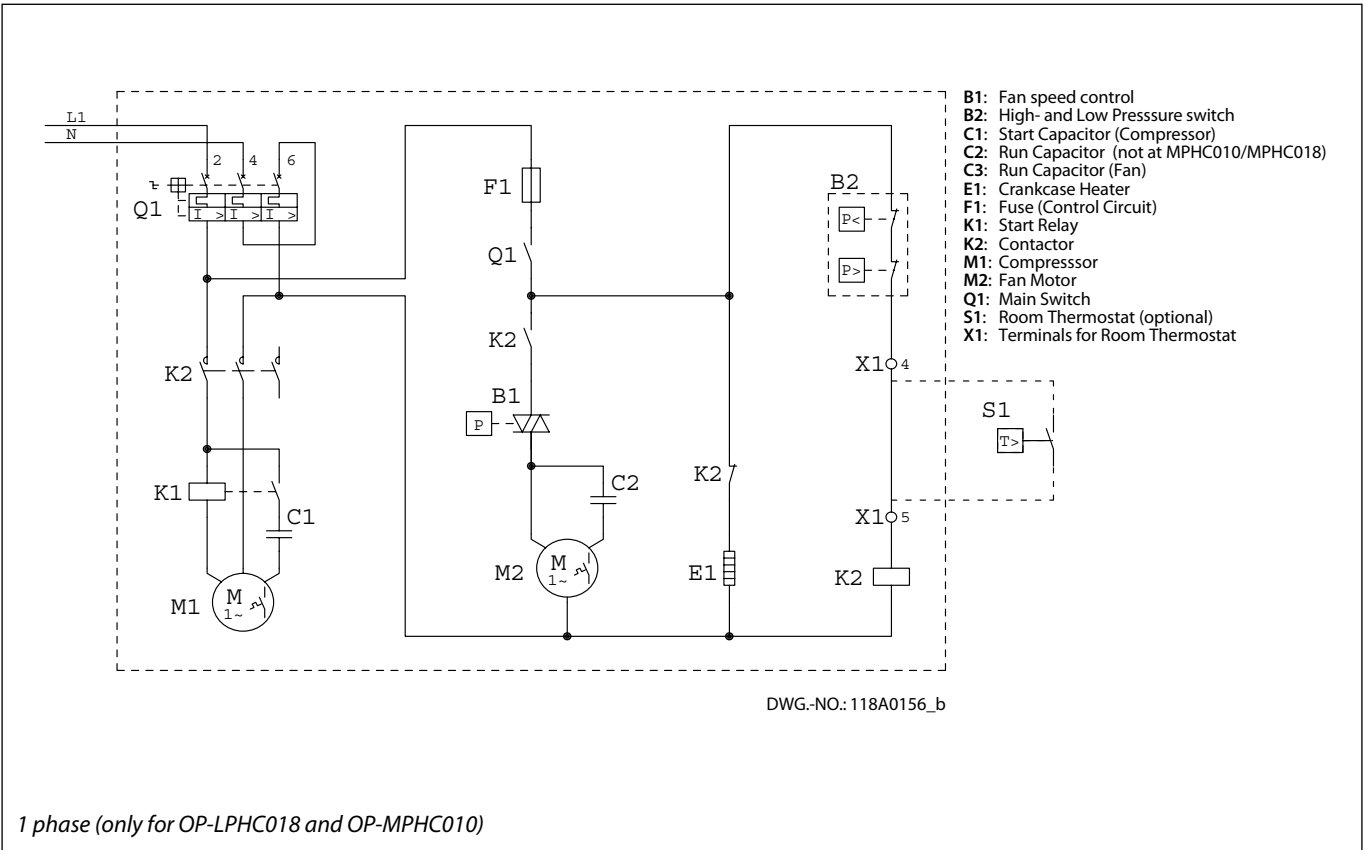

Wiring diagrams

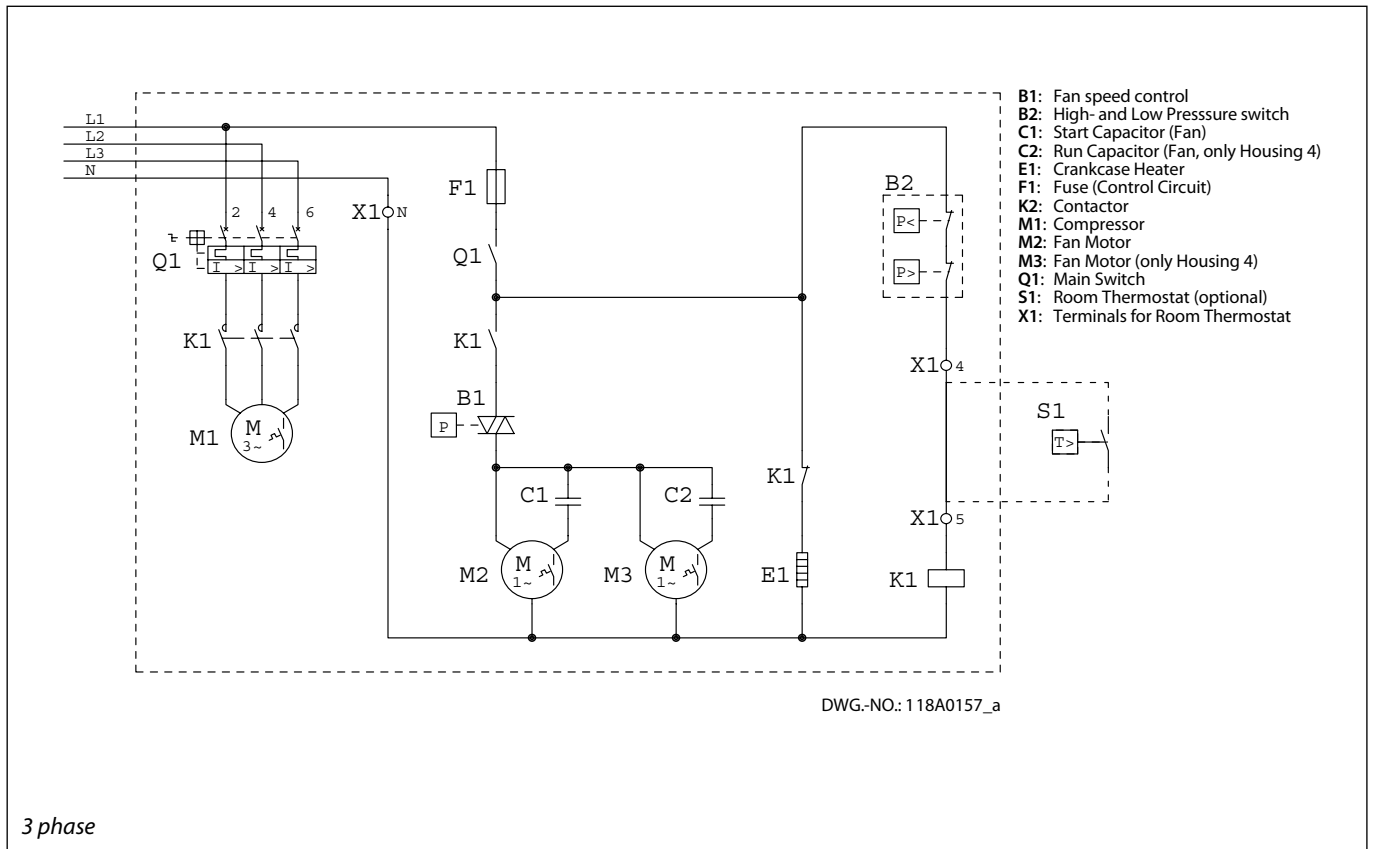

Designation system for the OPTYMA™ PLUS programme

(additional programme frequency etc.: please contact your local wholesaler)

1. Application
2. Design
3. Refrigerant
4. Condenser option
5. Displacement
6. Compressor platform
7. Version
8. Electrical code

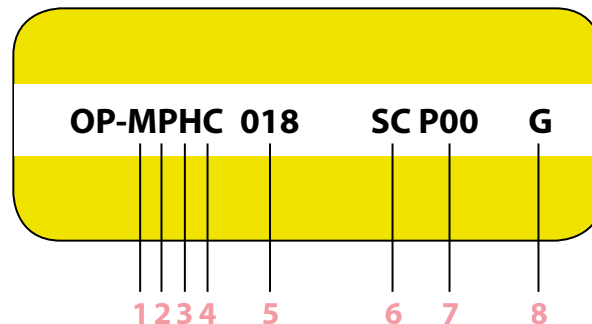

1	L = LBP M = MBP	5	026 = 26 cm ³ 171 = 171 cm ³
2	P = Packaged units	6	GS = GS MT = MTZ NT = NTZ SC = SC
3	Z = R404A, R134a, R507, R407C H = R404A/R507 G = R134a	7	P00
4	C = Standard	8	G = Compressor 220 V/1 phase/50 Hz, fan 230 V/1 phase/50 Hz E = Compressor 400 V/3 phase/50 Hz, fan 230 V/1 phase/50 Hz



Valve factory in Denmark



The Danfoss product range for the refrigeration and air conditioning industry

Danfoss Refrigeration & Air Conditioning is a worldwide manufacturer with a leading position in industrial, commercial and supermarket refrigeration as well as air conditioning and climate solutions.

We focus on our core business of making quality products, components and systems that enhance performance and reduce total life cycle costs – the key to major savings.



Controls for Commercial Refrigeration



Controls for Industrial Refrigeration



Electronic Controls & Sensors



Industrial Automation



Household Compressors



Commercial Compressors



Sub-Assemblies



Thermostats



Brazen plate heat exchangers

We offer a single source for one of the widest ranges of innovative refrigeration and air conditioning components and systems in the world. And, we back technical solutions with business solutions to help your company reduce costs, streamline processes and achieve your business goals.

Danfoss A/S · www.danfoss.com